

WOODWORKERS' TOOLS AND MACHINES

CATALOGUE NO 25

BRONZE MEDAL
1884.

Awards for
Excellence



of Machines
& Tools

GOLD MEDAL
1890.

ESTABLISHED 1828

RICHARD MELHUISH LTD

Tool and Machine Merchants

FETTER LANE, HOLBORN CIRCUS
LONDON, E.C.4

18. JAN 1927

Paid 1/6 Hy

NOTICE Carnott.

The amount charged for this Catalogue will be refunded on receipt of the first Order amounting to 10/- or upwards.

Please attach this Slip to your Order.

R. M., Ltd.

Catalogue No. 25.

ALTERATIONS IN PRICES.

PAGE.	No.	Description	Price
17	No. 200w	Plough Fence for Simple Pattern, 2/6.	
18	No. 208w	1/7 1/9 2/-	
	No. 210w	10d. 11d. 1/- 1/1 1/2	
	No. 211w	No. 13 to 18, 3/- pair.	
20	No. 243w	Cancelled.	
28	No. 332w	Rule is not bevel edged.	
31	No. 376w	8/6 10/6 11/6 16/6	
	No. 377w	9/6 11/6 13/- 18/-	
34	No. 418w	6/- 6/6 6/9	
35	No. 429w	14" size Cancelled.	
	No. 430w	12/- 12/6	
37	No. 445w	12/6	
	No. 448w	9/6	
	No. 451w	10/-	
39	No. 468w	4/6	
	No. 470w	10/6	
43	No. 500w	(not 530w) Clark's Pattern Bit	
	No. 505w	20/- 27/-	
45	No. 523w	2/3	
	No. 524w	2/4 2/7	
47	No. 540w	2/2 2/4 2/6	
53	No. 580w	Handles 3/- pair.	
	No. 581w	Handles 3/- pair.	
	No. 582w	Handles 3/- pair.	
	No. 584w	Extra Handle 1/6	
55	No. 606w	Dixton's Make 6/-	
57	No. 616w	10/6	
58	No. 620w	Leather Roll 7/-	
	No. 626w	14/-	
	No. 634w	11/6	
	No. 636w	3/6	
	No. 637w	6/- 6/6 7/- 8/-	
59	No. 644w	7/-	
	No. 645w	7/-	
	No. 646w	10/6	
	No. 647w	15/-	
61	No. 675w	3/6 pair.	
62	No. 694w	8/9	
64	No. 712w	No. 0 1 2 3 4 5 6 7 8 1/- 1/1 1/2 1/5 1/8 1/11 2/3 2/6 2/9	
66	No. 755w	12/- 12/6 13/6	
68	No. 801w	1/3	
70	No. 804w	1/2 3/4 1 1 1/2 2 pint. 2/6 3/- 3/9 4/6 5/3 6/6	
	No. 805w	The 1/2 pint size has Screw Filling Top. 3/6 3/10 4/4 5/- 6/- 7/- pint.	
	No. 813w	15" 18" 24" 30" 36" 42" 5/3 6/- 6/6 7/3 8/- 9/-	
		12" size Cancelled.	
73	No. 831w	2/6 3/- 3/6 4/- 5/- 5/6	
74	No. 843w	19/6 21/-	
	No. 845w	32/6	
	No. 846w	20/-	
	No. 847w	33/-	
75	No. 852w	5/6	
	No. 856w	Made with Wood Stop only.	
77	N9. 867w	Cancelled.	
81	No. 892w	2" size Cancelled.	
84	No. 896w	19/6	
	No. 897w	Set of 12, 27/-	

PAGE.	No.	Description	Price
85	No. 907w	5/9 7/-	
	No. 910w	Are Straw Coloured Tools.	
86	No. 914w	5/3 6/3	
89	India Stones.	No. 15 16 19 20 22 1/2 2/9 4/2 2/9 2/1 5/3 23 24 25 40 41 42 1/8 4/2 1/8 1/6 2/1 2/9 50 54 56 58 61 62 3/2 3/9 2/1 3/2 10d. 4/2	
	No. 936w	Bottles Cancelled.	
90	No. 938w	6" 8" 10" 12" 14" 18" York 2/6 3/3 4/- 5/9 6/3 8/3 Bilston 3/9 5/3 6/9 8/3 10/6 14/6 20" 24" 26" 28" 30" 36" York 13/6 19/6 22/6 27/- 39/- 66/- Bilston 19/6 30/- 36/- 50/- 60/- 100/-	
91	No. 946w	18" x 3" - £2 17 9, £3 5 9, £4 2 0, £4 8 6 18" x 4" - £3 3 0, £3 12 6, £4 12 6, £4 18 9	
	No. 947w	24" x 4" - £4 9 6, £4 17 9, —	
	No. 948w	£8 14 6 £7 17 6 £10 10 0	
93	No. 957w	17/6 24/- 27/-	
94	No. 971w	Illustration incorrect. Price as illustrated, 45/-. Heavier and Better Pattern, 62/6	
95	No. 973w	6/6	
	No. 978w	40/- 55/- 80/- Cheaper Quality, 18/- 24/-	
	No. 979w	36/- 39/- 42/6 45/-	
97	No. 996w	13/6	
	No. 997w	15/-	
98	No. 1011w	All sizes now made of Lignum.	
101	No. 1057w	5/3 5/6 5/9	
	No. 1058w	9/6	
	No. 1059w	7/-	
	No. 1063w	8/- 8/9 9/-	
106	No. 1125w	Nos. 1 and 2 Cancelled. No. 3, 6/-	
107	No. 1128w	Cancelled.	
108	No. 1143w	12/-	
109	No. 1161w	4/6 4/6 5/- 5/6 6/- 6/9	
111	No. 1189w	6d.	
116	No. 1255w	No. 5, 13/6. No. 6, 25/-	
	No. 1256w	No. 7, 18/- No. 8, 20/-	
122	No. 1296w	Prices quoted include Fast Pulley only. Fast and Loose Pulleys, as illustrated, 25/- extra.	
123	No. 1299w	12" 14" 16" 18" 20" 24" 36/- 43/- 49/- 54/- 57/- 69/- 26" 30" 36" 42" 48" 75/- 80/- 105/- 123/- 160/-	
128	No. 1303w	£14 17 6 £18 15 0	
138	No. 1342w	12 Drawers, 12/6 14 Drawers, 14/6	
139	No. 1349w	Now supplied with 3 trays = 36 divisions.	
140	No. 1359w	£7 6 0 £9 6 0 £10 10 0	
141	No. 1361w	£5 18 6 £6 17 6 £8 2 6	
147	No. 1374w	Cross Fence, 7/6 extra.	
148	No. 1376w	Nos. 1 and 2 Cancelled. For "Safety Circular Type" read "Safety Cutter Block."	
156	No. 1417w	13/6	
161	No. 1452w	27/- 33/- 42/- 48/- 54/- 62/- 67/6 75/-	
	No. 1453w	30/- 36/- 45/- 50/- 56/- 63/- 76/- 111/- 135/-	
164	No. 1461w	Cancelled.	
167	No. 1477w	Machines with Ring-Oiling Bearings Cancelled. 30" x 9" size Cancelled entirely.	

No. 25

WOODWORKERS' CATALOGUE

Bronze Medal
1884



Gold Medal
1890

Awards for Excellence of Machines & Tools

ESTABLISHED 1828

RICHARD MELHUISSH LTD

Tool and Machinery Merchants

Retail, Wholesale, and Export

Nos. 50, 51, 84 FETTER LANE, HOLBORN CIRCUS
LONDON, E.C.4

Branch: 143 HOLBORN, E.C.1

CONTRACTORS TO: THE ADMIRALTY; AIR MINISTRY; HIS MAJESTY'S INDIAN AND COLONIAL GOVERNMENTS; ROYAL ARSENAL AND DOCKYARD; POSTAL TELEGRAPHS DEPARTMENT; TECHNICAL INSTITUTIONS; RAILWAY, MINING, AND INDUSTRIAL COMPANIES THROUGHOUT THE WORLD

IMPORTANT NOTICE

Customers are particularly requested to examine all goods received by Rail or Carrier before signing Delivery Sheet. If not convenient to examine goods at time of delivery, please sign Delivery Sheet "Not Examined," otherwise no claim can be made for damage done in transit, and we cannot undertake responsibility.

1925



PREFACE

WE have pleasure in introducing to our numerous customers our new illustrated Catalogue of Woodworkers' Tools and Machines, and would draw special attention to the fact that the tools illustrated therein are of the best, guaranteed quality.

The quality of our goods is well known; our reputation of close on 100 years for selling the best goods only has placed the firm of RICHARD MELHUISH, LTD., amongst the leading ones of its kind, and the policy which has resulted in this will be continued in the future.

Guided by long and wide experience, we have embodied in our new Catalogue a large and useful selection of all the best designs and inventions which have been placed on the world's markets since the issue of the last edition of this book.

As these new patterns have been brought out, so has our stock proportionately increased. It is now of such variety and extent that we can confidently say that as regards Wood- and Metal-workers' Tools, it is one of the largest in the kingdom. It follows, therefore, that we are in a unique position to give exceptionally prompt delivery to all orders.

OTHER PUBLICATIONS

- No. 20. Engineers' and Motor Tools, Machinery, etc.
- No. 17. Builders' and Furnishing Ironmongery.
- No. 24. Garden Tools.
- No. 23. Cutlery, etc.
- Booklets on Wireless Sets and Component Parts.
- Electrical and Sanitary Goods.

RICHARD MELHUISH, LTD.

Retail, Wholesale, and Export Tool and Machinery Merchants

50, 51 & 84, FETTER LANE, HOLBORN CIRCUS, & 143, HOLBORN, LONDON, E.C.

Telegrams: "WORKFOLK, LONDON"

Telephone: CENTRAL 3156 (3 LINES)

This entire book is COPYRIGHT, 1925.

Entered at Stationers' Hall

IMPORTANT

ORDERS.—Please give name, number, and size of each article required ; these will be quite sufficient to enable us to execute your orders. Do not cut or mutilate this book ; we shall always be pleased to send you loose sheets. It will greatly assist you to write your inquiries, etc., on our specially designed and copyright **Order Forms** ; a supply of these will be posted to you on application.

PRICES.—We respectfully remind our customers that prices are subject to alteration. Orders will be executed at prices according to list, but if it is found impossible owing to advances in the cost of materials, etc., advice will be given before dispatching the goods. If, on the other hand, reductions take place, our friends will get the benefit.

DELIVERY.—For England, Scotland, and Wales, orders of 40/- and upwards in value (except where otherwise stated in Catalogue) are sent Post Free, or Carriage Paid to the nearest Railway Station. For Ireland, orders of £5 and upwards in value are sent Carriage Paid to the nearest Port ; if under 11 lb. in weight and of 40/- in value, Post Free.

ARRANGEMENTS HAVE BEEN MADE with the London Railway Depots, Carriers, and the Parcel Post Department for the regular collection of goods, and we endeavour to dispatch all orders either on the same day, or at most within a day or two after they are received.

PACKAGES.—We make no charge for packing, but all packages are charged and allowed for in full when received by us Carriage Paid and in good condition. Customers should therefore, when returning empties, advise us to this effect the **Same Day**, and should also allow our Labels to remain on the packages, in order that we might identify the sender.

EXPORT.—The prices in this Catalogue for all Export Orders are F.O.B., London, and are subject to charges for special packing, which is priced at Net Cost. Where special limits of size and weights of packages are necessary, our customers will please advise us on their indents.

In order to ensure complete satisfaction, we advise our customers to be careful, when ordering through Shippers, to give clear and definite instructions that the goods shall be procured **direct from our House**. By these means they may be sure of receiving the patterns and quality specified in our Catalogue.

BREAKAGES.—We employ experienced Packers and take great care in the prompt dispatch of all goods from our extensive stock, but we cannot take the risk of breakage of Machines, Grindstones, etc. Carriers will only take these at Owner's Risk, and our responsibility ceases when we have delivered such goods to the Carriers and have obtained their clear receipts for same. In case of breakage the claim must be made to them direct ; if any difficulty, please advise us. Examine all goods before signing Carrier's Delivery Sheet.

LEDGER ACCOUNTS.—We shall be pleased to open Ledger Accounts on Approved References, or Customers may open a Deposit Account so that goods may be drawn from time to time as required.

Where Ledger Accounts have not been arranged, however, our terms are CASH WITH ORDER, and Cheques, Postal Notes, Drafts, etc., should be crossed, " LLOYDS BANK, HOLBORN CIRCUS, LONDON, E.C."

ILLUSTRATIONS are not binding, they are to show in a general way items offered.

INDEX

	PAGE		PAGE
A			
Adzes	66	Caulking Tools	110
Angle Divider	61	Centre Bits	44, 48
Angular Bit Stock	112	Centrifugal Drills	105
Archimedian Drills	37, 105	Chalk Lines and Reels	110
Auger Handles	107, 112	Chamfer Shaves	23, 24
Augers	42	Chests of Drawers	138
Automatic Drills	37	.. of Tools	154, 135, 136
Awls (Marking)	38	Chimney Sweeping Machines	161
Axes	66	Chisel Knives	96
B			
Bag Hooks	110	Chisels	32, 33, 34, 109
Band Saw Machines 129, 131, 132, 133, 134		Chucks (Boxwood)	108
.. .. Soldering Device	129	.. (Lathe)	41
.. .. Saws	55	Circular Saw Benches	122-132, 149
Basket Makers' Tools	149 Saws	56
Bender (Hand)	22	Closing Pliers (Bent Iron Work)	108
Bellhangers' Drills	44	Coachmakers' Routers	21
.. .. Gimlets	139	Cold Chisels	109
Bench Chops	75	Compass Saws	52
.. .. Hooks	79	Compasses	107
.. .. Knives	67	Coopers' Tools	64, 66
.. .. Screws	93	Coping Saws	55
.. .. Stops	75	Cork Rubbers	111
Benches	140, 141, 142, 143	Corner Bit Brace	112
Bevels	60 Cramps	77
Bill Hooks	67	Cornering Tools	20
Bit Gauges	46	Corrugated Iron Chisel	109
.. .. Holders	57, 79 Punch	109
.. .. Rolls	57	Countersinks	36, 45, 47
.. .. Stock Drills	44	Cramp Heads	74
Bits	42-47	Cramps (Joiners')	72
Blind Nail Tool	61	Cross-cut Saws	52, 53
Blow Lamps	97	Cutter and Chisel Grinder	95
Bonsa Tool Sets	154, 155	Cutting Gauges	62
Books (Technical)	19	D	
Boring Machines	147, 158	Depth Gauges	46
Box Scrapers	20, 65	Diamond Hand Turning Tool	95
Boxes and Taps	68	Diamonds	94
Brace Bits	42-47	Dovetailing Bits	47
.. .. Extension Pieces	41	Dowel Bits	42
.. .. Jaws	41 Tools	112
Braces	40, 41, 112	Dowels	112
Brad Punches	47	Drain Cleaning Machines	161
Bradaws	38	Draughtsmen's Squares	118
Brewers' Gimlets	139	Draw Bore Pins	33
Bricklayers' Tools	101, 102 Knives	25
Broom Hooks	67	Drawer Lock Chisel	109
Builders' Screens	159	Drawing Boards	118
.. .. Sieves	159 Instruments	118-121
.. .. Squares	61	Drill Brace	41
Butt Gauges	57	Drills	36, 37, 44
Button Gauges	29	E	
.. .. Hole Chisels	33	Electricians' Chisel	108
.. .. Pliers	166	End Cutting Nippers	104
Burn Brands	90	Expansion Drill	108
Burnishers	106	Expansive Bits	43
C			
Cabinet Scrapers	20	Extension Pieces	41
Calliper Gauge	67	Eyelet Beds and Punches	166
Carpet Stretchers	106 Closing Pliers	103
Carpenters' Benches	140 Punch and Closer	166
.. .. Pencils	156	Eyelets and Rings	166
Carriage Key	108	Eyeletting Machines	165
Carvers' Punches	85	F	
.. .. Screws	85	Farriers' Knives	67
Carving Routers	21	File Card	108
.. .. Tools	82-85 Cleaners	111
Case Openers	65	G	
F			
Files and Rasps	71	G Cramps	73
Floor Cramps	74, 144	Gauges	62
Fork Shaft Rounders	8	Gimlets	139
Forstner Bits	46	Glass Circle-Cutter	94, 95
Fret Files	108 Cutters	95
.. .. Machines	157 Top Boxes	111
.. .. Work Tools	156 Tube Cutter	95
H			
Hammer Handles	68	Glaziers' Knives	96
.. .. Pincers	64 Squares	30
Hammers	64, 65, 102, 106	Glue	113
Hand Bender	22 Pots	113
.. .. Drill	105	Gouges	34
.. .. Punch	103	Graining Combs	97
.. .. Rail Punch	109	Gravel Screens	159
.. .. Saws	50, 51, 52 Sieves	159
.. .. Screws	93	Grindstone Dressers	92
Handles	68, 69, 108 Spindles	92
Hatchets	66	Grindstones	90, 91, 92
Holdfasts	75	Grooving Saws	56
Hollow Augers	49	I	
Hoop Iron Punch	109	Ivory Rules	30
J			
Jacks (Timber)	160	J	
Jig Saw	126	Jacks (Timber)	160
Joiners' Dogs	110	Jig Saw	126
.. .. Name Stamps	90	Joiners' Dogs	110
.. .. Squares	60 Name Stamps	90
Jointer Gauges	12 Squares	60
L			
Ladders	162, 163	Jointer Gauges	12
Ladles	99	L	
Lath Hammers	102	Ladders	162, 163
Lathe Chucks	41	Ladles	99
Lathes	150-152	Lath Hammers	102
Lead and Zinc Cutter	97	Lathe Chucks	41
Leather Shears	100	Lathes	150-152
.. .. Workers' Tools	100	Lead and Zinc Cutter	97
P			
Pliers	108	Leather Shears	100
.. .. Cleaners	111 Workers' Tools	100

INDEX—continued

	PAGE		PAGE		PAGE
Letters and Figures	117	Pit Saws	53	Spoke Trimmers	49
Level Sights	61	Plane Fittings	21	Spokeshave Irons	18
" Tubes	26	Handles	68	Spokeshaves	23, 24
Levels	25-27	Iron and Chisel Grinder	95	Squares	30, 60, 61, 102, 118
Lever	160	Irons	9, 18	Stair Gauge Fixtures	61
Line Pins	110	and Moulding Iron Grinder	130	Gauges	61
Linoleum Knives	96	Planes	6-17, 20, 57	Stapling Machines	164
Lip and Spur Bits	47	Planing Machines	148, 167	Stencils	117
Lock Mortise Chisel	34	Plasterers' Tools	101, 108	Steps	163
M		Plug Cutters	47	Straight Edges	115
" Maco " Templates	79	Plugging Chisels	109	Strip Iron	85
Mallets	85, 98, 110	Plumb Bobs	25	Surveying Levels	25
Marking Awls	38	Plumbers' Tools	97, 98, 108	Surveyors' Laths	28
Gauges	62	Plumbs and Levels	25, 27	T	
Masons' Tools	101, 102	Poker Work Machines	100	T Squares	30, 118
Matchets	107	Press Buttons	166	Tack Lifter	65
Measuring Tapes	31	Protractors	119	Tacking Machines	164
Melting Pots	99	Pruning Saws	52	Tailor's Square	30
Mitre Blocks	79	Punch Pliers	103, 104, 166	Tape Measures	31
Box Saws	57	Punches	47, 109, 166	Taper Bits	44
Boxes	78, 79	Punching Machine	166	Tar Brushes	114
Machine and Cramp	77	Push Brace	37	Technical Books	19
Machines	17, 80	R		Outfit	43
Planer	81	Rasps and Files	71	Templates (Mitre)	79
Squares	60	Ratchet Braces	40, 41	(Ovolo)	7
Templates	79	Screwdrivers	36	Tenon Saws	54
Mortar Larrie	102	Rawplug Outfits	109	Timber Dogs	110, 160
Mortise Gauges	62	Rebating Gauge	115	Jack	160
Machine Chisels	33	Reciprocating Drills	37	Scribers	67
Machines	144-146	Reeding and Moulding Tools	22	Tobacco Cutter	67
Moulders' Tools	67	Repoussé Tools	105	Tool Bags	107, 108
Mount Cutters' Knives	77	Rifflers	85	Cabinets	137, 138
" " Straight Edges	115	Rimers	44	Chests	134-136
N		Rope and Chain Gauge	29	Clips	111
Nail Boxes	139	Rounders (Wheelers')	8	Cupboards	134
Pullers	65	Routers	21, 22, 23	Grinding Rests	95
Sets	47, 109	Rubber Knives	67	Racks	111
Name Stamps	90	Rule Attachments	63	Rolls	57, 155
Needles	106	Rules	28, 29, 30, 102, 108, 118	Sets	39, 108, 154
Nests of Saws	52	S		Trammel Heads	63
O		Saddlers' Punches	103	Trowels	101
Odd Jobs	60	Tools	103	Trucks	152, 153
Oil	89	Sanding Machine	147	Turning Saws	58
Cans	70, 111	Sash Pocket Chisels	33	Tools	33, 34
Oilstones	85-90	Saw Benches	122-128, 130, 132, 149	Type Founders' Chisels	149
P		Blades	57	Tyre Wheel	108
Pad Saw Blades	57	Bucks	58	U	
Saws	55	Filers' Vices	58	Universal Cramps	73
Paint Brushes	114-116	Guards	123	Upholsterers' Tools	106
Cans	99	Gulleting Apparatus	129	V	
Mills	99	Handles	68	Vaseline	111
Removing Lamps	97	Screws	58	Vices	93
Strainers	99	Sets	58, 59	Violin Planes	57
Palette Knives	96	Spindles	130	W	
Paperhangers' Brush	115	Saws	50-58	Wad Punches	103
Rollers	96, 97	Scrapers (Cabinet)	20	Wall Drills	109
Shears	96	Screwdriver Bits	44	Plugs	109
Parallel Rules	118	Screwdrivers	35, 36, 39	Scrapers	96
Pencils	156	Scroll Saw	129	Wallpaper Trimmers	97
Piano Keys	108	Set Squares	118	Washer Cutters	104
Picks	160	Shave Hooks	99	Washita Wheels	86
Picture Framing Cramps	76, 77	Ship Scrapers	110	Weighing Machines	161
Piercing Saws	55	Shoemakers' Tools	104	Wheelbarrows	160
Pig Scraper	67	Shooting Boards	17, 81	Wheelers' Bruzz	34
Pin Mauls	110	Shovels	160	Rounders	8
Pincers	107	Sieves	159	Wire Brush	97
		Sill Borer	107	Wood Cramp	73
		Slate Helling Machine	128	Slotting Bits	48
		Slaters' Tools	102		
		Slotting Bits	48		
		Smiths' Drills	44		
		Soldering Lamps	97		
		Spirit Levels	25, 26, 27		

MELHUIH'S CELEBRATED PLANES

These are made from the finest selected Beechwood and are thoroughly seasoned. Best Crucible Cast Steel Irons are used. The workmen are picked from the plane-making trade.

SMOOTHING PLANES



No. 50w.		With Cut Irons.	With Parallel Irons.
Warranted.			
2 in. C.S. Double Iron		7/6	8/- each.
2½ " " " "		8/-	8/6 "
2¾ " " " "		8/6	9/- "
3 " " " "		9/6	10/- "
3½ " " " "		10/6	11/- "
2½ in. with Steel-plated Sole		18/-	18/6 "

DOUBLE IRON JACK PLANES

No. 51w.



All 17 in. long.

Size	2	2½	2¾	3	in.
C.S. Double Irons	9/6	10/-	10/6	12/-	each.
" " Parallel Irons	10/-	10/6	11/-	12/6	"

TECHNICAL JACK PLANE

No. 52w.

Special pattern, with striking button, as supplied to technical schools throughout the country



Length, 14 in.; width of cutter, 2 in.
Price, with Double Irons ... 12/6 each.

TRYING AND JOINTER PLANES

Double Cut Irons.



No. 53w

Size	22 × 2½	24 × 2½	26 × 2½ in.
Price	14/6	15/-	16/9 each.

If with Parallel Iron, -/9 extra.

2 IN. COMPASS SMOOTH

No. 54w.



With best Double Irons 17/-
Do., with Boxwood Stop 17/-
Do., without Stop ... 8/6

OLD WOMAN'S TOOTH PLANE

No. 55w.



With one Iron ... 6/6
Size of Irons, ¼-½ in.

2 IN. TOOTHING PLANE

No. 56w.



Coarse or fine Iron.
6/6 complete.

SMOOTH PLANE

No. 57w



With improved front.
Size ... 2 2½ 2¾ in.
Price ... 17/- 18/- 19/- each.

BEAD PLANES

No. 58w.



Size, ¼-½ in	...	price	5/-	Set of 8 Beads, ¼-1 in.	...	price	45/-	
" ½ in	...	"	5/3	" 10 " ¼-1 "	...	"	55/-	
" ¾ "	...	"	5/6	" 8 " slipped to ½ in.	...	"	49/-	
" 1 "	...	"	6/-	" 10 " " ½ "	...	"	64/-	
Slipped Beads, 1/- each extra.				Size	...	½	¾	1 in.
				2 Reeds	...	8/-	8/3	8/6 each.
				3 "	...	9/3	9/3	9/6 "

REEDING PLANES

No. 59w.



REBATE PLANES

No. 60w.

SQUARE MOUTH

Size...	½	¾	1	1½	2	2½	in.
Price	5/-	5/-	5/-	5/-	5/-	5/-	each.
Size ...	1	1½	1¾	2	2½	2	in.
Price...	5/-	5/-	6/-	7/-	8/-	8/-	each.

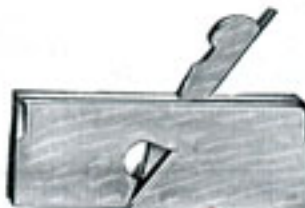

No. 61w.

SKEW MOUTH

Size...	½	¾	1	1½	2	2½	in.
Price	5/3	5/3	5/3	5/3	5/3	5/3	each.
Size ...	1	1½	1¾	2	2½	2	in.
Price...	5/3	5/3	6/3	7/3	8/3	8/3	each.

TOOL AND MACHINE MERCHANTS

HOLLOW AND ROUND PLANES

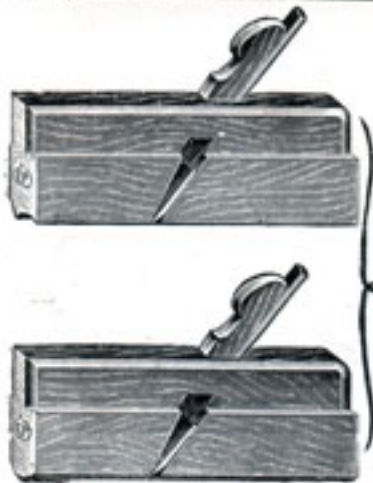

Skew mouth

No. 62w.

Price per pair to No. 15	10/-
.. .. No. 16	10/6
.. .. " 17	11/-
.. .. " 18	11/6
.. per set of 9 pairs	89/-
.. .. " 18	178/-

No. 63w. Side Rounds price 9/6 per pair.

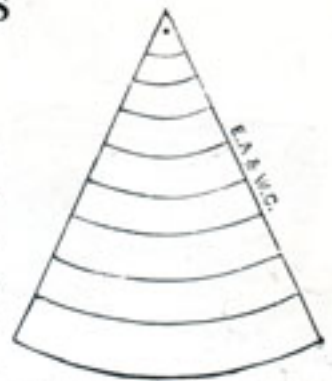

Sections of Hollows and Rounds.

GROOVING OR MATCHING PLANES

No. 64w.

Size...	$\frac{1}{2}$	$\frac{3}{4}$	1	$1\frac{1}{4}$	$1\frac{1}{2}$	$1\frac{3}{4}$	2	in.
Price	11/-	11/-	11/-	11/-	11/9	12/-	12/-	pair.

ADJUSTABLE MATCHING PLANES

No. 65w. With 3 pairs Irons, price 26/- per pair.

DADO GROOVING

No. 66w. With Wood Stop	9/- each.
.. 67w. .. Screw Stop	13/- ..

DRAWER BOTTOM PLANE

No. 68w. Price	6/- each.
.. 69w With Fence	9/- ..

PLANES MADE TO DRAWINGS

Please send us your
Inquiries.

DADO GROOVING

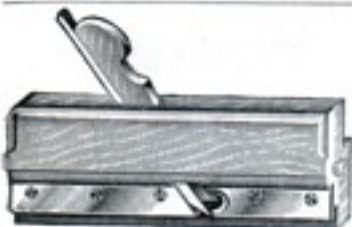

OVOLO SASH PLANES

No. 70w.

Size ...	$\frac{1}{2} \times 1\frac{1}{2}$	$\frac{3}{4} \times 1\frac{1}{2}$	1×2	in.
Price ...	11/-	11/6	12/-	per pair.

Templates for same, 3/- per pair.

ILLUSTRATION OF "LAMB TONGUE" SASH

No. 71w.



"LAMB TONGUE" SASH PLANES

No. 72w.

Size ...	$\frac{1}{2} \times 1\frac{1}{2}$	$\frac{3}{4} \times 1\frac{1}{2}$	1×2	in.
Price ...	16/-	16/6	17/-	per pair.

Templates extra.

OVOLO TEMPLATES

No. 73w.

Price ... 3/- per pair.

No. 74w.

Ditto, improved Brass

End Templates.

Price ... 10/- per pair.



MOULDING PLANES

QUIRK OGEE

No. 75w.



Sizes to ...	$\frac{1}{2}$	$\frac{3}{4}$	1	in.
Price ...	7/3	7/6	8/-	8/9 each.

COM- MON OVOLO

No. 76w.



Sizes to...	$\frac{1}{2}$	$\frac{3}{4}$	1	in.
Price ...	5/3	5/9	6/3	6/9 each.

COM- MON OGEE

No. 77w



Sizes to	$\frac{1}{2}$	$\frac{3}{4}$	1	in.
Price...	5/3	5/9	6/3	6/9 each

Builders' and Furnishing Ironmongery

PLOUGH PLANES

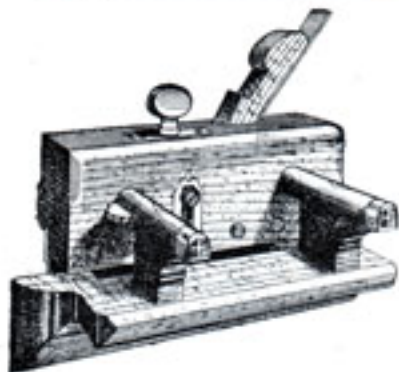

- No. 78w. Wood Stop, 6 Black Irons ... 21/-
- 79w. Screw Stop, 8 " ... 30/-
- 80w. Improved Side Stop, Double Hooped Stems ... 42/-
- 81w. Ditto, Skate End ... 45/-
- 82w. Ditto, Beech Screw Stems ... 46/-
- 83w. Ditto, Box " ... 54/-



Nos. 82w and 83w may be supplied with the following extras: Box Fence, 4/-; Handle, 12/-

The last four numbers have eight best bright Irons.

MOVING FILLISTER



- No. 84w. With Brass Slip Stop. Price 11/-
- No. 85w. Do., with Tooth, and boxed. Price 13/-
- No. 86w. Brass Screw Stop, Forked Tooth, and Shoulder boxed. Price 20/-
- No. 87w. As above, but with improved Fence. Price 21/6

- No. 88w. With Wood Stop ... Price 13/-
- No. 89w. With Brass Screw Stop. Price 19/-
- No. 90w. With Brass Screw Stop, and Capped Stems ... Price 24/-
- No. 91w. Shoulder Boxed, left hand, Forked Tooth, improved Stop. Price 36/-

SASH FILLISTER



"T" REBATE

- No. 92w. Price 8/-
 - " 93w. Ditto, with Box Face ... 12/-
 - " 94w. Compass... 9/-
 - " 95w. Convex ... 9/-
- All above Planes are 1 1/2 in. wide.

COACH SMOOTH

- No. 96w. 1 1/2 in. cutter. Price ... 7/6

STOP CHAMFER PLANE

- No. 97w. With Fence as shown. Price 13/6
- No. 98w. Without Fence. Price 10/-

"V" CHAMFER PLANE

- No. 99w. Price 6/-
- " 100w. Do., solid boxed. Price 7/-

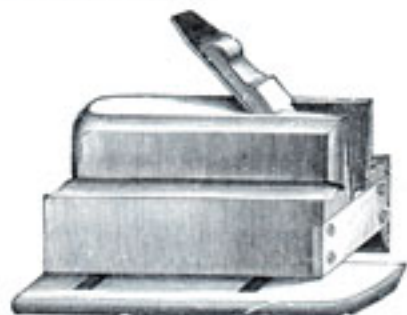

SHUTEING PLANE

- No. 101w. Length, 22 in.; 3 in. cutter. Price 27/-
- No. 102w. As above, Skew mouth. 3 in. cutter. Price 31/-



SHUTEING PLANE

- No. 103w. Length, 22 in.; width of cutter, 3 in. With Plated Sole, Skew Mouth. Price 48/-

MITRE PLANE

- No. 104w. Length, 12 in.; 2 1/2 in. Iron, Skew Mouth. Price 11/-



JACK PLANE

- No. 105w. Single. 1 1/2 in. Iron; length of Plane, 10 in. Price 7/9
- No. 106w. If with Ram's Horn instead of Peg. Price 10/-



MELHUISH'S PLOUGH

- No. 107w. New pattern Plough Plane, with quick-acting adjustment by wing nuts and wood screw stems. Brass Screw Stop. Price, with 6 cutters, 35/- each.

ROUNDERS (Wheeler's)



- No. 108w. Tapering: 3/4 x 3/4, 1 x 3/4, 1 1/4 x 1, 1 1/2 x 1 1/4 in. Price 10/6, 10/6, 11/3, 12/- each.

FORK SHAFT ROUNDERS

- No. 109w. Plain ... 21/- each. Brass-plated ... 31/6 "

TOOL AND MACHINE MERCHANTS

CELEBRATED ENGLISH STEEL PLANES

SPECIALLY RECOMMENDED FOR PLANING HARD WOODS.

IMPROVED STEEL SMOOTHING PLANE

Fitted with rosewood and gun-metal lever.

No. 110W.



Width of cutter ... 2½ ... 2½ in.
Price ... 46/- ... 47/- each.

STEEL JOINTING AND PANEL PLANES

All fitted with 2½ in. cutters.
Fitted with rosewood and gun-metal lever.

No. 111W.



Length 13½ 14½ 15½ 16½ 17½ 20½ 22½ 25½ 28½ in.
Price ... 60/- 62/- 64/- 66/- 68/- 72/- 75/- 85/- 95/- each.

STEEL REBATE PLANE

Fitted with rosewood.

No. 112W.



Size ... 6 × ½ 8 × ½ 9 × 1 in.
Price ... 19/- 23/6 27/6 each.
Skew mouth, 2/- extra.

MALLEABLE IRON SMOOTHING PLANE

Fitted with rosewood and gun-metal lever.

No. 113W.

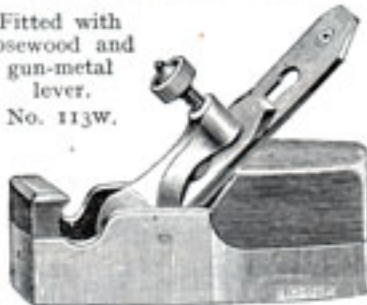

Width of cutter 2 2½ 2½ in.
Price ... 32/- 34/- 36/- each.

IMPROVED STEEL SMOOTHING PLANE

Round sides.

Fitted with rosewood and gun-metal lever.

No. 114W.



Width of cutter ... 2½ 2½ in.
Price ... 38/- 39/- each.

STEEL SHOULDER PLANE

Fitted with rosewood.

No. 115W.



Size... 6 × ½ 7 × ½ or 7 × ¾ 8 × 1 8 × 1½ 8 × 1½ in.
Price ... 22/- 26/- 32/- 33/- 34/- each.
Skew mouth, 2/- extra.

STEEL MITRE PLANE

Fitted with rosewood and gun-metal lever.

No. 116W.



Size, 10½ × 2½ in. ... price 39/- each.
No. 117W. Skew mouth ... 42/- ..

STEEL SHOULDER PLANE

Fitted with rosewood.

No. 118W.



Size ... 7½ × 1½ 7½ × 1½ in.
Price ... 31/- 33/- each.

No. 119W.

Gun-metal with steel face.

Size ... 8 × 1½ 8 × 1½ in.
Price ... 44/- 46/- each.
Skew mouth, 2/- extra.

MALLEABLE BULLNOSE PLANES

Fitted with rosewood.

No. 120W.



Size ... 1 1½ 1½ in. cutter.
Price... 15/6 16/6 17/6 each.

No. 121W.

Gun-metal with steel face.

Size ... 1 1½ 1½ in. cutter.
Price... 21/- 22/6 23/- each.
Extra Iron, 2/3 each.

STANDARD PLANE IRONS

No. 122W.

For above planes. Ground bright; quite flat and parallel.



Size ... 2 2½ 2½ 2½ in.
Price ... 2/9 3/- 3/3 3/9 each.

Top Iron, with screw.

No. 123W.



Price ... 2/3 each.

Jointer, Panel, and Smooth Planes may be fitted with Patent Adjustment for the Cutter at 4/- extra.

Electric and Wireless Engineers

PATENT ADJUSTABLE TABLE IRON PLANES

Stanley and Sargent Cos'.



Planes made by the Stanley Co.

No.	Description	Price.
124W/1.	Smooth, 5½ in. long, 1¼ in. cutter ...	10/-
125W/2.	" 7 " 1½ " ...	13/-
126W/3.	" 8 " 1¾ " ...	13/9
127W/4.	" 9 " 2 " ...	14/10
128W/4½.	" 10 " 2½ " ...	17/-
129W/5.	Jack, 14 in. long, 2 in. cutter...	17/-
130W/5½.	" 15 " 2¼ " ...	19/3
131W/6.	Fore, 18 " 2½ " ...	22/-
132W/7.	Jointer, 22 in. long, 2¾ in. cutter ...	25/3
133W/8.	" 24 " 2¾ " ...	30/-

Planes made by the Sargent Co.

No.	Description	Price.
134W/407.	Smooth, 7 in. long, 1½ in. cutter ...	11/-
135W/408.	" 8 " 1¾ " ...	12/-
136W/409.	" 9 " 2 " ...	14/-
137W/410.	" 10 " 2½ " ...	16/-
138W/414.	Jack, 14 in. long, 2 in. cutter ...	16/-
139W/415.	" 15 " 2¼ " ...	18/-
140W/418.	Fore, 18 " 2½ " ...	20/6
141W/422.	Jointer, 22 in. long, 2¾ in. cutter ...	23/6
142W/424.	" 24 " 2¾ " ...	28/-

" STANLEY " PATTERN WITH " BED-ROCK " IMPROVEMENT

In the " Bed-Rock " Plane a design has been perfected which effects a combination of the utmost rigidity with a wider range of adjustments than hitherto. The portion of the Plane to which are attached the fine adjustments is known as the " Frog," which in the " Bed-Rock " pattern is made with MACHINED FACE. The frog is also designed so that its entire bottom rests solidly on a seat formed on the plane body. By the new design the sides of the frog also conform to guides formed in the body of the plane, the guides lending accuracy of adjustment to the frog, as well as preventing any possibility of wobbling. A reliable adjustment for width of throat opening is another important feature of the " Bed-Rock " design. Both the ordinary and " Bed-Rock " Planes are fitted with the same pattern plane irons.



No.	Description	Price.
143W/603.	Smooth, 8 in. long, 1¾ in. cutter ...	16/6
144W/604.	" 9 " 2 " ...	18/3
145W/604½.	" 10 " 2½ " ...	20/9
146W/605.	Jack, 14 in. long, 2 in. cutter ...	20/9

No.	Description	Price.
147W/605½.	Jack, 15 in. long, 2¼ in. cutter ...	23/6
148W/606.	Fore, 18 " 2½ " ...	26/9
149W/607.	Jointer, 22 in. long, 2¾ in. cutter ...	30/6
150W/608.	" 24 " 2¾ " ...	36/6

CARRIAGE MAKERS' REBATE PLANES

Especially adapted for the heavy framing required in mining work, for carriage or wagon building, or in any work of similar nature. Adjustable cutters. Rose-wood handles and knobs.

The No. 10½ has all the features of Nos. 10 and 10½, and, in addition, both the handle and knob can be tilted to either side, enabling Plane to work close to perpendicular sides. Spurs are fitted to both sides of the plane.

No. 151W/10½.	9 in. long, 2½ in. cutter. Price 18/-	No. 152W/10.	13 in. long, 2½ in. cutter. Price 21/6
No. 153W/10¼.		13 in. long, 2½ in. cutter. Price 26/-	

Bronze Medal 1884—Gold Medal 1890

TOOL AND MACHINE MERCHANTS

STANLEY BLOCK PLANES

No. 154w.



5½ in. long, 1½ in. cutter... price 2/11
Spare Iron -/10

LOW ANGLE, AND WITH ADJUSTABLE THROAT

No. 157w.



6 in. long, 1½ in. cutter. Japanned, price 9/-
Extra Iron 1/8

BLOCK AND REBATE

No. 160w.

A detachable side changes it from a Block to a Rebate Plane. Skew cutter.



7 in. long, 1½ in. cutter. Japanned, Rose-wood knob.
Price 10/3
Extra Iron 2/-

ADJUSTABLE, NICKELLED KNUCKLE JOINT

No. 163w.



7 in. long, 1½ in. cutter price 12/-

DUPLEX, FILLISTER, AND REBATE PLANE

No. 166w.

Has two seats for the cutter, one for regular and the other for bullnose work. It has a spur and a removable depth gauge.



The adjustable fence can be used on either side and slides under the bottom. To work as a rebate plane, remove fence and arms.
8½ in. long, 1½ in. cutter... .. price 11/3

No. 155w.



5½ in. long, 1½ in. cutter, lever adjustment.
Price 4/-
Spare Iron -/10

ADJUSTABLE AND NICKELLED

No. 158w.



6 in. long, 1½ in. cutter price 9/8
Extra Iron 1/8

LOW ANGLE NON-ADJUSTABLE THROAT

No. 161w.



6 in. long, 1½ in. cutter. Nickelled, Rose-wood knob.
Price 8/6
Extra Iron 1/8

ADJUSTABLE NICKELLED KNUCKLE JOINT.

No. 164w.



6 in. long, 1½ in. cutter price 11/3

HANDLED IRON REBATE PLANES

No. 167w.

These Planes will lie flat on either side and can be used with right or left hand while planing into corners or up against perpendicular surfaces.

They are fitted with a spur and a detachable depth gauge.



A. 8 in. long, 1½ in. cutter ... price 10/3
B. 8 " 1½ " " " " 9/6
C. 8 " 1 " " " " 8/9

No. 156w.

This has two slots and two cutter seats and is double-ended.



8 in. long, 1½ in. cutter price 5/10
Spare Iron 1/4

ADJUSTABLE AND JAPANNED

No. 159w.



6 in. long, 1½ in. cutter price 8/6
Extra Iron 1/8

JAPANNED, THROAT NOT ADJUSTABLE

No. 162w.



7 in. long, 1½ in. cutter, screw adjustment.
Price 5/10
Extra Iron 1/8

EDGE TRIMMING PLANE

No. 165w.

With Skew Cutter.



6 in. long, ¾ in. cutter price 7/-

DOVETAIL PLANE

No. 168w.

The only Plane manufactured that will cut a dovetail.

It will cut any size grooves and tongues to fit, with sides at flare of 20°, where the

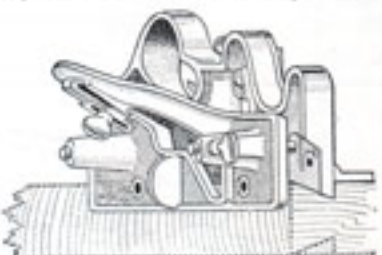

width of the neck is more than ¼ in. and the depth of groove not more than ¼ in. The tongue and groove are cut separately and can be made with parallel or tapering sides.

Nickel-plated, 9 in. long price 41/-

Engineers' Tools and Machinery

RICHARD MELHUISE LIMITED, LONDON, E.C.

UNBREAKABLE DROP FORGED STEEL PLANES

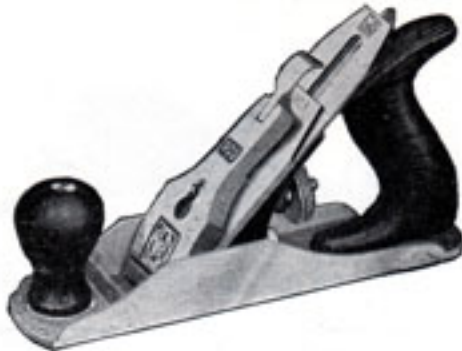

No. 169w. SMOOTH. 8 in. long, 1½ in. cutter. Price 18/-

These are drop forged from a solid bar of Super-steel and are the first unbreakable planes ever manufactured!

Drop forged from solid steel, rather than cast, they have the toughness to withstand a blow from a fall or other cause that would break a brittle cast plane.



No. 170w. JACK. 14 in. long, 2 in. cutter. Price 22/-
No. 171w. SMOOTH. 9 in. long, 2 in. cutter. Price 19/6

STANLEY PLANES REBATE AND FILLISTER PLANE

No. 173w.

This Plane will lie perfectly flat on either side and has an adjustable fence for regulating width of cut.

It is fitted with two spurs and an adjustable depth gauge. The front part of the Plane can be detached for bullnose work. The cutter is adjustable endwise.

Length, 6½ in.; width of cutter, 1 in.
Price 12/- each.



SKEW CUTTER FILLISTER AND REBATE PLANE

No. 174w.

This has an extra wide skew cutter, and an adjustable spur on each side.



The fence and depth gauge can be attached to either side, the fence sliding under the bottom. Remove arms and fence, and a Skew Cutter Rebate Plane is obtained.

Length, 8½ in.; cutter, 1½ in.
Price 14/6 each.

ADJUSTABLE CHAMFER PLANE

No. 172w.

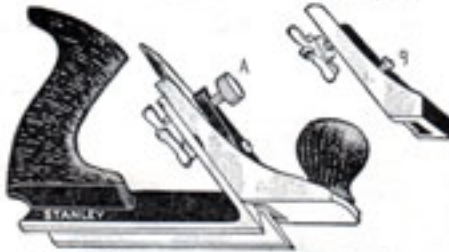

This Plane will do perfect chamfer or stop-chamfer work. It has a 90° V bottom which acts as a mitre guide. To this is attached an adjustable front A, having a flat bottom which carries the cutter. This front can be set for different sizes of chamfer. Front A can be readily detached and a bullnose front, B (furnished with the Plane), substituted, permitting the Plane to be worked close up into corners.

Length, 9 in.; width of cutter, 1½ in.
Rosewood handle and knob.

Price 16/3 each.

SIDE REBATE PLANES

No. 175w.
Right Hand.



For side-rebating in trimming dados, mouldings, and grooves of all sorts. A reversible nose-piece gives the tool a form whereby it will work close up into corners. Fitted with depth gauges.

No. 176w.
Left Hand.



Length, 4 in. Rosewood knob, nickel-plated. Price 7/6 each, either hand.

STANLEY REBATE PLANES

No. 177w.

No. 178w.



These have adjustable throats and may be worked right or left hand. They lay quite flat. All are nickel-plated.

	A.	B.	C.
Length	5½	6½	7½ in.
Price	13/9	16/3	18/8 each.

No. 178w. 4 in. long, 1 in. cutter. Price 13/9 each.

JOINTER GAUGE

No. 179w.



This may be used on all sizes of jack or jointer planes to plane bevels of any angle between 30° and 90°. It may be used on either side of the plane. Nickel-plated.

Price 7/6 each.
No. 180w. For Wood Planes 5/-

THE PERFECT JOINTER GAUGE

For Wood or Iron Planes.

No. 181w.

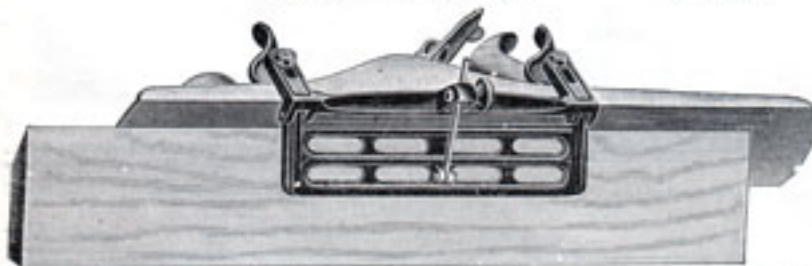

For planing squares or bevels, and can be attached with ease and rapidity to either iron or wood planes.

The arms are slotted to provide for adjustment to the varying heights of iron planes, and adjusting bolts upon which eccentric cams revolve are secured in these slots.

By a partial revolution of the cams the gauge can be attached to or removed from an iron plane instantly.

To use a wood plane the cam bolts are removed and round head wood screws are used in the arm slots instead. The desired bevel is secured by raising or lowering the gauge when it is held firmly in place by the milled edge thumbscrew.

Price, in Enamelled Iron 8/- each.

Builders' and Furnishing Ironmongery

CIRCULAR PLANES

These Planes have adjustable flexible steel faces for planing the inside or outside of circles. Cutters adjustable endwise and sidewise.

VICTOR ADJUSTABLE.

The face is fastened at each end to the Plane body and adjusted by a screw at the centre. This construction gives great strength.

No. 182w.



10 in. long, 1½ in. cutter. Japanned.
Price 22/6

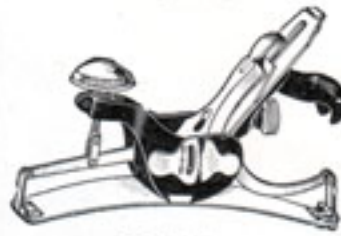

Left Side.

STANLEY ADJUSTABLE

No. 183w.

This has graduated scale for setting the face. Both sides of Plane are shown.

10 in. long, 1½ in. cutter.
Japanned.

Price 22/6



Right Side.

SKREW CUTTER COMBINATION

No. 184w.

For plough, dado, fillister, matching, and rebate work. Fitted with spurs, a depth gauge, and a fence with Rosewood face.



10½ in. long. Nickel-plated, Rosewood handle.

12 cutters as follows:

Plough and dado, ¼, ½, ¾, 1, 1½, 2, 2½, 3, 3½, 4, 4½, 5, 5½, 6, 6½, 7, 7½, 8, 8½, 9, 9½, 10, 10½, 11, 11½, 12, 12½, 13, 13½, 14, 14½, 15, 15½, 16, 16½, 17, 17½, 18, 18½, 19, 19½, 20, 20½, 21, 21½, 22, 22½, 23, 23½, 24, 24½, 25, 25½, 26, 26½, 27, 27½, 28, 28½, 29, 29½, 30, 30½, 31, 31½, 32, 32½, 33, 33½, 34, 34½, 35, 35½, 36, 36½, 37, 37½, 38, 38½, 39, 39½, 40, 40½, 41, 41½, 42, 42½, 43, 43½, 44, 44½, 45, 45½, 46, 46½, 47, 47½, 48, 48½, 49, 49½, 50, 50½, 51, 51½, 52, 52½, 53, 53½, 54, 54½, 55, 55½, 56, 56½, 57, 57½, 58, 58½, 59, 59½, 60, 60½, 61, 61½, 62, 62½, 63, 63½, 64, 64½, 65, 65½, 66, 66½, 67, 67½, 68, 68½, 69, 69½, 70, 70½, 71, 71½, 72, 72½, 73, 73½, 74, 74½, 75, 75½, 76, 76½, 77, 77½, 78, 78½, 79, 79½, 80, 80½, 81, 81½, 82, 82½, 83, 83½, 84, 84½, 85, 85½, 86, 86½, 87, 87½, 88, 88½, 89, 89½, 90, 90½, 91, 91½, 92, 92½, 93, 93½, 94, 94½, 95, 95½, 96, 96½, 97, 97½, 98, 98½, 99, 99½, 100, 100½.

Price 41/-

LIGHT COMBINATION

No. 186w.

A small Combination Plane for light work. Adapted for plough, beading, matching, and rebate work. Fitted with spurs, depth gauge, and a fence with a 5 in. adjustment.

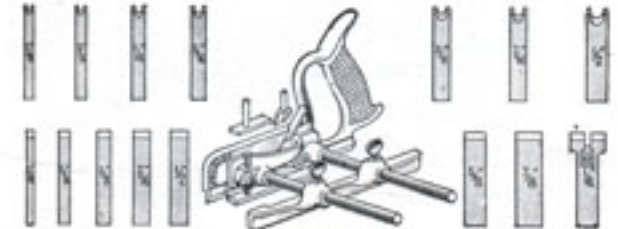

9½ in. long. Nickel-plated.

15 cutters as follows:

Plough and dado, ¼, ½, ¾, 1, 1½, 2, 2½, 3, 3½, 4, 4½, 5, 5½, 6, 6½, 7, 7½, 8, 8½, 9, 9½, 10, 10½, 11, 11½, 12, 12½, 13, 13½, 14, 14½, 15, 15½, 16, 16½, 17, 17½, 18, 18½, 19, 19½, 20, 20½, 21, 21½, 22, 22½, 23, 23½, 24, 24½, 25, 25½, 26, 26½, 27, 27½, 28, 28½, 29, 29½, 30, 30½, 31, 31½, 32, 32½, 33, 33½, 34, 34½, 35, 35½, 36, 36½, 37, 37½, 38, 38½, 39, 39½, 40, 40½, 41, 41½, 42, 42½, 43, 43½, 44, 44½, 45, 45½, 46, 46½, 47, 47½, 48, 48½, 49, 49½, 50, 50½, 51, 51½, 52, 52½, 53, 53½, 54, 54½, 55, 55½, 56, 56½, 57, 57½, 58, 58½, 59, 59½, 60, 60½, 61, 61½, 62, 62½, 63, 63½, 64, 64½, 65, 65½, 66, 66½, 67, 67½, 68, 68½, 69, 69½, 70, 70½, 71, 71½, 72, 72½, 73, 73½, 74, 74½, 75, 75½, 76, 76½, 77, 77½, 78, 78½, 79, 79½, 80, 80½, 81, 81½, 82, 82½, 83, 83½, 84, 84½, 85, 85½, 86, 86½, 87, 87½, 88, 88½, 89, 89½, 90, 90½, 91, 91½, 92, 92½, 93, 93½, 94, 94½, 95, 95½, 96, 96½, 97, 97½, 98, 98½, 99, 99½, 100, 100½.

Price 29/-

CURVE REBATE

No. 188w.

Will cut rebates on the outside or inside of curved or straight edges. It has two adjustable cutters, the upper acting as a spur for the lower and also cutting the side of the rebate. The lower skew cutter cuts the bottom of the rebate. Adjustable depth gauge and fence.

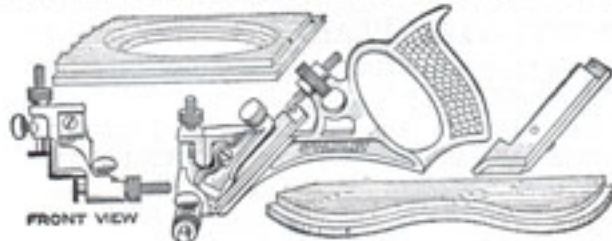

9 in. long. Nickel-plated price 27/6

SWINGING FENCE MATCH PLANES

No. 185w.

These Planes have two plough cutters of the same width and one extra wide cutter. The fence in one setting exposes two cutters for cutting the tongue, and, when reversed, leaves only one exposed for cutting the groove. On thicker boards than the plane works on centre, the extra wide cutter is used when cutting the tongue. Nickel-plated. Rosewood knobs.

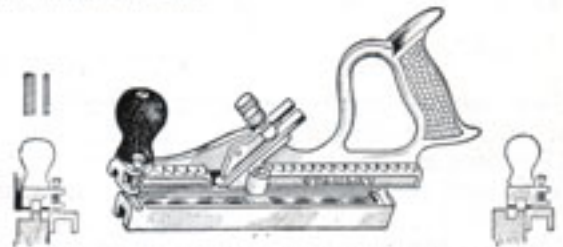

A. Cuts ½ in. groove on boards 1-1½ in. centres on ½ in. .. price 20/-
B. 20/-

BULLNOSE COMBINATION

No. 187w.

For plough, matching, and rebate work. The tool has two interchangeable front parts that make it either an ordinary or a Bullnose Plane. With the Bullnose attachment, it will work into a ¼ in. hole as in sash fitting, stair work, etc. Fitted with a depth gauge and a fence.

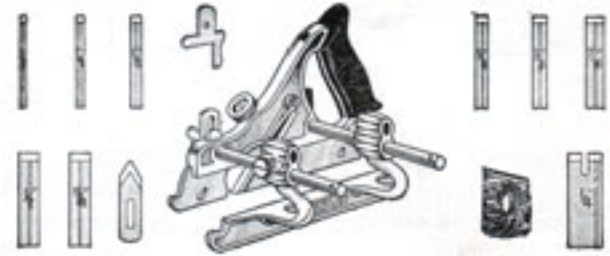

9½ in. long. Nickel-plated, Rosewood handle.

10 cutters as follows:

Plough, ¼, ½, ¾, 1, 1½, 2, 2½, 3, 3½, 4, 4½, 5, 5½, 6, 6½, 7, 7½, 8, 8½, 9, 9½, 10, 10½, 11, 11½, 12, 12½, 13, 13½, 14, 14½, 15, 15½, 16, 16½, 17, 17½, 18, 18½, 19, 19½, 20, 20½, 21, 21½, 22, 22½, 23, 23½, 24, 24½, 25, 25½, 26, 26½, 27, 27½, 28, 28½, 29, 29½, 30, 30½, 31, 31½, 32, 32½, 33, 33½, 34, 34½, 35, 35½, 36, 36½, 37, 37½, 38, 38½, 39, 39½, 40, 40½, 41, 41½, 42, 42½, 43, 43½, 44, 44½, 45, 45½, 46, 46½, 47, 47½, 48, 48½, 49, 49½, 50, 50½, 51, 51½, 52, 52½, 53, 53½, 54, 54½, 55, 55½, 56, 56½, 57, 57½, 58, 58½, 59, 59½, 60, 60½, 61, 61½, 62, 62½, 63, 63½, 64, 64½, 65, 65½, 66, 66½, 67, 67½, 68, 68½, 69, 69½, 70, 70½, 71, 71½, 72, 72½, 73, 73½, 74, 74½, 75, 75½, 76, 76½, 77, 77½, 78, 78½, 79, 79½, 80, 80½, 81, 81½, 82, 82½, 83, 83½, 84, 84½, 85, 85½, 86, 86½, 87, 87½, 88, 88½, 89, 89½, 90, 90½, 91, 91½, 92, 92½, 93, 93½, 94, 94½, 95, 95½, 96, 96½, 97, 97½, 98, 98½, 99, 99½, 100, 100½.

Price 31/-

DOOR TRIM AND ROUTER PLANE

No. 189w.

This Plane will make mortises for butts, face plates, strike plates, escutcheons, up to a depth of ½ in. and a width of 3 in. A fence regulates the position of the cut and ensures the sides being parallel. The depth of the cut is governed by a positive stop.

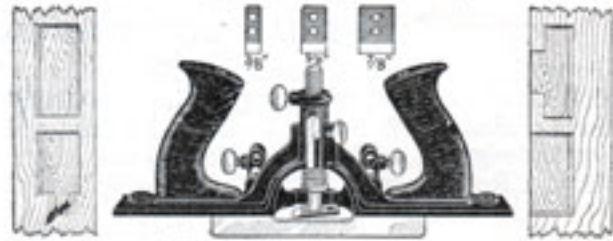

11 in. long. Japanned, Rosewood handle price 22/-

MELHUISS, Ltd., have a separate department with a large and well-assorted stock of Builders' Ironmongery and Cabinet Brass Foundry, also for Electrical Goods, Bells, Lighting, Wireless Equipment, Horticultural Supplies, etc. We carry a large and well-assorted stock, so can forward your esteemed orders at once—no delay. Established 1828.

STANLEY PLANES

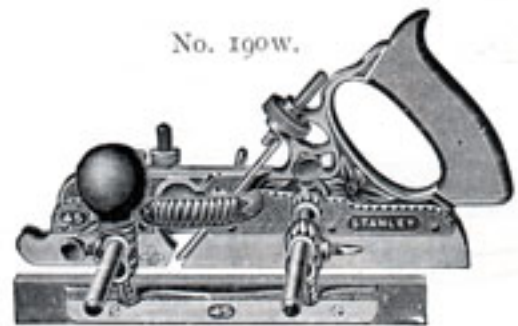
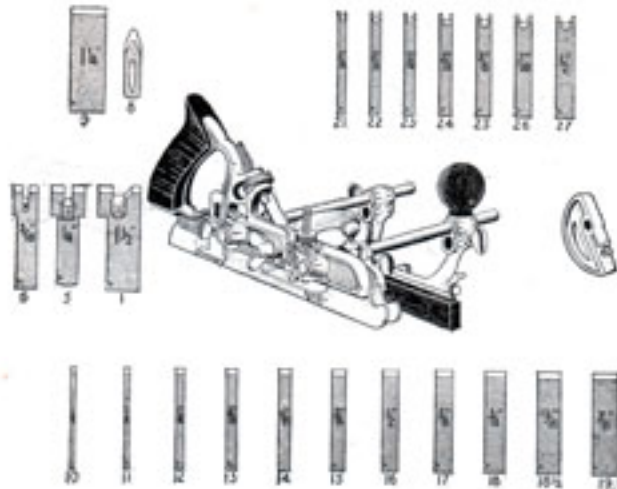

Price complete with 23 cutters £2 : 16 : 9

STANLEY "FORTY-FIVE" PLANE

Seven tools in one in compact and practical form. 1. Beading and Centre Beading Plane. 2. Plough. 3. Dado. 4. Rebate and Fillister. 5. Match Plane. 6. Sash Plane. 7. Slitting Plane. The Plane is fitted with spurs for use across the grain, and can be used either right or left hand. With each Plane are furnished twenty-three cutters, all of which are shown. The cutters, together with the Plane, are packed in a neat, substantial box. All metal parts are nickel-plated. The handle, knob, and adjusting fence are made of selected Rosewood.

CUTTERS REGULARLY SUPPLIED WITH PLANE

The following cutters are furnished with each Plane. The price is given in case duplicates should be required.

No.	Size.	Style.	Each.	No.	Size.	Style.	Each.	No.	Size.	Style.	Each.
1.	1 1/2 in.	Sash Tool	4/3	13.	1/2 in.	Plough and Dado Tool	1/3	21.	1/2 in.	Beading Tool	1/3
5.	1/2 ..	Match Tool	4/3	14.	3/8 ..	" " " "	1/9	22.	3/8 ..	" " " "	1/3
6.	3/8 ..	" " " "	4/3	15.	1/4 ..	" " " "	1/9	23.	1/4 ..	" " " "	1/3
8.		Slitting Tool	2/6	16.	1/4 ..	" " " "	1/9	24.	1/4 ..	" " " "	1/9
9.	1 1/2 in.	Fillister	2/-	17.	" "	" " " "	1/9	25.	3/8 ..	" " " "	1/9
10.	1/2 ..	Plough and Dado Tool	1/3	18.	" "	" " " "	1/9	26.	1/2 ..	" " " "	2/-
11.	3/8 ..	" " " "	1/3	18 1/2.	1/2 ..	" " " "	2/-	27.	1/2 ..	" " " "	2/-
12.	1/4 ..	" " " "	1/3	19.	3/8 ..	" " " "	2/-				

SPECIAL CUTTERS FOR "FORTY-FIVE" PLANE

These cutters are carried in stock and may be ordered by specifying the number of the cutter.

No.	Size.	Style.	Each.	No.	Size.	Style.	Each.	No.	Size.	Style.	Each.
2.	1 1/2 in.	Sash Tool	4/3	36.	1/2 in.	Fluting Tool	2/6	223.	3/8 in.	Reeding Tool, 3 Beads	2/6
28.	1/2 ..	Beading Tool	2/6	37.	3/8 ..	" " " "	2/6	224.	1/8 ..	" " " "	3/3
29.	3/8 ..	" " " "	2/6	38.	1/4 ..	" " " "	2/6	225.	3/16 ..	" " " "	4/3
31.	3/8 ..	Fluting Tool	2/6	212.	1/2 ..	Reeding Tool, 2 Beads	1/9	232.	1/2 ..	" " " "	1/9
32.	1/2 ..	" " " "	2/6	213.	3/8 ..	" " " "	2/6	233.	3/4 ..	" " " "	2/6
33.	3/8 ..	" " " "	2/6	214.	1/2 ..	" " " "	3/3	234.	1/2 ..	" " " "	3/3
34.	1/2 ..	" " " "	2/6	215.	3/4 ..	" " " "	4/3	235.	3/4 ..	" " " "	4/3
35.	3/8 ..	" " " "	2/6	222.	1/2 ..	" " " "	1/9				

SPECIAL BOTTOMS FOR "FORTY-FIVE PLANE"

To work Hollows and Rounds or a Nosing Cutter in the No. 45 Plane specially formed bottoms are furnished, called Hollows, Rounds, or Nosing Tool. A Hollow and its Cutter will form a Round. A Round and its Cutter will form a Hollow. A Nosing Tool and its Cutter will form what might be called an Exaggerated Round, as in shaping the edges of stair treads. Hollows and Rounds are made and sold in four sizes or sets, each set comprising 1 Hollow, 1 Round, and 2 Cutters. A Nosing Tool includes 1 Cutter.

No. 6.	Hollow and Round, 1/4 in. cutter	price 8/6 per pair.
" 8.	" " " "	" 8/6 "
" 10.	" " " "	" 9/6 "
" 12.	" " " "	" 9/6 "
" 5.	Nosing Tool, 1 1/2 in. cutter	7/- each.

UNIVERSAL COMBINATION PLANE

A THOROUGHLY GOOD TOOL EXTENSIVELY ADOPTED BY PRACTICAL WORKMEN

No. 191W.

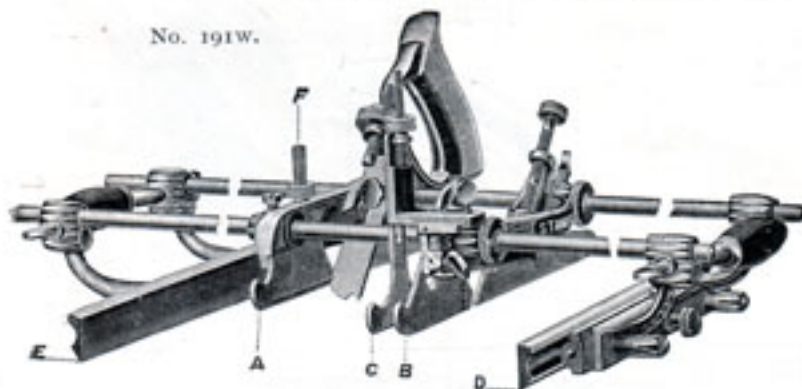

STANLEY "FIFTY-FIVE" PLANE

This Tool, in addition to being a beading and centre beading plane, a plough, dado, rebate, fillister, and match plane, a sash plane and a slitting plane, is also a superior moulding plane, and will accommodate cutters of almost any shape and size. In fact, it is "A PLANING MILL WITHIN ITSELF."

The regular equipment sent with the Plane comprises fifty-five cutters, all of which are shown. These cutters, together with the Plane and all its attachments, are packed in a neat, substantial box.

A further line of forty-one cutters are carried in stock. Cutters of practically any form can be used in the Plane, which the owner can make from blanks or order from sketch.

All metal parts of the Plane are nickel-plated. The handle and fences are made of selected Rosewood, and every part is well finished.

This Plane consists of :

A MAIN STOCK (A) with two sets of transverse sliding arms, a depth gauge (F) adjusted by a screw, and a slitting cutter with stop.

A SLIDING SECTION (B) with a patent vertically adjustable bottom.

THE AUXILIARY CENTRE BOTTOM (C) is to be placed in front of the cutter, as an extra support or stop, when needed. This bottom is adjustable both vertically and laterally.

FENCES D AND E.—Fence D has a lateral adjustment by means of a screw, for extra fine work. The fences can be used on either side of the Plane, and the rosewood guides can be tilted to any desired angle, up to 45°, by loosening the screws on the face. Fence E can be reversed for centre beading wide boards.

AN ADJUSTABLE STOP to be used in beading the edges of matched boards is inserted on the left-hand side of sliding section (B).

By means of the patent adjustable bottom and the auxiliary centre bottom it is possible to use a cutter of practically any shape with this Plane.

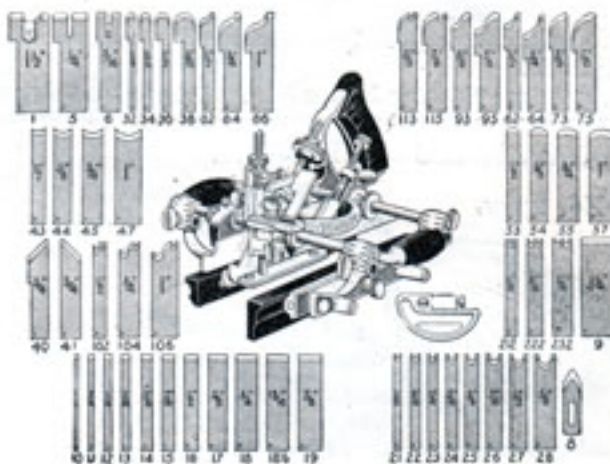
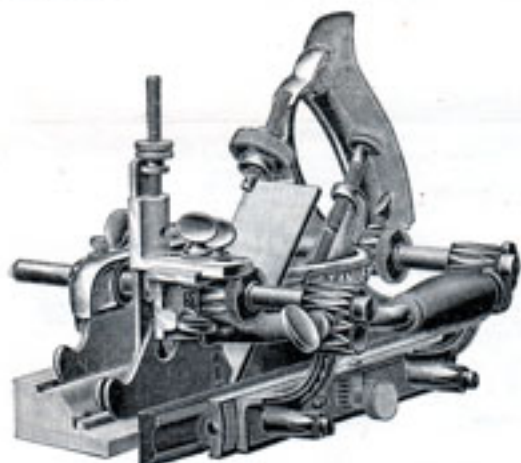

CUTTERS REGULARLY SUPPLIED WITH PLANE

The following Cutters are furnished with each Plane. The prices are given in case duplicates should be required :

No.	Description	Each.	No.	Description	Each.	No.	Description	Each.
1.	1 1/4 in. Sash Tool	4/3	25.	1/2 in. Beading Tool	1/9	62.	1/4 in. Quarter Hollow	3/9
5.	1/2 in. Match Tool	4/3	26.	1/4 in. Beading Tool	2/-	64.	" " " "	4/3
8.	Slitting Tool	2/6	27.	" " " "	2/-	73.	" " Round	3/9
9.	Fillister	2/-	28.	" " " "	2/6	75.	" " " "	4/3
10.	1/2 in. Plough and Dado Tool	1/3	29.	" " " "	2/6	82.	" " Reverse Ogee	3/9
11.	1/4 in. " " " "	1/3	32.	" " Fluting Tool	2/6	84.	" " " "	4/3
12.	1/4 in. " " " "	1/3	34.	" " " "	2/6	86.	" " " "	4/3
13.	1/4 in. " " " "	1/3	36.	" " " "	2/6	93.	" " Roman	3/9
14.	1/4 in. " " " "	1/9	38.	" " " "	2/6	95.	" " " "	4/3
15.	1/4 in. " " " "	1/9	40.	" " R.H. Chamfer	4/3	102.	" " Grecian	3/9
16.	1/4 in. " " " "	1/9	41.	" " L.H.	4/3	104.	" " " "	4/3
17.	1/4 in. " " " "	1/9	43.	" " Hollow	1/9	106.	" " " "	4/3
18.	1/4 in. " " " "	1/9	44.	" " " "	1/9	113.	" " 1/4 Rd. with Bead	3/9
18 1/2.	1/4 in. " " " "	2/-	45.	" " " "	1/9	115.	" " 1/2 in. " "	4/3
19.	1/4 in. " " " "	2/-	47.	" " " "	1/9	212.	" " Reeding Tool, 2 Bd.	1/9
21.	1/4 in. Beading Tool	1/3	53.	" " Round	1/9	222.	" " " " 2 " "	1/9
22.	1/4 in. " " " "	1/3	54.	" " " "	1/9	232.	" " " " 2 " "	1/9
23.	1/4 in. " " " "	1/3	55.	" " " "	1/9			
24.	1/4 in. " " " "	1/9	57.	" " " "	1/9			
Price complete						£5 : 11 : 6		

Bronze Medal 1884—Gold Medal 1890

IMPROVED IRON PLANES, English Manufacture

BULLNOSE REBATE

No. 192w.



Nickel-plated, with Rosewood Wedge, $3 \times \frac{3}{8}$ in.
Price 6/6 each.

BULLNOSE REBATE

No. 193w.



Japanned. Length, $3\frac{1}{2}$ in.; Cutting Iron, $1\frac{1}{2}$ in.
Price 7/6 each.

PATENT ADJUSTABLE BULLNOSE REBATE

No. 194w.

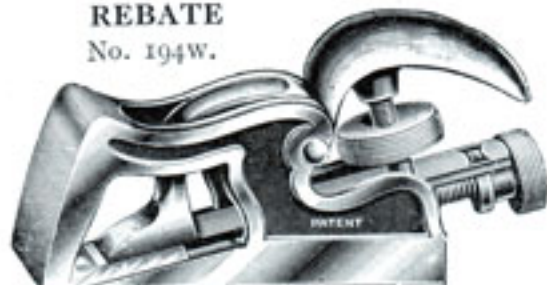

Nickel-plated. Quickly adjusted by means of knurled nut.
Length, 4 in.; Cutting Iron, $1\frac{1}{2}$ in. Price 12/6 each.

SHOULDER REBATE (Registered)

No. 195w.



Nickel-plated, Rosewood Wedge.
Length, 5 in.; Cutting Iron, $\frac{1}{2}$ in.
Price 12/6 each.

JAPANNED BULLNOSE

No. 196w.



Length, $3\frac{1}{2}$ in.; Cutting Iron, $1\frac{1}{2}$ in.
Price 8/6 each.

SHOULDER REBATE

No. 197w.



Adjustable. Nickel-plated.

Sizes	$5 \times \frac{1}{2}$	$8 \times \frac{3}{4}$	8×1	$8\frac{1}{2} \times 1\frac{1}{4}$	in.
Price...	...	14/6	26/-	29/-	30/-	each.

COMBINATION BULLNOSE AND FILLISTER PLANE

No. 198w.

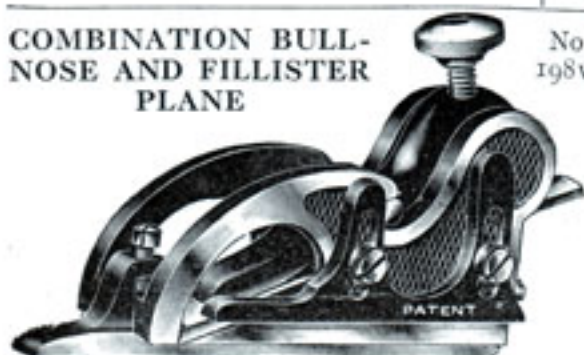

With Fence and Stop. Fence is attached to bed of Plane and is adjustable for varying depths of rebate. Both may be detached. Japanned.
Length, $3\frac{1}{2}$ in.; Cutting Iron, $1\frac{1}{4}$ in. Price 11/6 each.

ADJUSTABLE SIDE REBATE

No. 100w.

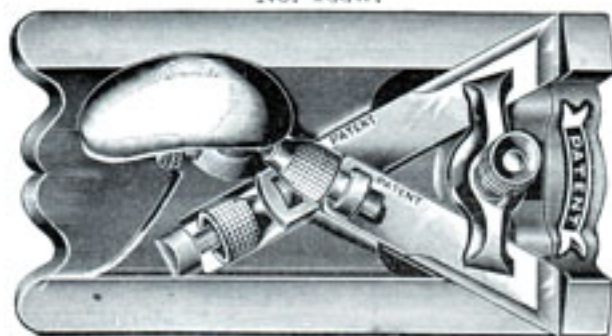

With right- and left-hand Cutting Irons. Nickel-plated. Price 17/6 each.

TOOL AND MACHINE MERCHANTS

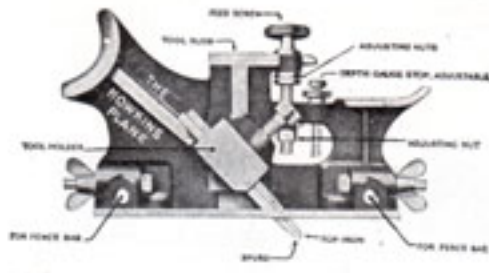

HOWKIN'S PATENT COMBINATION PLANE

No. 200W.

Highest Class English Manufacture in Gunmetal and Steel.

Price complete **£5 : 0 : 0**

Simple pattern in Iron and Steel **35/-**

The illustration gives some idea of the Plane's capacity, and the whole of the work shown can be executed by the

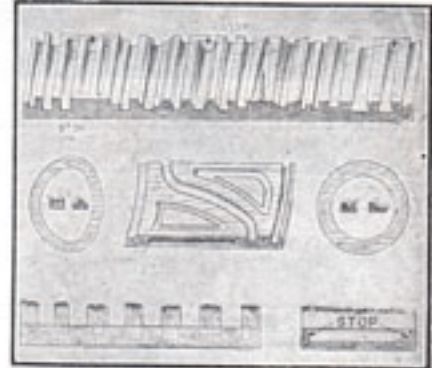

standard outfit—in some instances by changing the tools—with the exception that in the case of the larger radii, longer fence bars would be necessary.

The tools are fed down and find their own way into the work, straight through or to a self-formed stop at either or both ends; this applies to straight or circular work, etc., the grain of the wood making no difference.

A Reeding Tool for working with the grain is included but not illustrated.

A full descriptive Booklet sent on application.

NEW IMPROVED MITRE AND TENONING MACHINE

Indispensable for joiners, cabinet makers, etc.

No. 200W/1.

Illustration showing Machine set for Tenoning.

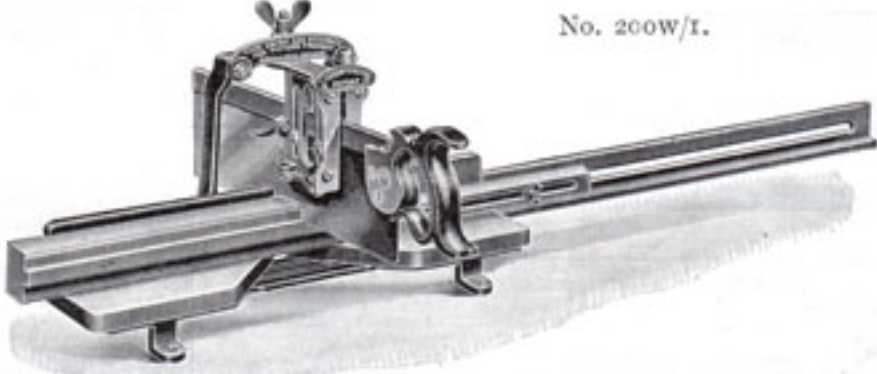

The machine is as necessary for the woodworker as it is for the picture framer, and should be in every workshop as a time saver.

This Machine has not only been designed for mitreing—it can be instantly set to cut square or any angle. For tenoning—an adjustable stop in the slotted side gauges the depth of the cut.

All the tenoning and checking required in window making can be done, rails and astrigals being cut to exact duplicate lengths without marking off. Facings, batten rods, etc., can all be cut and mitred a perfect job. Door mouldings mitred, etc.

A Machine like this is invaluable on an outside job for mitreing architraves, facings, mouldings, etc.

In Shop Fitting, where turned balusters, cornice mouldings, and general small fittings require accurate cutting, angle or square, a man can get through the work speedily and have a great pleasure using the Machine. It will have saved its price many times over at the finish of the job.

Cabinet makers with so much small tenoning and square cutting, etc., find the Machine a great saver.

Any woodworker can see at a glance that outside of mitreing altogether the Machine is indispensable and will pay itself in a few days' use. Any novice can make perfect work using this machine.

The framework and guide are rigidly built of malleable castings, with nothing liable to break or get out of order.

Price complete **£3 : 15 : 0**

SHUTEING BOARD AND PLANE

For pattern makers, cabinet makers, and picture framers. Amateurs will also find this tool very useful. The Board is of ribbed construction, and has an adjustable runway, accurately machined for the Plane. The swivel can be locked at any angle between zero and 90°. The swivel is fitted with a sliding back supporting the work to the edge, and with a sliding back clamp to hold any shaped work in position. The Plane is especially constructed for the Board, and has Rosewood handle and knob. The cutter has adjustment for depth of cut, also a lateral adjustment, so that a cut giving any ordinary draft to a pattern can be made.

No. 200W/2.

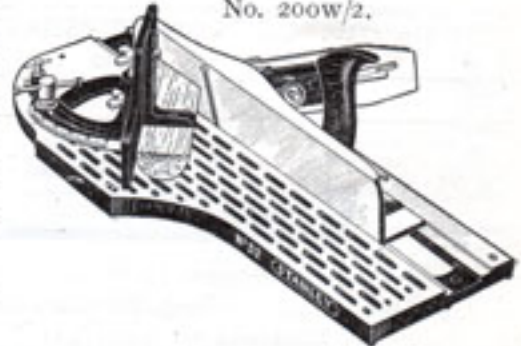

Length of Board, 22 in. ; length of Plane, 15 in. ; size of cutter, 2½ in.

Price complete **£3 : 13 : 9**

Builders' and Furnishing Ironmongery

FINEST QUALITY PLANE IRONS—Fully Warranted

MANUFACTURED FROM SHEFFIELD'S BEST CAST STEEL.

No. 201w.



SINGLE

No. 202w.



DOUBLE

No. 203w.



TOOTHING

Size	1½	1¾	2	2¼	2½	2¾	3	3½	4	in.
C.S. Single Cut Irons	-11	-11	1/2	1/3	1/4	1/6	1/7	1/9	2/-	ea.
.. Double ..	1/9½	1/11	2/1	2/2	2/5	2/8	2/11	3/2	3/5	..
.. Single .. Parallel	1/3	1/4	1/6	1/7	1/8	1/10	1/11	2/1	2/3	..
.. Double ..	2/2	2/3	2/5	2/6	2/9	3/-	3/3	3/6	3/9	..

C.S. Tothing, Fine or Medium, 2 in. wide. Price 1/8 each.

No. 204w.

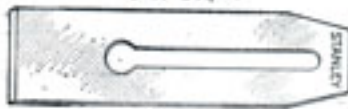

SINGLE

STANLEY PLANE IRONS

Size	1½	1¾	2	2¼	2½	2¾	3	3½	in.
Single	1/9½	2/-	2/3	2/6	2/9	2/11	3/2	ea.	
Double	2/11	3/2	3/5	3/7	3/10	4/-	4/6	5/-	..

No. 205w.

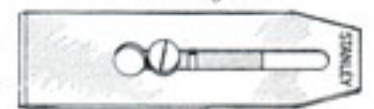

DOUBLE

TONGUING AND GROOVING

No. 206w.



From ¾ to 1 in. ... 2/- per pair.

BEST PLOUGH BIT

No. 207w.



½, ⅝, 1, 1¼, 1½, 1¾, 2, 2¼, 2½, 2¾, 3, 3½ in. 1/2 each.
The set, 8/6 each.

BEAD

No. 208w.

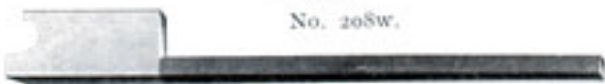

To ¼ in., 1/5 ½ in., 1/6 1 in., 1/10 each.

SOFT MOULDING

No. 209w.



To 1 in., -8 1½ in., -9 2 in., -10

No. 210w. **REBATE** Skew or Square.



To 1 1½ 1¾ 2 in.
Price ... -8 -9 -10 -11 1/- each.

HOLLOW AND ROUND

No. 211w.

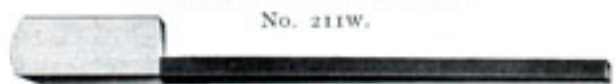

To No. 12, 2/3; to No. 18, 2/6 per pair.

BRIGHT SHOULDER

No. 212w.



To 1½ in., 1/1 1¾ in., 1/2 each.

BRIGHT BULLNOSE

No. 214w.

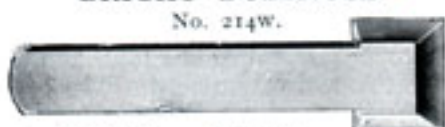

To 1½ in ... 1/- each.

No. 213w. **SPOKESHAVE IRONS**



All sizes to ... 2½ 3 3½ in.
Price ... -5 -6 -7 each.

Inquiries solicited for the following:
Machine, Paper Cutting, Circular, Guillotine,
Bookbinders' Knives, etc.



TECHNICAL BOOKS



No. 217W.
**GUIDE TO POKER-
WORK**
By W. D. Thompson.
Sixth Edition.
Price 1/2.

No. 215W.
RUSTIC CARPENTRY. With 194 Engravings and Diagrams.
1/8 post free.
Light Rustic Work—Flower Stands, Vases, etc.—Tables, Chairs, and Seats—
Gates and Fences—Rosery Work—Porch—Swing Canopy Aviary—Footbridges—
Verandahs—Tool Houses—Garden Shelters, etc.—Summer Houses—Dovecot—
Index.

No. 216W.
WOOD FINISHING. Comprising Staining, Varnishing, and
Polishing. New and Revised Edition. With 12 Engravings
and Diagrams. 1/8 post free.

Processes of Finishing Wood—Stains and Staining—Wood Grain Fillers and
Filling-in—Hard Stopping or Beausontage—French Polishing—Bodying-in and
Spiriting-off—Glazing in French Polishing: Some Special Matters—Wax Polishing
—Oil Polishing and Dry Shining—Repolishing and Reviving—Processes of
Varnishing Wood—Varnishes—Treatment of Floors—Dyeing Veneers—Marqueterie
Wood Staining—Spirit Enamelling with French Polish Finish—Index.

No. 218W.
BASKET WORK OF ALL KINDS. With 189 Engravings
and Diagrams. 1/8 post free.
Tools and Materials—Simple Baskets—Grocers' Square Baskets—Round
Baskets—Oval Baskets—Flat Fruit Baskets—Wicker Elbow Chairs—Basket
Bottle Casings—Doctors' and Chemists' Baskets—Fancy Baskets—Sussex Trug
Basket—Miscellaneous Basket Work—Index.



No. 219W.
**GUIDE TO CHIP CARV-
ING AS A RECREATION**
By W. Jackson-Smith.
Fifth Edition.
Price 1/2.

No. 220W.
PRINCIPLES OF CARPENTRY. By J. T. Hurst,
C.E., Mem. Soc. Eng., Mem. Phys. Soc. London. Twelfth
Edition. 584 pp., 198 Illustrations. 7/10 post free.

Preface—Introduction—Equality and Distribution of Forces—Resistance
of Timber—Construction of Floors, Roofs, Domes, or Cupolas—Partitions—
Scaffolds, Staging, and Gantries—Construction of Centres for Bridges—
Coffer Dams, Shoring and Strutting—Wooden Bridges and Viaducts—Joints,
Straps, and other Fastenings—Timber—Tables—Index.

No. 222W.
SPONS' MECHANIC'S OWN BOOK. A Manual for
Handicraftsmen and Amateurs. Seventh Edition. 702 pp.
1,430 Illustrations. 7/10 post free.

Mechanical Drawing—Casting and Founding in Iron, Brass, Bronze, and
other Alloys—Forging and Finishing Iron—Sheet Metal Working—Soldering,
Brazing, and Burning—Carpentry and Joinery, embracing descriptions of
some 400 woods—Over 200 Illustrations of Tools and their Uses—Explanations
(with Diagrams) of 116 Joints and Hinges, and Details of Construction
of Workshop Appliances—Rough Furniture, Garden and Yard Erections,
and House Buildings—Cabinet Making and Veneering—Carving and Fret
Cutting—Upholstery—Painting, Graining, and Marbling—Staining Furniture,
Woods, Floors, and Fittings—Gilding, Dead and Bright, on various Grounds—
Polishing Marble, Metals, and Wood—Varnishing—Mechanical Movements,
illustrating contrivances for transmitting Motion—Turning in Wood.

No. 223W.
BOOT MAKING AND MENDING. Including Repairing,
Lasting, and Finishing. With 179 Engravings and Diagrams.
1/8 post free.

Repairing Heels and Half-soleing—Patching Boots and Shoes—Re-welting
and Re-soleing—Boot Making—Lasting the Upper—Sewing and Stitching—
Making the Heel—Knifing and Finishing—Making Riveted Boots and Shoes
—Index.

No. 224W.
BOOKBINDING. With 125 Engravings and Diagrams.
1/8 post free.

Bookbinders' Appliances—Folding Printed Book Sheets—Beating and
Sewing—Rounding, Backing, and Cover Cutting—Cutting Book Edges—
Covering Books—Cloth-bound Books, Pamphlets, etc.—Account Books,
Ledgers, etc.—Colouring, Sprinkling, and Marbling Book Edges—Gilding Book
Edges—Sprinkling and Marbling Book Covers—Lettering, Gilding, and
Finishing Book Covers—Index.

No. 225W.
THE CLERK OF WORKS. A Vade-mecum for all
engaged in the superintendence of Building Operations.
By the late G. G. Hoskins, F.R.I.B.A. Revised and
enlarged by H. P. Hoskins, L.R.I.B.A. Eighth Edition.
64 pp. 2/10 post free.

No. 226W.
WOOD TURNER'S HANDYBOOK. A Practical Manual
for Workers at the Lathe. By Paul N. Hasluck. Author
of *Lathe Work*, etc. 144 pp. With 100 Illustrations.
2/9 post free.

"We recommend the book to young turners and amateurs."—*Mechanical
World*.

No. 227W.
POKERWORK DESIGNS. 4 Sheets. 1/—.

No. 228W.
MARQUETERIE DESIGNS. 4 Sheets. 1/—.
Series 1, 3, and 4.

No. 221W.
BUILDING CONSTRUCTION DRAWING. A Class-
book for the Elementary Student and Artisan. By R. B.
Eaton, Lecturer on Building Construction.

Part I.—26 plates, 59 pp. 2/4 post free.

Specifications and Dimensioned Drawings for the following: Brickwork—
Ground Floor—First Floor—Roof, etc.—Entrance Doorway—Window (Sash
Frame)—Window (Casement)—Internal Doors and Linings—Stairs—Entrance
Doorway.

Part II.—26 plates, 64 pp. 2/4 post free.

Specifications and Dimensioned Drawings for the following: Bay Window
—Sashes and Frames—Gable over ditto—Roof over Bay Window—Dormer
Window—Dormer Window with Curved Top—Porch to Entrance Doorway—
Entrance Doorway—Bay Window—Staircase.

Part III.—25 plates, 80 pp. 2/4 post free.

Plans, Elevations, Sections, and Details of the following: Mansard Roof
Truss—Octagonal Tower—Circular Tower—Bay Window—Lantern Light—
—Window with Stone Dressing—Small House—Bungalow—Entrance Porch—
Straight Sewer Manhole—Villa Residence—Windows—Bay Windows—
Staircase. Specification of Villa Residence.

Part IV.—Joinery Drawings, Specifications, and Measure-
ments. 88 pp., 24 plates. 2/4 post free.

Specifications, Dimensions, Details of, and Materials for the following:
Sections of Door Jambs—Setting out for Door Frame—Lagged and Braced
Door and Frame—Framed, Lagged, and Braced Door and Frame—Framed,
Lagged, and Braced Door and Frame, with Fanlight—Pair of Yard Gates—
Front Entrance Door and Frame, with Segmental Head and Fanlight—
Front Entrance Door and Frame—Entrance Door and Frame, with Fanlight
and Side-lights—Entrance Doors and Frame with Elliptical-shaped Head,
Doors hung Folding—Entrance Doorway and Side-lights—Framed and
Panelled Doors—Joints of a Framed and Panelled Door—Ten Internal Door
Linings—Internal Door and Linings—Pair of Swing Doors hung on Patent
Brass-cased Steel Spring Hinges.

Part V.—Joinery Drawings, Specifications, and Measure-
ments. 96 pp., 26 plates. 2/4 post free.

Specifications, Dimensions, Details of, and Materials for the following:
Cased Frame and 2 in. Sashes, Double Hung—Deal-cased Sash Frame with
2 in. Sashes—Cased Frames and Sashes, with Semicircular and Segmental
Heads—Joints of Sashes with Semicircular Head—Sash Frame with Semi-
circular Head; Joints; Alternative Methods—Cased Frame and 2 in. Sashes
with 2 in. Fanlight over—Cased Bay Window Frame with Mullion—Case-
ments and Frame, 5 x 4 in. Frame, 2 in. Sashes—Angle Casement Window—
Bay Window—Plan of Staircase with Close Strings, Elevations at first, second,
and third Flights.

Part VI.—Joinery Drawings, Specifications, and Measure-
ments. 76 pp., 30 plates. 2/4 post free.

Specification and Dimensioned Drawings for the following: Skirtings—
Picture and Chair Rails—Architraves—Casement Frame with Pivot-hung
Sashes—Skylight—Lantern Light with Flat Top—Lantern Light—Octagonal
Lantern Light—Panelling to Dining-room—Kitchen Dresser—Kitchen
Dresser with Glazed Doors—Sideboard with Cupboard over—Porch to Entrance
—Hood over Front Door—Hood over Front Door with Curved Top.

The object of this work is to provide the Building Construction Student
and those connected with the Building Trade with a graduated set of draw-
ings which will help them to acquire a knowledge of drawing and also of
the simpler forms of Building Construction. The drawings are chiefly those
of work which the ordinary student will meet day by day, and short specifica-
tions have been prefixed to many of them.

The six parts bound together in one volume, 13/— post free.

CABINET AND BOX SCRAPERS

**DOUBLE HANDLE—ROLLER
BOTTOM** No. 229w.

This Scraper has a roller at the back of the blade which acts as a support to relieve the strain on the wrists of the workman. Handle is made of Beech and can be detached for working into corners.



9½ in. long, 4 in. blade. Nickelled, 6/6 each.

**DOUBLE HANDLE—ROSEWOOD
BOTTOM** No. 230w.

This Scraper has a Rosewood bottom for use in the finest cabinet work. The handles are raised to protect the hands, and pierced so that it can be hung up out of the way.



10 in. long, 2½ in. blade. Nickelled, 8/9 each.
Extra Iron, 1/3

**DOUBLE HANDLE—IRON
BOTTOM** No. 231w.

The blade may be sprung to a slight curve by means of a thumb screw, giving ease of operation and quickness of cut. The handles are raised to protect the user's hands, and pierced so that the tool can be hung up out of the way.



11 in. long, 2½ in. blade. Japanned, 4/6 each.
Extra Iron, 1/3

SINGLE HANDLE—ADJUSTABLE
No. 232w.

This Scraper has an adjustable single handle which can be tilted to give the blade any angle desired. Special blades of different forms and widths can be securely held in any position required, thus permitting the tool to be worked in many places inaccessible to other Scrapers. Handle and knob of Hardwood.



14½ in. long, 3 in. blade. Japanned, each 7/3 Extra Iron, 1/1

**DOUBLE HANDLE SCRAPER
PLANES** No. 233w.

The handles are of Rosewood with a double grip, and being placed across the centre of the tool, give it a good balance. The blades are adjustable endwise and for angle, and can be firmly locked in position desired.



6½ in. long, 3 in. blade. Japanned, 16/8 each.
Extra Cutter, 2/-

BOX SCRAPER No. 234w.

For removing stencils and other markings from the surface of boxes, floors, etc. The handle is hinged above the surface. The face of the bottom and the edge of the cutter are slightly curved away from the centre, allowing the user to scrape clean any uneven surface. Handle is made of Maple.



13 in. long, 2 in. blade. Japanned, 4/- each.
Extra cutter, -/10½

**CABINET MAKER'S SCRAPER
PLANE** No. 235w.

In working, the blade springs backward, opening the mouth and allowing the shaving to pass through it. As soon as working pressure is released the blade springs back to its normal position. Handle and knob are pivoted, to allow tilting for convenience when working into corners or up against perpendicular surfaces.



8 in. long, 2 in. blade. Japanned, 17/- each.
Extra Iron, 2/-

SCRUB PLANES No. 236w.

For planing down to a rough dimension any board that is too wide to conveniently rip with a hand saw, an operation that is sometimes called "hogging." This is made possible by reason of the peculiar shape of the extra heavy cutter, the cutting edge of which is round instead of square. Handle and knob of Beech.



9½ in. long, 1½ in. cutter. Japanned 9/3 each.
10½ " " " " " " 12/3
" " Extra Iron, -/10 and 1/1 each.

**SINGLE HANDLE SCRAPER
PLANES** No. 237w.

The handle and knob have the same form as the regular "Bailey" Plane, being preferred by some users to the two-handle or double grip form of Scraper Plane. The blades are adjustable endwise and for angle, and can be firmly locked in position desired.



9 in. long, 3 in. blade. Japanned, 16/3 each.
Extra Cutter, 2/-

JOINERS' SCRAPER BLADES

No. 238w.

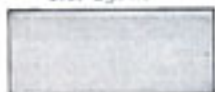

Oblong.

Size 4 5 6 in.
Price -/5 -/6 -/7 ea.

No. 239w.



Curved.

Price ... 1/- ea.

No. 240w.



Concave and Convex.

Size 4 x 2½ 5½ x 2½ in.
Price -/9 -/10 ea.

HANDLED SCRAPER SHARPENER

No. 241w.



Price 1/- each.

CABINET SCRAPER

No. 242w. Complete, with Hardwood handle and wedge.
Price 3/6 each.

**HANDLED CABINET
SCRAPER**



No. 243w.
Blade removable.

Price complete,
2/- each.

CORNERING TOOL

No. 244w.
For rounding sharp edges. These have a different size cutter at each end, and their form is such that no depth gauge is required. 5½ in. long.



No. A. ¼ and ½ in. cutter ... price 1/6 each.
" B. ½ " ½ " " " " 1/8 "

Bronze Medal 1884—Gold Medal 1890

TOOL AND MACHINE MERCHANTS

COACHMAKERS' ROUTERS

JIGGER OR SIDE ROUTER

No. 245w.



Price 26/- each.

FENCE OR GROOVING ROUTER

London Pattern.

No. 246w.



Price 35/- per pair.



BEADING ROUTER

No. 247w.



Price ... 18/- each.

PISTOL ROUTER

No. 248w.



Price 34/- per pair.

BOXING ROUTER

No. 249w.



Price, with Iron ... 8/- each.
 $\frac{1}{2}$, $\frac{3}{8}$, or $\frac{1}{4}$ in.

ADJUSTABLE IRON GROOVING OR DEPTHING ROUTER, NICKEL-PLATED

Drawn about Quarter Size. No. 250w.

For smoothing the bottoms of grooves or cavities below the surface. Two Cutting Irons (one $\frac{1}{8}$ in. and one $\frac{1}{16}$ in.) are supplied with each tool. These are held in position on the upright grooved supports by means of the collar and milled head screw. They may be used in the position shown in Fig. 1, or fixed and used in the groove on reverse side of centre support. For working close into corners either of the knobs may be removed and the cutting iron fixed on one of the end supports as shown in Fig. 2.

The cutting irons may be adjusted by milled nut to the various depths required. When adjusting cutting iron, slacken milled head screw of collar.
 Price ... 16/6 each.



FIG. 1.



FIG. 2.



GROOVING OR DEPTHING ROUTER

Drawn Half Size. No. 251w.

For smoothing the bottoms of grooves and depressions below the surface of small woodwork. The cutting irons may be used in the centre as shown, or either knob may be removed and cutting iron inserted for getting close into corners.

Price 7/6 each.

MALLEABLE IRON SMOOTH PLANE FRONTS



No. 252w.

With Screw and Cup.

Size $2\frac{1}{2}$ $2\frac{1}{2}$ in.
 Price $\frac{4}{3}$ $\frac{4}{3}$ each.
 Size $2\frac{1}{2}$ $2\frac{1}{2}$ in.
 Price $\frac{4}{3}$ $\frac{4}{3}$ each.

GUN-METAL LEVERS

With screws at side. Bright polished.



No. 253w.

Width 2 $2\frac{1}{2}$ $2\frac{1}{2}$ in.
 Price 5/- 5/- 5/- ea.
 Width $2\frac{1}{2}$ $2\frac{1}{2}$ in.
 Price... $\frac{5}{6}$ $\frac{5}{9}$ ea.

PLANE STOPS, Etc.

No. 254w.

Fillister, left hand, as shown, 4/6 each.



Moving Fillister Stop, $\frac{2}{3}$ each.
 Plough Stop, each 4/6

BEECH CARVER'S ROUTER

No. 255w.

Size, 4 in.

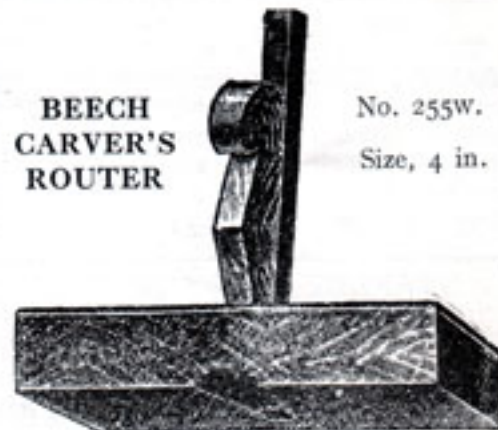

Price $\frac{2}{3}$ each.

RICHARD MELHUISH LIMITED, LONDON, E.C.

PATENT ADJUSTMENT QUIRK ROUTER

No. 256w.

The Cutting Irons of the tool are readily adjusted by means of the milled nut; no hammer is required; by simply turning the nut the irons are adjusted to cut any desired depth.

The milled nut also acts as a stop, and prevents the Cutting Iron from being forced back when in use.

Complete with $\frac{3}{32}$, $\frac{1}{8}$, $\frac{3}{16}$ in. Cutters 14/-



IMPROVED CIRCULAR GROOVING ROUTER

No. 257w.



This is a similar tool to the above, but without the adjustment to the Cutting Irons.

Price 11/- complete.

IMPROVED CIRCULAR REBATING AND FILLISTER ROUTER

No. 258w.



This tool is an accompaniment to the Sash Router, and has one cutting iron and two pairs of adjustable fences, and can thus be employed as a Rebating or Moving Fillister Router. The fences are adjusted for working out the rebate on various thicknesses by means of a groove along which they slide, being firmly fastened by a screw. Fences are adjustable from $\frac{1}{8}$ to $\frac{3}{4}$ in.

Price 7/- complete.



IMPROVED PATENT HAND REEDING AND MOULDING TOOL

No. 259w.

This is the most improved form of Reeding and Moulding Tool yet produced. It is nicely finished, and a milled nut is provided for the exact adjustment of the iron. Three Fences—concave, convex, and straight—are included. Six Cutters, as illustrated, are supplied with each tool.

Price 13/- complete.

No. 260w. As above, without adjustment for the Cutting Irons.

Price 12/- complete.

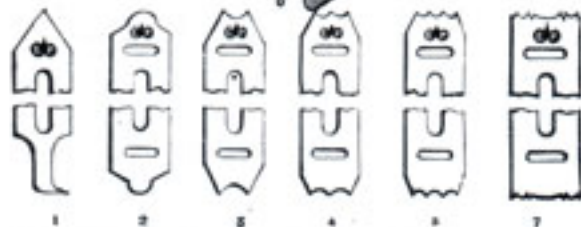

REEDING, REBATING, AND MOULDING TOOL

No. 261w.

This will be found a most useful small hand tool for Reeding and Moulding. Six cutters are sent, as shown, with each tool. No. 1 forms a Cutting Gauge and Grooving Tool; No. 2, Round; No. 3, Hollow; Nos. 4 and 5 are adapted for Rebating Picture Frames, etc.; No. 5 is also useful for Chamfering; also useful for Fretworkers and Wood Carvers; No. 6 is for forming Mouldings.

With 6 Steel Cutters as drawn price 5/- each.



STANLEY HAND BEADER

No. 262w.



With each Bearer are furnished a square gauge for straight work and an oval gauge for curved work. Also the following eight cutters sharpened at both ends: 6 single beads, $\frac{1}{8}$, $\frac{3}{16}$, $\frac{1}{4}$, $\frac{5}{16}$, $\frac{3}{8}$, and $\frac{1}{2}$ in.; 2 fluting tools, $\frac{3}{16}$ and $\frac{1}{4}$ in.; 4 reeding tools (2 beads $\frac{3}{16}$ in., 3 beads $\frac{1}{4}$ in., 3 beads $\frac{1}{2}$ in., and 4 beads $\frac{1}{2}$ in.); 2 routers, $\frac{1}{8}$ and $\frac{1}{4}$ in.; and a $\frac{3}{8}$ in. blank.

Length, 11 $\frac{1}{2}$ in. price 6/9 each.

Builders' and Furnishing Ironmongery

IRON SPOKESHAVES

ROUND FACE

No. 263w.

These are nicely finished, nickel-plated, and will be found very useful for working in small circles.

A size, 1 in. Iron, 2/3 each. B size, 1 1/2 in. Iron, 3/6 each.



No. 264w.



Japanned. Length, 10 in. 2 in. Cutter.

Price, 2/- Extra Cutters, -/7

No. 265w.



Flat face. Adjustable. Length, 10 in. 2 in. Cutter.

Japanned, 5/6 Nickel-plated, 6/6

Round faced ditto, same prices.

Extra Cutters, 1/3 each.

PATENT ADJUSTABLE STOP CHAMFER SHAVE

No. 266w.



With Patent Adjustment to Cutting Iron.

This tool makes its own stop. This is a great advantage, as both the chamfer and stop are made at the same time, thus dispensing with the use of the chisel.

Price 8/6 each.

IMPROVED CIRCULAR SASH ROUTERS

No. 267w.



This is available to work either right or left. It has 2 cutting irons, and is made in the following sizes, viz. 1/2, 3/4, and 1 in., to work either lamb-tongue or ovolo sashes, and can be constructed to work with any plane maker's pattern mouldings.

Either Pattern. Price 8/- each.

OVOLO ROUTER

No. 268w.



Size	1/2	3/4	1	in.
Price	8/-	8/6	9/6	each.

CIRCULAR BEAD ROUTER

No. 269w.



Size...	...	1/4	3/8	1/2	3/4	1	in.
Price	7/3	8/-	8/-	8/6	8/6	each.

PATENT LINING OR STRINGING ROUTERS

No. 270w.



No. 271w.



This will be found a very useful tool to cabinet and pianoforte makers, fret and other woodworkers, for inlaying "strings" and "bands." The tool is sent with 6 cutters varying in width from 1/16 to 3/4 in. These are adjusted to the desired depth of cut by means of "Patent Adjustment." It has one fence which is movable and reversible to suit different sweeps of wood. On very cross-grained wood it would be preferable to gauge lines the width of the "band" before using the broad irons.

No. 271w is supplied with a round adjusting rod which is provided with two screwed holes and a removable pointed screw pin. This pin may be inserted in either hole and the rod adjusted according to desire. This combination will be found very useful when inlaying curves. When using the tool for curves, the fence should be entirely removed.

No. 270w. Price 7/6

No. 271w. Price 10/-

Cutting Irons, -/9 each extra.

Horticultural and Estate Appliances

RICHARD MELHUIH LIMITED, LONDON, E.C.

BEST QUALITY WOOD AND OTHER SPOKESHAVES

ROUND FACE BEECHWOOD

No. 272w.

Size ...	1½	1¾	2	in.
Price ...	1/6	1/6	1/6	each.



ROUND FACE BOXWOOD

No. 273w.

Size ...	1½	1¾	2	in.
Price ...	2/3	2/3	2/3	each.

BEST BEECH (Flat)

No. 274w.

Size 2½	2¾	3	3½	4	in.
Price 1/6	1/6	1/9	2/1	2/3	ea.



BEST BOXWOOD (Flat)

No. 275w.

Size ...	2½	3	4	in.
Price ...	2/3	2/9	3/6	each.



Front View.

The blades are quickly adjusted by means of two screws as shown.

NEW ADJUSTABLE PATTERN

No. 276w.

Price, in Beech
.. Box



Back View.

Size ...	2	2½	3	in.
Price ...	1/9	1/10	2/-	each.
.. ..	2/3	2/4	2/6	..



CIRCULAR SHAVE No. 277w.

Will work in smaller circle than any other Shave. Either handle can be removed to work in cramped places.

Price 5/9 each.

This Shave has a throat regulator which will present to the knife four faces; one flat, two oval or convex, and one concave. With either face a wide or narrow throat may be had.

Price 10/6 each.

IMPROVED FOUR-FACED SPOKESHAVE

No. 278w.



UNIVERSAL SHAVE

No. 279w.

Both handles are detachable, thus enabling the owner to work into corners or panels. It has two detachable bottoms, adapting it equally well to circular work or straight; and, by means of a movable width gauge, the tool can be used in rebating.

Price 7/9 each.

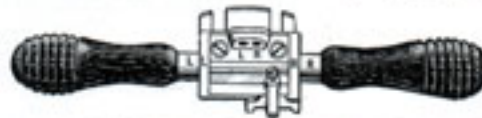

HOLLOW SHAVE

No. 280w.

Length, 10 in.; cutter, 2½ in.

Price 1/10 each.

Extra Iron, -/8 each.



No. 281w.

No. 51

Raised handle.

Length, 10 in.; width of cutter, 2½ in.

Price 1/10 each.

Extra Iron, -/8 each.



No. 282w.

Length, 10 in.; width of cutter, 2½ in.

This has adjustable mouth.

Price 2/4 each.

Extra Iron, -/8 each.



No. 283w.

Adjustable cutter, raised handles.

Length, 10 in.; cutter, 2½ in.

Price 2/7 each.

Extra Iron, -/8 each.

EXTRA LIGHT

No. 284w.

Designed especially for use in manual training schools, or for any work requiring the use of an extra light Spokeshave.



Straight handle, 9 in. long, 1½ in. cutter.

Price 1/6 each.

ADJUSTABLE CHAMFER

No. 285w.

A very convenient tool. Can be adjusted to work chamfers up to 1½ in. (the width of the cutter).



Raised handle, 9½ in. long, 1½ in. cutter.

Price 3/2 each.

STANLEY RAZOR EDGE No. 286w.

So called from the shape of the cutter, which is hollow ground, giving an exceptionally keen cutting edge. They have an adjustable front, which can be moved up or down, giving the same effect as if the cutter was raised or lowered.



Boxwood handles.

Length.	Cutter.	Price.
11 in.	2 in.	5/3 each.
12 ..	2½ ..	5/9 ..

IMPORTANT TO THOSE ORDERING THROUGH SHIPPERS.—In order to ensure getting complete satisfaction, we advise our friends to be careful in giving definite instructions that the goods shall be procured direct from our house. By this means you may be sure of receiving the patterns and quality specified in our Catalogues.—R. MELHUIH, LTD.

Electric and Wireless Engineers

TOOL AND MACHINE MERCHANTS

DRAW KNIVES

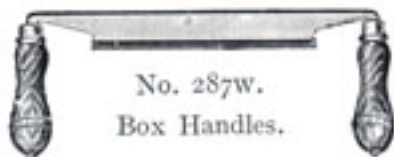

No. 287w.
Box Handles.

Size 5	6	7	in.
Best Cast Steel ...	3/9	4/3	4/6	each.

DRAW KNIVES



No. 288w.
Best Cast Steel,
Curved.

Length 8	9	10	in.
Price ...	3/9	4/3	4/6	each.

DRAW KNIVES

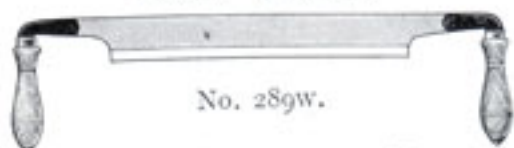

No. 289w.

Length ...	8	9	10	12	in.
Price ...	3/9	4/-	4/3	5/-	each.

DRAW KNIFE



No. 290w. Adjustable Handle.

Folds into small space, goes into hand tool case or shoulder chest; folded handles protect cutting edge. No slots to hurt the hands. Handles adjust to suit workman. Blades properly tempered, ground, and honed. Tangs extend through handles.

Length of Blade, 8 in.
Price 12/6 each.

CIRCULAR ALUMINIUM LEVEL

No. 291w.
For attaching to Steel Square or Rule. Handy for the pocket.
Diam., 1 1/4 in.



Price, in Case, 3/9 each.



BEST FIELD-SIGHT SURVEYING LEVEL

No. 294w.
With 10 in. Level.
Price 45/- each.

MOUNTED ON WOOD STAFF

No. 295w.
With 12 in. Level.
Price 49/6 each.

PATENT ADJUSTABLE PLUMB AND LEVEL



No. 292w.
In Mahogany.

Length, 3 ft. 6 in.
Width, 3 1/4 in.
Price 15/6 each.



LEAD PLUMB BOB
No. 293w.
Weight. Price.
1 lb. ... 10/- ea.
1 1/2 " ... 1/3 "
2 " ... 2/- "

BRASS BOB



No. 298w.
Weight. Price.
3 1/2 oz. ... 1/6 ea.
4 1/2 " ... 2/- "
8 " ... 3/- "
10 " ... 3/6 "
16 " ... 5/3 "
24 " ... 10/- "

JAPANNED IRON PLUMB BOB



No. 299w.
Price, Wt. each.
1/2 lb. 1/9
3/4 " 2/3
1 " 3/-
1 1/2 " 4/-
2 " 5/6

SURVEYING LEVEL

Mounted on Tripod Stand.
No. 296w.
With 10 in. Level, 90/- each.
No. 297w.
With 12 in. Level, 94/6 each.

Bronze Medal 1884—Gold Medal 1890

SPIRIT LEVELS—Warranted Correct

No. 300w.



Length ...	6	8	10	in.
No. Brass-plated top ...	1/3	1/7	2/-	each.
" " " tipped bottom	1/7	1/10	2/6	"

No. 302w.



Ebony, Brass-plated top, Brass tipped bottom.

Length ...	8	10	12	in.
Price ...	3/-	3/6	4/3	each.

No. 304w.



All Brass Mounted Level, with revolving protector, fitted over tube bulb. Complete with case.

Length ...	6	8	10	12	in.
Price ...	6/6	7/3	9/-	10/9	each.

IRON LEVEL

No. 306w.



With Brass top.

Length... ..	6	in.
Price	2/-	each.

ENGINEER'S SPIRIT LEVEL

No. 308w.



A very handy form of Iron Level with V-shaped base for standing on shafting and other round surfaces. It is accurately machined and highly finished, nickel-plated, and packed in velvet-lined case.

Length	4	6	in.
With Patent Cat's Eye Tubes	6/9	9/-	each.

BEST PROVED LEVEL TUBES

No. 312w.

Each one with proof mark.

Length ...	1	1 1/2	2	2 1/2	3	3 1/2	4	in.
Price ...	-7/4	-7/4	-7/4	-7/5	-7/5	-7/6	-7/8	ea.



CAT'S EYE LEVEL TUBES

No. 313w.

The bulb resembles a cat's eye, and is easily distinguished.

Length ...	1	1 1/2	2	2 1/2	3	3 1/2	4	in.
Price ...	-7/4	-7/4	-7/4	-7/5	-7/5	-7/6	-7/8	ea.

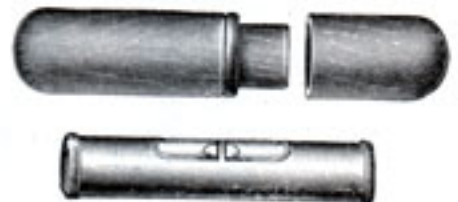

No. 301w.



Heavy Brass-plated top, tipped bottom.

Length ...	8	10	12	in.
Price ...	3/3	4/-	4/6	each.

No. 303w.



Ebony, extra quality, best plated.

Length ...	8	10	12	in.
Price ...	5/-	6/-	7/-	each.

No. 305w.



The Climax is machined and grooved on base for testing shafting, etc. The base is also improved for ordinary flat work. The lock nuts enable the level to be instantly adjusted.

Length... ..	6	8	in.
Price	8/3	9/6	each.

If with Plumb and Cross Levels, 12 in. only, 14/6 each.

IRON LEVEL

No. 307w.



With Brass top. Nickelled.

Length... ..	4	6	in.
Price	2/6	3/9	each.

No. 309w.

Iron, with grooved base for attaching to rule or square.



BRASS LEVEL

No. 310w.

Nickel-plated.
Length 2 1/2 3 1/2 in.
Price ... 1/9 2/2 each.



BRASS POCKET LEVEL

No. 311w.

Complete in Box-wood case.
Price ... 1/10 each.

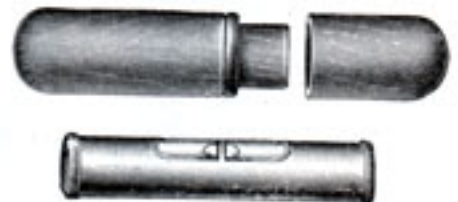

TOOL AND MACHINE MERCHANTS

PLUMB AND SPIRIT LEVELS—Warranted

No. 314W.



Rosewood, ornamental Brass-plated and tipped bottom.

	6	9	12	
	in.			
Price	3/3	3/9	4/6	each.

No. 315W. Without Plumb

Price	2/6	3/3	3/9	..
-------	-----	-----	-----	----

No. 316W.



MASON'S BOXWOOD RULE AND LEVEL

Tipped bottom and ends.

Length	6	9	12	
	in.						
Price	3/9	4/-	4/6	each.

PLUMB AND LEVEL. No. 318W.

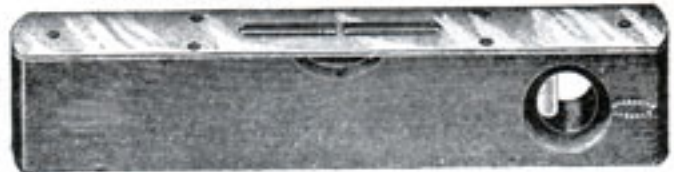

Polished, Brass-plated top.

Length	8	10	12	
	in.						
Price	3/3	4/-	4/6	each.

SPIRIT LEVEL REGISTERED DESIGN

No. 319W.



In this pattern the bubble tube is set in a special Brass frame with very large openings at the top and sides. These openings are fitted with glass panels, and enable the user to see the bubble very plainly and from a distance. The large side views are particularly useful for testing overhead work. This Level is also proved on the top, so that it can be used for testing overhead work from the top of the Level in places where it is not possible to place the Level on its base.

Price, in Mahogany, polished, Brass tipped top and bottom corners.	Length, 18 in.	14/-	each.
" " " not tipped.	Length, 18 in.	13/-	..

ADJUSTABLE PLUMB AND SPIRIT LEVELS. No. 320W.



Triple stock, beautifully polished. The bubble tube is set in a metallic case attached to the brass top plate of the Level. By means of an adjustable screw the tube can be instantly adjusted to a position parallel with the bottom of the Level. They are made of Rosewood and Mahogany and fitted with the best tested tubes. Length, 24 in., 18/- each. 30 in., 21/- each.

IMPROVED ADJUSTABLE MAHOGANY STOCK

Brass arch top plate, lip side views, and full Brass tipped. Length, 24 in., 13/6 each. 30 in., 15/- each.



No. 321W.

NON-ADJUSTABLE PLUMB AND SPIRIT LEVELS No. 322W.



These are made of selected Hardwood and are fitted with best tubes. The horizontal tubes are marked with two lines, the plumb tube one line.

Length	12	15	18	
	in.					
Price	4/6	4/9	5/-	each.

NEW PATTERN PLUMB AND LEVEL

No. 323W.

Hardwood stock, tipped bottom. Size, 3 in. deep x 1/2 in. wide. Length, 36 in. Price 9/6 each.



Builders' and Furnishing Ironmongery

BOXWOOD RULES

TWO-FOOT FOUR-FOLD
No. 324w.



Round joint, 1 in. wide. Marked 8ths and 16ths.
Price 1/- each.

TWO-FOOT FOUR-FOLD
No. 326w.

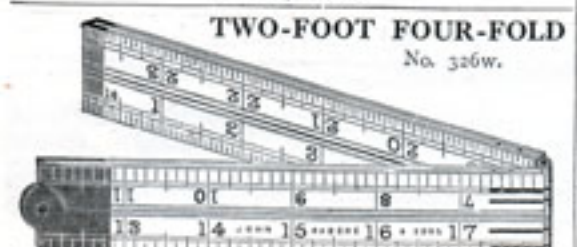

Square joint, 1 in. wide. Marked 8ths and 16ths.
Price 1/3 each.

TWO-FOOT FOUR-FOLD
No. 331w.

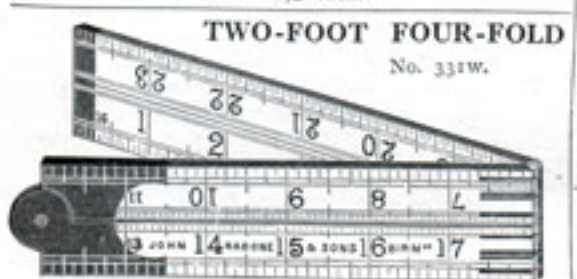

Marked 8ths, 10ths, 12ths, and 16ths.
Width... 1 in., 1 1/2 in., 1 3/4 in.
Price ... 1/6 ... 1/9 ... 2/- each.

TWO-FOOT FOUR-FOLD
No. 332w.



Arch joint, brass pin holes. Marked 8ths and 16ths, and scales, bevelled edges.
Width, 1 in., 3/-; 1 1/2 in., 4/- each.

FOLDING LATHS
For Builders and Architects. 5 ft. long.

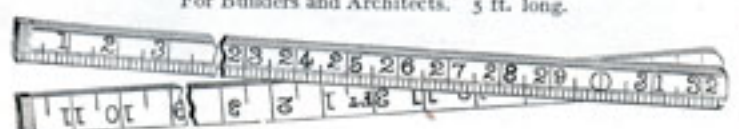

No. 336w. Boxwood, with spring stop joint. Marked feet and inches on one side ... 6/6 each.
No. 337w. Marked as above. In Lancelwood. Black with White figures. Price 7/6 each.

THIN FOLDING RULES
No. 339w.

Marked in English and Metric. Rivet joint.

Length ...	3	4	5	6	ft.
Price ...	1/-	1/4	1/9	2/3	each.

TWO-FOOT FOUR-FOLD
No. 325w.



Arch joint, Brass bound.
Marked 8ths, 10ths, 12ths, and 16ths.
Width, 1 in., 3/-; 1 1/2 in., 3/9 each.

TWO-FOOT FOUR-FOLD ARCHITECTS' RULES

No. 327w. Arch joint, bevelled edges, with various drawing scales in 8ths, 10ths, 12ths, and 16ths.
4 Scales. Width, 1 in., 3/- each.

No. 328w. 8 Scales, and Brass Edge Plates. Width, 1 in., 3/9; 1 1/2 in., 4/6 each.

No. 329w. 16 Scales, German Silver, and Edge Plates. Width, 1 1/2 in. 10/6 each.
No. 330w. 8 Drawing and 4 Chain Scales, 8 Bevels, German Silver. Width, 1 in., 8/6; 1 1/2 in., 10/6 each.

TWO-FOOT FOUR-FOLD
With Brass Slide.

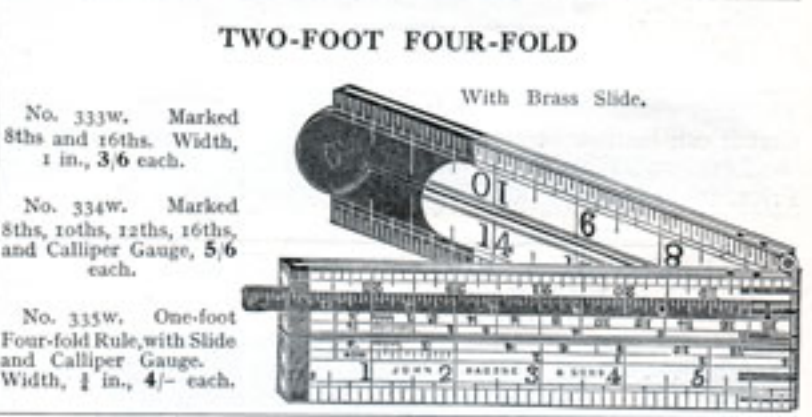

No. 333w. Marked 8ths and 16ths. Width, 1 in., 3/6 each.

No. 334w. Marked 8ths, 10ths, 12ths, 16ths, and Calliper Gauge, 5/6 each.

No. 335w. One-foot Four-fold Rule, with Slide and Calliper Gauge. Width, 1/2 in., 4/- each.

FIVE-FOOT FOLDING SURVEYOR'S RULE
No. 338w.

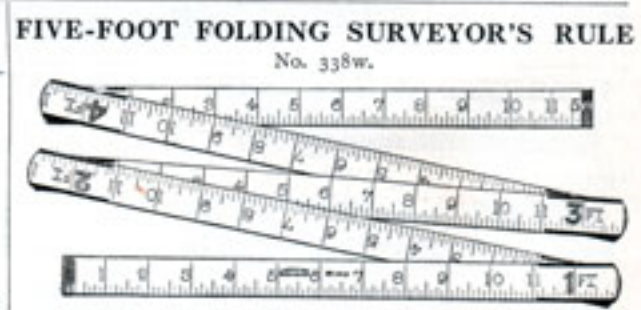

Boxwood, 1/2 x 1/8 in., with spring joints. Marked inches and 8ths. Price ... 7/6 each.



TOOL AND MACHINE MERCHANTS



TWO-FOOT FOLDING RULES

- 1 1/2 in. wide.
- No. 340w. Arch Joint, marked 8ths, 16ths, and Square Line. Price 1/3 each.
- No. 341w. Ditto, 2 Scales, 8 Square Line, Bevelled Edge, marked 8ths and 16ths. Price 1/6 each.
- No. 342w. Ditto, 4 Scales, 8 Square Line, Double Bevelled Edge, marked 8ths and 16ths. Price 2/6 each.

TWO-FOOT FOLDING RULES

With Brass Slide. 1 1/2 in. wide.

- No. 343w. 2 Scales, Bevelled Edge, marked 8ths. Price 2/- each.
- No. 344w. 4 Scales, Bevelled Edge and Angles, marked 8ths. Price 3/- each.
- No. 345w. 2 Scales and 8 Square Line, Bevelled Edge, Slide, marked 8ths and Gunter's Line. Price 3/6 each.
- No. 346w. 6 Scales, 8 Square Line, and Gunter's Line, Bevelled Edge. Price 5/- each.



TWO-FOOT FOUR-FOLD RULES

With very bold markings.

Size of figures, 1/2 in.

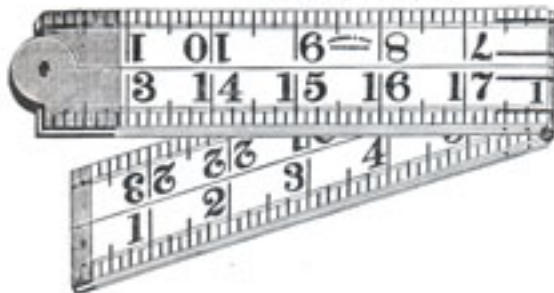

- No. 347w. Width, 1 1/2 in. Marked in 8ths and 16ths. Price 2/6 each.
- No. 348w. 3 ft. Price 3/- each.

TWO-FOOT FOUR-FOLD

With Circle of Degrees and Spirit Level.

No. 349w.

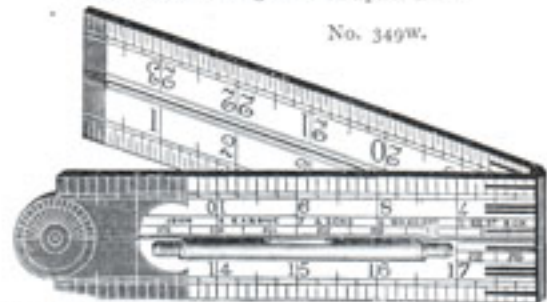

Marked 8ths, 10ths, 12ths, 16ths, and Scales. 1 1/2 in. wide. Price 5/6 each.

TWO-FOOT FOUR-FOLD

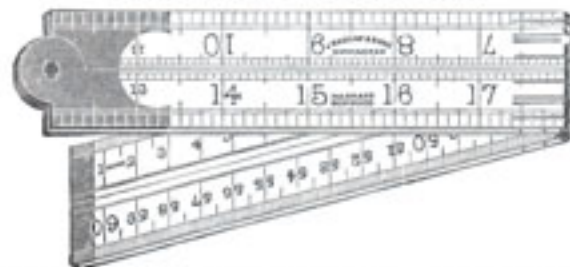

- No. 350w. Marked English and Metric. Price 2/- each.
- No. 351w. As above, 3 ft. Price 2/6 each.
- The above are marked 8ths and mm.

THREE-FOOT FOUR-FOLD

Marked 8ths, 10ths, 12ths, and 16ths.



- | | | | | | | | |
|-----------|-------|-----|-----|-----|-------|-------|-------|
| Width | ... | ... | ... | 1 | 1 1/2 | 1 1/2 | in. |
| No. 352w. | Price | ... | ... | 1/9 | 2/2 | 2/6 | each. |
- No. 353w. Marked 8ths, 10ths, 12ths, and 16ths, with various drawing scales, and inside edges bevelled. Width, 1 1/2 in. With Edge Plates. Price 6/-

BOXWOOD ROPE AND CHAIN GAUGE



- No. 354w.
- 4 in. long 3/9
- 6 " 5/-

BOXWOOD BUTTON GAUGE

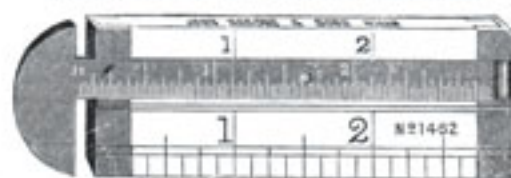

No. 356w. Slide marked in 32nds. Price 2/- each.

PATTERN MAKERS' CONTRACTION RULES

24 in. Boxwood. Marked inches in 16ths with Bevelled Edge.

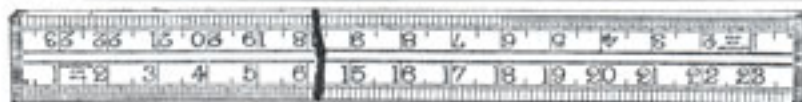

- Prices:
- No. 357w. Standard and Single Contraction for Iron, 5/9 each.
- No. 359w. Ditto, for Iron and Brass, 5/9 each.

Electric and Wireless Engineers

RICHARD MELHUISE LIMITED, LONDON, E.C.

ONE-FOOT FOUR-FOLD, GERMAN SILVER MOUNTS. Ivory

No. 360w. $\frac{1}{2}$ in. wide, Round Joints, Brass Mounts. Price 5/6

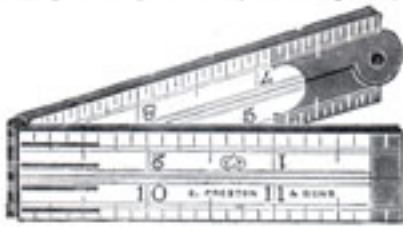

No. 361w.
 $\frac{1}{2}$ in. wide, Arch Joint, marked 8ths, 10ths, 12ths, 16ths, and Scales. Price 13/- each.

No. 362w.
Ditto, with Edge Plates. Price 14/- ea.

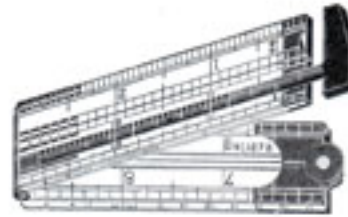

No. 363w.
 $\frac{1}{2}$ in. wide, Arch Joint, marked 8ths, 10ths, 12ths, 16ths, and Scales, with Calliper Gauge, in 16ths and 32nds. Price 22/6 each.

TWO-FOOT FOUR-FOLD (Ivory)

No. 364w. Marked 8ths, 10ths, 12ths, 16ths, German Silver Mounts.

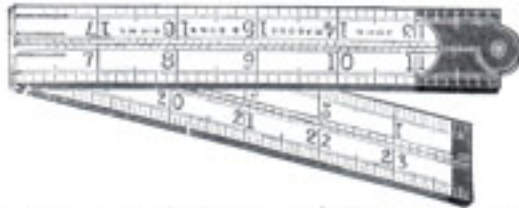

$\frac{1}{2}$ in. wide. Price 27/6 each. $\frac{3}{4}$ in. wide, 35/- each.

TWO-FOOT FOUR-FOLD (Ivory)

No. 365w.

With Bevelled Edge. Marked 8ths and 16ths, with 16 Drawing Scales.

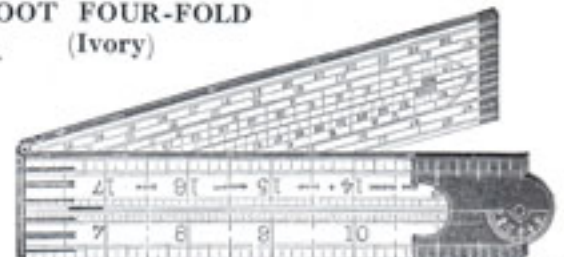

$\frac{1}{2}$ in. wide. Price 36/6 each. $\frac{3}{4}$ in. wide, with degrees, 45/- each.

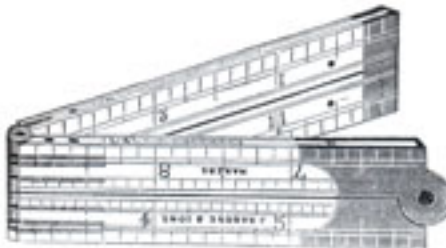

ONE-FOOT FOUR-FOLD (Boxwood)

No. 366w.
Arch Joint (as illustrated).
Width, $\frac{1}{2}$ in., 1/6 ea.
Round Joint.
Width, $\frac{1}{2}$ in., -10 ea.



TWO-FOOT TWO-FOLD BOXWOOD RULE

No. 367w.
Scales and 8 Square Line, degrees on Brass Plate, Brass Tips, and Spirit Level. $\frac{1}{2}$ in. wide. Price 6/- each.

BEST BOXWOOD BENCH RULES (Brass Tipped)

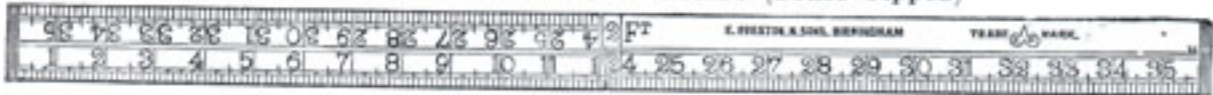

No. 368w. Marked in 8ths. $\frac{1}{2} \times \frac{1}{2}$ in.
Length ... 24 ... 36 ... 48 ... 60 ... 72 in.
Price ... 3/- ... 3/6 ... 5/6 ... 7/- ... 9/6 each.



No. 370w. Marked in 8ths on one edge of each side. $\frac{1}{2}$ in. wide, $\frac{3}{8}$ in. thick, 36 in. long. Price 2/6 each.
No. 371w. Mahogany Straight Edge. 36 in. long. Price 4/6 each. No. 371 $\frac{1}{2}$ w. Deal Straight Edge. 60 in. long. Price 3/6 each.

ROUND YARD MEASURES WITH BRASS FERRULES AT ENDS



No. 372w.
Marked in inches and 8ths.
Price 2/- each.



No. 373w. $\frac{1}{2}$ in. wide. Parts of a yard, price 2/6 each. Marked in 8ths. Price 2/9 each.

BRASS COUNTER MEASURES

BEST BOXWOOD GLAZIER'S SQUARE

Length ... 24 ... 30 ... 36 ... 48 in.
Price ... 4/6 ... 5/3 ... 6/- ... 7/6 each.

No. 374w.



GLAZIER'S LATH. See No. 368w above.



TAILOR'S OR DRESSMAKER'S SQUARE

No. 375w. Polished Boxwood. Marked in 8ths.

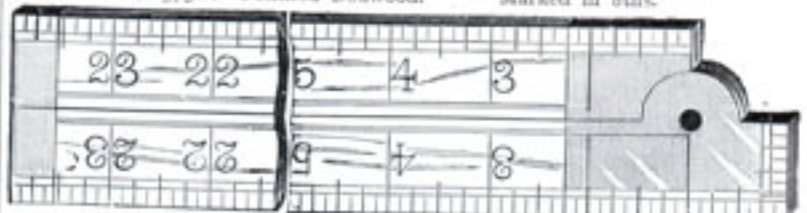

Size 24 x 18 in. Price 5/- each. Size 27 x 18 in. Price 5/6 each.

Bronze Medal 1884—Gold Medal 1890

TOOL AND MACHINE MERCHANTS

LINEN MEASURING TAPES

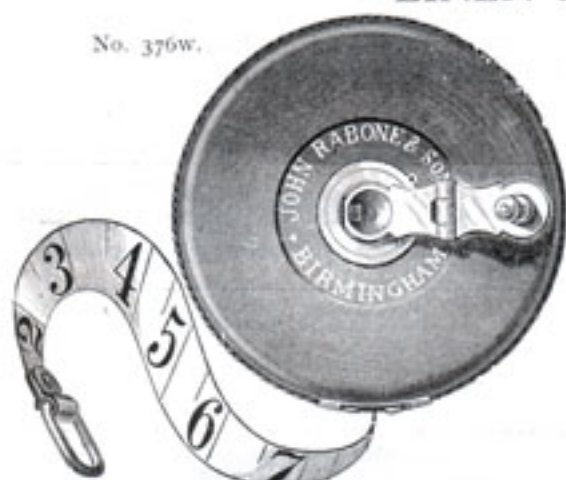

No. 376w.

IN
LEATHER
CASES.

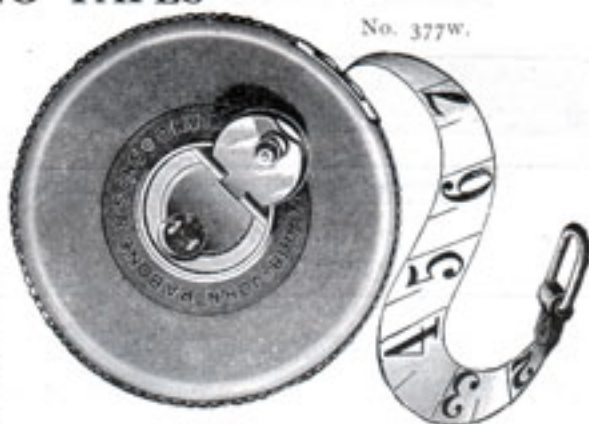

No. 377w.

As used by the various ordnance departments in Great Britain and other countries.

No.	Marked in English and Metric.	Folding handle.	Width, $\frac{1}{2}$ in.	Length ...	33	50	66	100	ft.
No. 376w.	Flush			Price ...	8/-	9/6	10/6	14/6	each.
" 377w.	Flush			" ...	8/9	10/6	11/6	15/6	"
" 378w.	Chaper pattern.	Folding handle.	Width, $\frac{1}{4}$ in.	" ...	6/-	8/-	9/6	12/6	"

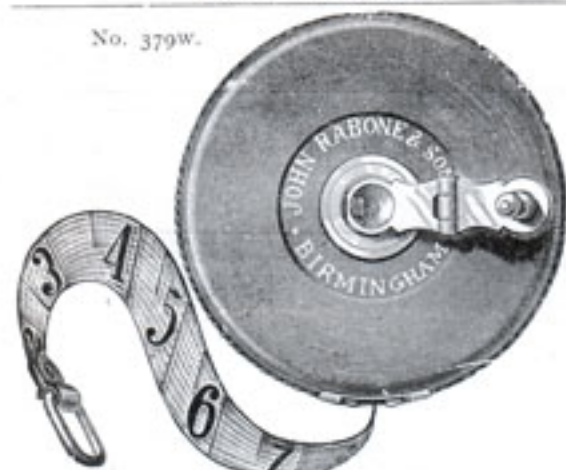

No. 379w.

BEST QUALITY METALLIC TAPES

In Strong
Leather Cases.

Any of the above can be supplied marked in feet and half-inches if preferred.

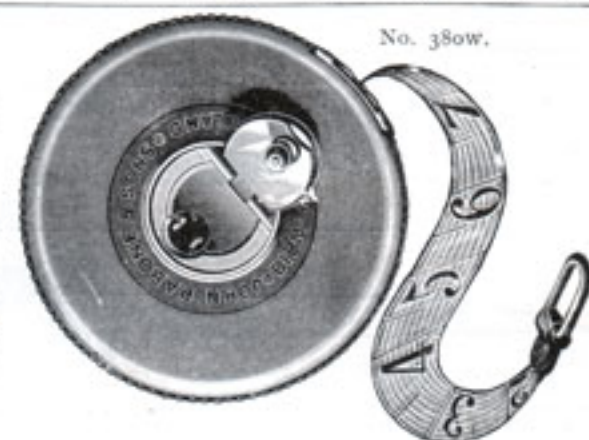

No. 380w.

No.	Marked English and Metric.	Folding handle.	Width, $\frac{1}{2}$ in.	Length of Tape ...	25	33	50	66	75	100	ft.
No. 379w.	Flush			Price ...	8/-	9/-	11/6	13/6	15/-	18/-	each.
" 380w.	Flush			" ...	9/-	10/-	12/6	14/6	16/-	19/-	"

SPRING POCKET MEASURES WITH LINEN TAPES



No. 381w. Marked English and Metric. Brass Case and Spring Stop.

Length ...	3	6	9	ft.
Price ...	3/-	4/-	5/-	each.



No. 382w. Marked inches in 8ths one side, Metric on the other side.

Length ...	3	6	ft.
Price ...	2/-	2/9	each

SPRING POCKET MEASURES WITH STEEL TAPES



No. 383w. Marked inches in 16ths one side, Metric on the other side. Brass Case with Stop.

Length ...	3	6	9	12	ft.
Price ...	4/3	6/6	8/6	9/6	each.



No. 384w. Marked inches in 16ths on one side, Metric on the other side.

Length ...	3	6	ft.
Price ...	3/-	4/9	each.

Engineers' Tools and Machinery

MELHUISH'S CELEBRATED FORGED STEEL CHISELS



FIRMER CHISEL
No. 385w.
With Ash Handles.

FIRMER CHISELS
No. 386w.
With Oval Box Handles.



FIRMER CHISELS
No. 387w.
With Bevelled Edges and Oval Box Handles.

BEVELLED EDGE FIRMER CHISELS No. 388w.
With Octagon Box Handles.



REGISTERED CHISELS
No. 389w.
With Ash Handles and 2 Iron Ferrules.

LONDON PATTERN SASH MORTISE CHISELS

No. 390w.
Solid Bolsters.



BEST JOINERS' MORTISE CHISELS
No. 391w.
Beech Handled.

LONG, THIN PARING CHISELS

No. 392w.
With Bevelled Edges and Octagon Box Handles.



BEST CAST STEEL SOCKET CHISELS
No. 393w.

WARD'S CELEBRATED CHISELS

No. 394w.
With Beech Handles, as shown.



Size
385w.	{With Ash Handles	...	-9	-9	-9	-9	-10	-10	-11	1/-	1/0 1/2	1/2	1/3	1/7	2/-	2/4	2/9 ea.				
	{Unhandled	...	-6	-6	-6	-6 1/2	-6 1/2	-8	-8 1/2	-9	-10 1/2	1/-	1/3	1/6	2/-	2/4					
386w.	{With Oval Box Handles	...	-11 1/2	-11 1/2	-11 1/2	-11 1/2	1/-	1/-	1/1 1/2	1/2	1/2 1/2	1/5	1/6	1/10	2/2	2/6	2/11	..			
	{Ditto, with Bevd. Edges	...	1/5	1/5	1/5	1/5	1/5	1/6	1/7	1/8	1/8	1/10	1/11	2/6	2/10	3/6	4/-	..			
387w.	{Unhandled, B.E.	...	-11 1/2	-11 1/2	-11 1/2	-11 1/2	1/-	1/1	1/2	1/2	1/3	1/4	1/6	2/-	2/3	2/10	3/3	..			
388w.	{With Oct. Box Handles	...	1/7	1/7	1/7	1/7	1/7	1/8	1/8 1/2	1/9	1/10	2/-	2/1	2/8	3/-	3/8	4/3	..			
389w.	{Registered	...	—	—	—	1/5	1/5	1/5	1/5	1/7	1/8	1/9	1/11	2/4	2/10	—	—	..			
390w.	{Sash Mortise	...	—	2/6	2/7	2/7	2/7	2/9	3/2	3/6	—	—	—	—	—	—	—	..			
391w.	{Joiners' Mortise	...	—	2/8	2/9	2/9	2/9	2/10	3/2	3/8	3/9	—	—	—	—	—	—	..			
392w.	{Oct. Box Handle Paring	...	—	—	—	2/2	—	2/3	2/3	2/4	2/6	2/8	2/10	3/8	4/3	5/-	5/9	..			
	{Unhandled Paring	...	—	—	—	1/7	—	1/7	1/8	1/9	1/11	2/-	2/3	3/2	3/8	4/6	5/-	..			
393w.	{Socket Chisel	...	—	—	—	1/6	—	1/6	1/6	1/8	1/9	1/11	2/2	2/6	2/10	—	—	..			
394w.	{Ward's Chisel	...	—	1/-	1/-	1/-	1/1	1/2	1/3	1/3 1/2	1/4	1/6	1/7	1/10	2/3	—	—	..			

Builders' and Furnishing Ironmongery

TOOL AND MACHINE MERCHANTS

MORTISE MACHINE CHISEL



No. 395w. Plain—

$\frac{1}{2}$ in.	$\frac{3}{4}$ in.	1 in.	$1\frac{1}{4}$ in.	$1\frac{1}{2}$ in.	$1\frac{3}{4}$ in.	2 in.	$2\frac{1}{4}$ in.	$2\frac{1}{2}$ in.	$2\frac{3}{4}$ in.	3 in.
5/-	5/-	5/6	5/6	5/9	5/9	6/-	6/-	6/6	7/6	8/-
No. 396w. Self-coring Pattern.										
11/-	11/-	11/-	11/-	11/6	11/6	12/-	12/-	12/6	13/6	15/-

DRAW BORE PINS No. 397w.

With Box Handle.

Size	... $8 \times \frac{1}{2}$	$10 \times \frac{1}{2}$ in.
Price	... $2/9$	$3/3$ each.



EYED DRAW BORER No. 398w. Size $9 \times \frac{1}{2}$ in. Price 2/- each.

SETS OF FIRMER CHISELS

No. 399w. See page 32.

Set of 12.	$\frac{1}{2}$ to 1 in.	With Ash Handles	Bevelled Edge ...	16/6 per set.
" 12.	$\frac{1}{2}$ " 1 " "	"	"	"	"	"	"	"	19/-
" 12.	$\frac{1}{2}$ " 1 " "	Octagon Boxwood Handles	"	23/-
" 12.	$\frac{1}{2}$ " 1 " "	Carver's Oval Boxwood Handles	"	21/-

AMERICAN SOCKET FIRMER CHISELS

No. 400w.



These Tools are tempered by an improved process, ensuring a perfect cutting edge, the blade and socket of the Chisel being highly polished, and socket fitted with Hardwood handle.

Size	$\frac{1}{2}$	$\frac{3}{4}$	1	$1\frac{1}{4}$	$1\frac{1}{2}$	$1\frac{3}{4}$	2 in.
Price	$3/-$	$3/-$	$3/1$	$3/2$	$3/6$	$3/9$	$4/-$ $4/6$ $4/9$ $5/6$ $5/9$ ea.

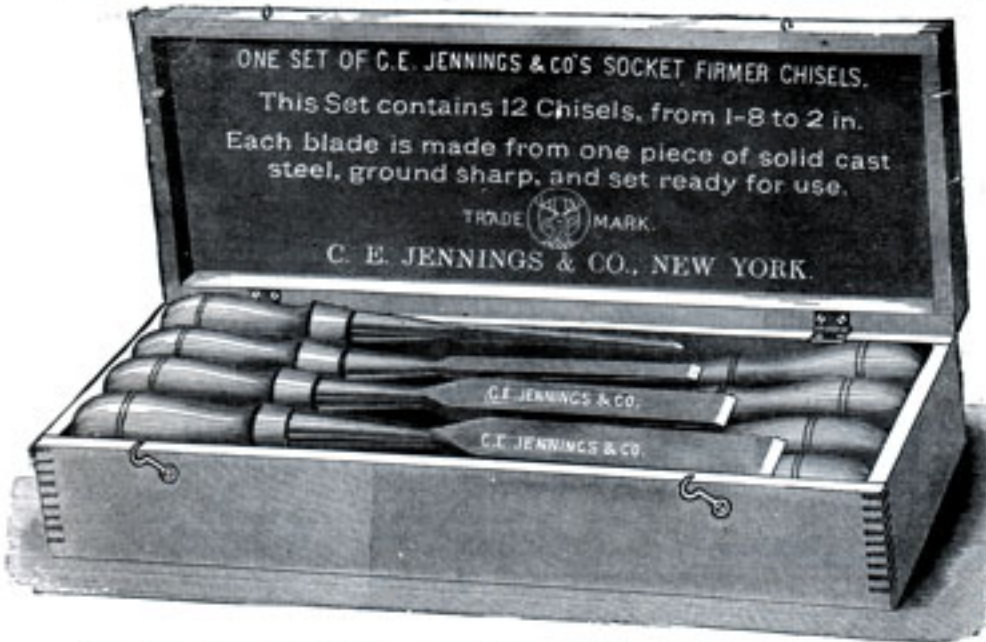

SASH POCKET CHISEL

No. 401w. Handled.



Size	...	$1\frac{1}{2}$	$1\frac{1}{2}$	2	$2\frac{1}{4}$	$2\frac{1}{2}$ in.
Price	...	$1/6$	$1/9$	$2/-$	$2/4$	$3/-$ ea.

BUTTON-HOLE CHISEL

No. 402w.



Size	...	$\frac{1}{2}$	$\frac{1}{2}$	$\frac{1}{2}$ in.
Price	...	$-/9$	$-/10$	$-/11$ each.

SET OF TWELVE ASSORTED

No. 403w.

Sizes from $\frac{1}{2}$ to 2 in.
Polished Wood Box.
Price 52/6 complete.

TURNING TOOLS

No. 404w.

For Hardwood, Ivory, and Metals.

Price 1/- each.

Boxwood Handles, -/6 each.

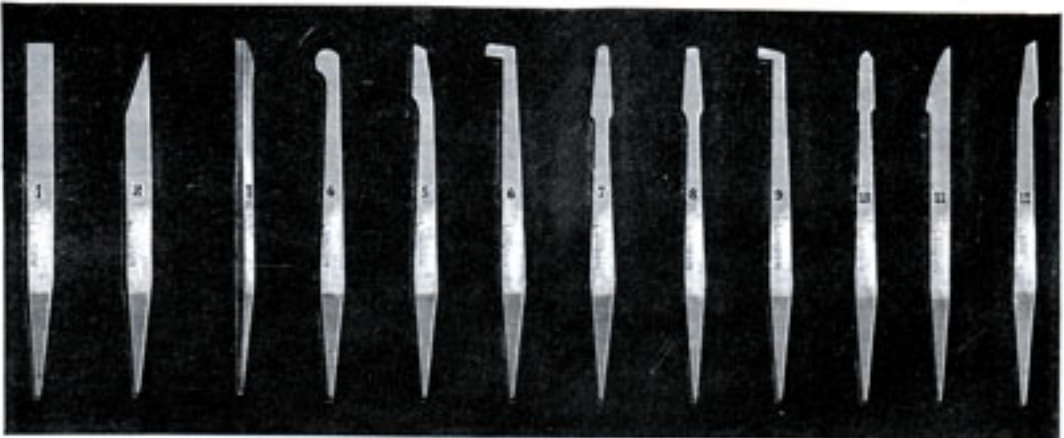

Horticultural and Estate Appliances

RICHARD MELHUIH LIMITED, LONDON, E.C.

MELHUIH'S CELEBRATED EDGE TOOLS

CAST STEEL FIRMER GOUGES
No. 405w.
With Round Ash Handles.



C.S. SCRIBING GOUGES
No. 406w.
Handled in Ash. Inside Cannelled.

BEST QUALITY CAST STEEL SOCKET GOUGE
No. 407w.



WARD'S FIRMER GOUGES
No. 408w.
With Beech Handles.

LONG THIN PARING GOUGES

Handles in Ash, -/3;
in Box, -/6 extra.



No.	Size	1/8	3/8	1/2	5/8	3/4	7/8	1	1 1/8	1 1/4	1 1/2	1 3/4	2 in.	
405w.	Firmer Gouge	-/11	-/11	-/11	-/11 1/2	-/11 1/2	1/-	1/-	1/1	1/2	1/3	1/5	1/10	2/2 ea.
406w.	Scribing	1/1	1/1	1/1	1/2	1/2	1/2 1/2	1/3	1/4	1/5	1/6	1/7	—	—
407w.	Socket	—	—	1/10	1/10	1/10	1/10	1/10	2/-	2/-	2/2	2/4	2/10	3/3 ..
408w.	Ward's	1/2	1/2	1/2	1/2 1/2	1/2 1/2	1/3	1/3	1/4	1/5	1/6	1/8	2/1	2/5 ..
409w.	Paring Gouge blades,				—	—	1/5	—	1/6	—	1/7	1/8	1/10	1/11	2/3	2/9	3/4 ..
	sweeps A, B, C, D, and E				—	—	1/6	—	1/7	—	1/9	1/10	2/-	2/1	2/5	2/11	3/6 ..
	Ditto, sweep F				—	—	1/6	—	1/7	—	1/9	1/10	2/-	2/1	2/5	2/11	3/6 ..

For sweeps see page 159.

TURNING CHISELS
No. 410w.

Handled in Polished Beechwood.



TURNING GOUGES
No. 411w.

Handled in Polished Beechwood.

Size	1/8	3/8	1/2	5/8	3/4	7/8	1	1 1/8	1 1/4	1 1/2	1 3/4	2 in.	
No. 410w	1/3	1/3	1/3	1/4	1/4	1/6	1/7	1/9	1/10	2/3	2/9	3/3	3/10 each
.. 411w	Blade only	-/9	-/9	-/9	-/9 1/2	-/10	1/1	1/1	1/2	1/3	1/9	2/2	2/9	3/3 ..
.. 411w	Blade only	1/5	1/5	1/5	1/6	1/8	1/9	2/-	2/2	2/4	3/2	3/10	4/6	— ..
.. 411w	Blade only	-/11	-/11	-/11	1/-	1/1	1/3	1/5	1/7	1/10	2/4	3/3	3/9	— ..

No. 412w. Set of 6 assorted Chisels, to 1 in., 12/6 per set.
No. 414w. Set of 8 assorted Gouges, to 1 in., 15/- per set.
.. 413w. Set of 6 Light Turning Tools for Wood, 8/- per set.
.. 415w. Set of 6 ditto for Wood and Metal, 10/6 ..

"V" TURNING TOOL

Fitted with Beechwood Handle.

Size, 1/4, 3/8, and 1/2 in. Price 2/6 each.



WHEELER'S BRUZZ No. 417w.



Length, 14 in.
Size 1/4 3/8 1/2 in.
Price... .. 5/- 5/3 5/6 each.
Handles, -/9 each extra.

IMPROVED PATTERN LOCK MORTISE CHISEL

Size 1/2 3/4 1 in.
Price 5/3 5/6 5/8 each.
Beech Handle, -/6 each extra.



Electric and Wireless Engineers

TOOL AND MACHINE MERCHANTS

SCREWDRIVERS

LONDON PATTERN No. 419w.

Cast Steel Blades, spring temper, cut into Strong Brass Ferrules.

Blade ...	3	4	5	6	7	in.
Price ...	-/8	-/10	1/-	1/1	1/4	each.
Blade ...	8	9	10	12		in.
Price ...	1/8	1/10	2/3	3/-		each.



Prices of Second Quality on application.



CABINET PATTERN

Highest quality worked Oval Handles. In Selected Beech and Box.

Blade	3	4	5	6	7	8	9	10	12	in.
No. 420w. Oval Beech Handles ...					1/-	1/1	1/3	1/6	1/9	2/-	2/6	2/9	3/6	each.
.. 421w. .. Boxwood Handles					1/4	1/6	1/9	2/-	2/6	2/8	3/-	3/6	4/6	..

REGISTERED PATTERN No. 422w.

With Oval Boxwood Handle.

Blade	3	4	5	6	7	8	9	10	in.
Price	-/10	1/-	1/3	1/6	1/9	1/10	2/-	2/3	each.



THE ELECTRICIAN'S PATTERN

No. 423w.

Registered Pattern as above, with Box Handles.
Size ... $6 \times \frac{1}{2}$ $8 \times \frac{3}{8}$ $10 \times \frac{1}{2}$ in.
Price ... $\frac{1}{3}$ $\frac{1}{9}$ $\frac{2}{-}$ each.



ELECTRICIAN'S No. 424w.

Round Beech Handle.

Blade ...	$4 \times \frac{1}{2}$	$6 \times \frac{1}{2}$	$8 \times \frac{3}{8}$	$10 \times \frac{1}{2}$	in.
Price ...	-/5	-/6	-/9	1/1	each.



POCKET SCREWDRIVER

No. 425w. With $1\frac{1}{2}$ in. Blade.



Handled in Beech ...	1/3	each.
.. Box ...	1/6	..

KNURLED BLADE

No. 426w.

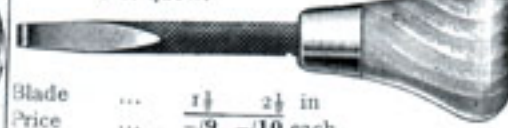

Blade ...	$1\frac{1}{2}$	$2\frac{1}{2}$	in.
Price ...	-/9	-/10	each.

MIDGET PATTERN

No. 427w.

Beech Handle and Brass Ferrule. Length of Blade, $1\frac{1}{2}$ in.
Price -/6 each.

POCKET SCREWDRIVER SET No. 428w.

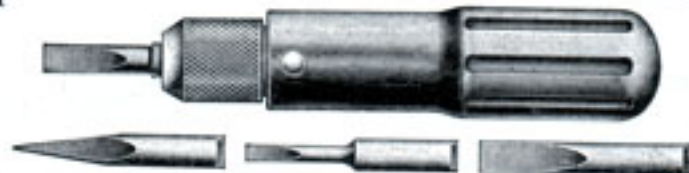

This little Pocket Screwdriver Set, with three blades of assorted sizes, and one reamer for making or enlarging holes, will be found most convenient and attractive. In the explanatory cut the tool is shown in its closed form, with a side cut away to show the location of the different blades in the handle. The tool is fully polished, nickel-plated, and buffed. It is $3\frac{1}{2}$ in. long closed, and weighs 4 oz. Price 4/6 each.



PERFECT PATTERN SCREWDRIVER

No. 429w.

Made from High-grade Sheffield Steel.

Length overall...	4 $\frac{1}{2}$	6	8	10	12	14	16	in.
Price ...	-/10	1/-	1/4	1/10	2/6	3/3	3/9	ea.



PISTOL GRIP RATCHET SCREWDRIVER

No. 430w.

This improved Screwdriver gives a firm grip to turn the most stubborn screw. It is a natural grip and will not tire the hand. Easy running screws may be quickly turned without taking the hand from the handles with the knurled ferrule.

Two widths of blades are furnished to fit common size screws. The reamer is handy in starting screws and similar work. The blades are changed without adjustments.

Set consists of handle, two blades, and reamer.

Length of Blade	6	8	in.
With two Blades and Reamer, price	9/6	10/-	each.

Bronze Medal 1884—Gold Medal 1890

RATCHET SCREWDRIVERS

RIGHT AND LEFT HAND, AND RIGID

The friction in ratchet mechanism is so slight as to be hardly felt, the backward movement is as easy as in a good "stem-winder," and just as noiseless. The construction of ratchet and pawls is such that neither can bend, break, wear, nor get out of order.

The bits are forged from best cast steel, properly tempered, ground, and polished, and every bit is thoroughly tested before leaving factory. Other metal parts are nickel-plated and buffed. The handles are made of hard wood, smoothly and handsomely polished.



No. 431W/10.



No. 432W/15.

Length of blade	2	3	4	5	6	in.
No. 431W/10. Price	2/6	3/3	3/6	3/9	4/3	each.
" 432W/15. "	2/9	3/-	3/2	3/4	—	"

Similar to above, but all sizes have $\frac{1}{8}$ in. diameter blade, and differ only in length. On the blade is a knurled washer, so blade can be turned with finger and thumb while it presses on handle to hold screw in place. Largely used by electrical workers.

G.P. PATTERN. Right or Left.

Changed from right to left by turning the knurled ferrule to the right or left.

Length of blade	1 1/2	2	3	4	6	8	10	in.	
Price	...	3/-	3/3	3/9	4/-	5/-	5/3	6/-	each.



No. 433W.

It drives or draws screws by pushing on handle, or by ratchet movement, and can be made rigid as an ordinary screwdriver by a lock when closed. Its advantages over all similar tools are its greater simplicity, compactness, strength, durability, and easy operation.

Three bits of different widths are included with each tool.



No. 434W/30a.

REGULAR OR STANDARD SIZE

Extreme length with bit in chuck is 13 1/2 in. when closed, and 19 1/2 in. when extended.

Price	12/-
-------	-----	-----	-----	-----	-----	-----	-----	-----	------

No. 435W/31a.

HEAVY PATTERN

Extreme length with bit in chuck is 17 1/2 in. when closed, and 26 1/2 in. when extended.

Price	16/-
-------	-----	-----	-----	-----	-----	-----	-----	-----	------

LIGHT PATTERN

Small enough to be carried in pocket, weighs 7 oz., and only 7 in. long without bit. Length with bit in chuck 9 1/2 in. when closed, and 12 1/2 in. when extended.

Price	9/-
-------	-----	-----	-----	-----	-----	-----	-----	-----	-----



No. 436W/35.



No. 437W/20.

For screwing in only. Not reversible.

No.	1	2	3	in. extended.
Length	...	14	17	19	in. extended.
Price	...	7/6	9/-	10/-	each.

QUICK RETURN PATTERN



These are the regular patterns Nos. 30, 31, and 35, with a spring added in the handle, as shown in cut, which causes the handle to come back for the next push, in driving screws in or out.

They are "quick return," and more rapid and convenient in practical use than pulling the handle back.

They are especially appreciated by workmen who are driving screws continually in narrow, deep places where the left hand cannot be used to hold the chuck end of the driver. It can be successfully used with one hand driving the tool, as the spring keeps bit in position as it forces the handle back for the next stroke.

This is the same size as 434W/30a, except that it has a spring in the middle, causing quick return of the handle.

No. 438W/130a. Price	13/6	No. 439W/131a. Same size as No. 435W/31a. Price	18/-
----------------------	------	---	------



CHUCK AND EIGHT DRILLS

No. 441W.

For Screwdrivers Nos. 20, 30, 31, 35, 130, and 131.

Price complete	...	3/9
----------------	-----	-----



No. 442W.

COUNTERSINK

For Nos. 30 and 130.

" 31 " 131.

" 35 " 135.

Price	...	1/-
-------	-----	-----

POCKET SCREW-DRIVER SET



This has four interchangeable blades. It is steel, nickel-plated and polished. Length, 3 in.

Price	...	4/-
-------	-----	-----

TOOL AND MACHINE MERCHANTS

ARCHIMEDIAN DRILL

No. 444w.
With Universal Head and 6 Bits.
6 8 10 12 in.

Price... 2/- 2/3 2/6 3/6 each.



RECIPROCATING DRILLS FOR STEEL, BRASS, WOOD, Etc.

No. 445w.



These Drills are capable of drilling with comparative ease $\frac{1}{4}$ in. Twist Drills in iron will be found very useful for drilling holes where braces, breast drills, or hand drills cannot conveniently be brought into play.

They are so constructed that the Drill runs continuously to the right during both the forward and backward movement, and hence drills continuously. The pressure against the head to feed the Drill is met by a ball bearing to reduce the friction. Price 10/6.

YANKEE DRILL

No. 446w.

With special three-jawed chuck to hold any drill with straight shank $\frac{3}{8}$ in. diameter or less. To open or close chuck, move driver up to chuck and push down catch in lower end of driver, which holds fast driver on spindle. After Drill is put in chuck and tightened, push up catch, releasing driver from spindle so that it can be moved back and forward to operate Drill. Movement of driver is $8\frac{1}{2}$ in. Tool is 16 in. long over all, without Drill. Price, without Drills, 16/- each. Set of 6 short Twist Drills, $\frac{1}{8}$ - $\frac{3}{8}$ in., 2/- extra.



No. 447w.

YANKEE PUSH BRACE



This tool is so named because it will hold all the small tools used in a bit brace, but is operated by pushing the handle to revolve the tools, in the same manner as in the "Yankee" Spiral Ratchet Screwdriver.

It will, with little effort, bore $\frac{3}{8}$ in. holes in metal, drive $\frac{1}{2}$ in. auger bit in hard wood, and $\frac{1}{4}$ or $\frac{3}{8}$ in. bits in white pine. It can be used for drilling, tapping, and as a screwdriver.

Extreme length, without bit, extended, 23 $\frac{1}{2}$ in.; closed, 16 $\frac{1}{2}$ in.

Price 22/6

AUTOMATIC BORING TOOL

No. 448w.

This has eight drill points all stored in separate compartments in the handle, the numbers on the outside designating the location of each size. By pressing slightly upon a pin, the cap can be turned to either right or left, until the hole is opposite the desired number, when the drill can be readily removed. Price 8/6



Length over all, 11 in. Price 5/-

YANKEE AUTOMATIC DRILL

No. 449w.

This is for light work only, and is furnished with three drill points, $\frac{1}{8}$, $\frac{3}{16}$, $\frac{1}{4}$ in. In wood box.

YANKEE DRILL No. 450w.

This is heavier than No. 449w, and has a set of eight drill points, $\frac{1}{8}$ - $\frac{1}{4}$ in. In wood box. Nickel-plated, with wood handle. Price 8/6



NEW AUTOMATIC DRILL, "MR. PUNCH"

No. 451w.

This is beautifully made and nickel-plated. It has eight fluted drills, sizes $\frac{1}{8}$ - $\frac{1}{4}$ in. Price 9/-

Builders' and Furnishing Ironmongery

RICHARD MELHUISE LIMITED, LONDON, E.C.

HANDLED BRADAWLS



No. 452w.

Round Beech or Ash... .. -/3½ each; 3/3 per doz.
 No. 453w. Ditto, pinned through -/5 .. 4/6 ..



No. 454w.

BEST FORGED STEEL AWL BLADES

Length...	1	1½	1¾	2	2 in.	
Price ...	-/1½	-/2	-/2	-/2	-/2½	each.
..	1/4	1/6	1/9	1/11	2/-	per doz.

SQUARE BLADES

No. 455w.
 Price -/2½ each; 2/- per doz.

HANDLED MARKING AWLS



No. 456w.

Shouldered price -/8 each.

UNHANDLED MARKING AWLS



No. 457w.

Price -/7 each.
 No. 458w. Handled, ditto ... 1/3 ..

LONG PATTERN MAKERS' AWLS

No. 459w.

Price -/3½ each;
 3/3 per doz.

NEW PATTERN MARKING AWL



No. 460w.

Length, 6½ in. Price -/7 each.

PATENT BRASS CAPPED AWLS

No. 461w.



Price -/5 each; 4/9 per doz.

IMPROVED SET OF SIX BRADAWLS

The engraving shows a Combination Bradawl, containing 6 different sizes of Awls. Each Bradawl has a solid iron shank which fits into the iron heading, the end of the shank appearing through the hole, as shown.



No. 462w.

Price 3/3 each.

TOOL SETS OR PADS, Stanley Co.'s Manufacture

No. 463w.



With Twelve Tools

The extra tools are conveniently placed in the ferrule around the socket, where they are in plain view for selection. Price, complete in cocobolo handle, 5/10 each.

The jaws are of malleable iron and permanently secured in the chuck body. The wing nut, jaws, and ferrule are nickel-plated.

With each handle, 10 tools are furnished as follows: 1 each, Gimlet, Chisel, Reamer, Scratch Awl; 2 Screwdrivers, Tack Puller, and 3 assorted Bradawls, hardened, tempered, and with polished tips. They are approximately 2½ in. long.



No. 464w.

Cocobolo handle, 5½ in. long, 10 tools.
 Price 7/9 each.

MILLER'S FALLS TOOL HOLDERS

These are beautifully made. The handles are of cocobolo, chucks and jaws nickel-plated.

No. 465w.

Containing 10 tools. 2½ in. long. Length of handle, 6½ in.
 Price 8/- each.

No. 466w.

The same pattern as above, with the same quantity of tools, but 4 in. long. Length of handle, 7½ in. All fully warranted.

Price... .. 11/6 each.



Horticultural and Estate Appliances

TOOL AND MACHINE MERCHANTS

MILLER'S FALLS TOOL PAD
No. 467w.
Handle of cocobolo, highly polished, chuck and jaws nickel-plated. Length, 6 in. 20 tools, all 1 1/4 in. long.



Price complete 6/6

HANDY SET
No. 468w.
Two Screwdrivers and one Reamer.

Price complete 3/9



HOME COMPANION TOOL SET
No. 469w.

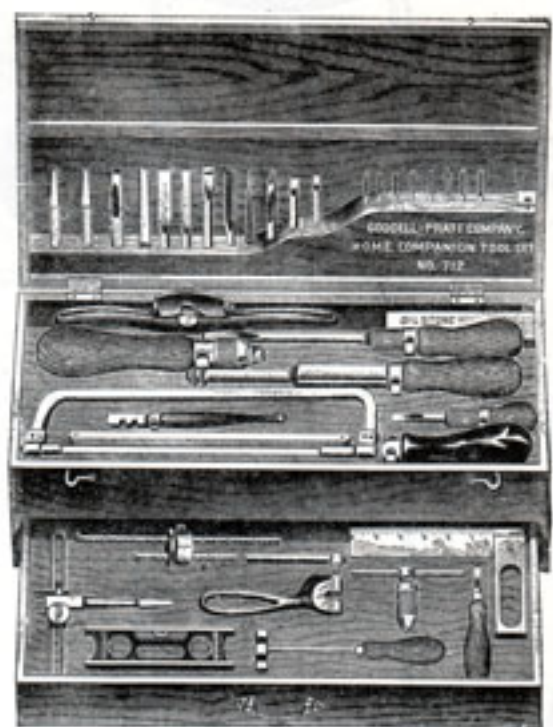

- One 6 in. Graduated Try Square.
- One 6 in. Iron Level with plumb.
- One Washer Cutter.
- One Tool or Tap Holder.
- One Double Beam Combination Roller Gauge.

This set contains the following high-class tools and will be of invaluable service in the home :

- One 6 in. Ratchet Screwdriver.
- One 1 1/2 in. Ratchet Screwdriver.
- One Automatic Drill, with cocobolo handle.
- Eight Drill Points for same, 1/8 to 1/2 in.
- One Universal Tool Handle, with eight blades.
- One Nail Set.
- One Prick Punch.
- One Drive Punch.
- One Hand Shave.
- One Hacksaw Frame.
- Six Hacksaw Blades, coarse.
- Three " " fine.
- Two " " extra fine.
- One Polished Bone Saw for same.
- One Glass Cutter.
- One Solid Punch.
- One Oilstone.
- One 4-in. Iron Level.
- One Brass Hammer.
- One Gunsmith Screwdriver.

Size of Box, 16 x 8 1/2 x 5 1/2 in. Price complete 90/-

REVERSIBLE SCREWDRIVER No. 470w.



The simplest, most compact, strongest, and in every way most practical tool for both driving and drawing screws automatically, and is capable of driving good-size screws or withdrawing those that are tightly fixed. It has a separate spiral for each right- and left-hand twist, which prevents possibility of wear, and the adjustment is neat and instantaneous. The Chuck and eight Drills illustrated will be found a very useful addition to the above Screwdriver. Length, 16 1/2 in. Price 8/6. Chuck and drills, 3/- extra.

SPIRAL RATCHET SCREWDRIVER No. 471w.
AN ENTIRELY NEW AND GOOD TOOL.



An improved Spiral Ratchet Screwdriver, having spiral action for driving or withdrawing screws, right- and left-hand ratchet movements, and a device for making it a rigid screwdriver.

These several actions are plainly marked on the shifter sleeve, which is quickly and easily operated. The spiral locking device is of new design, positive in action, and especially rigid. Clean cut knurling affords an easy grip when operating shifter sleeve and locking collar. Three screwdriver blades of different sizes are furnished with each tool.

	No.	A.	B.	C.
Length, extended, with Bit inserted	...	12	20	26 in.
" closed	...	9	14	17 "
Price	...	8/3	11/3	15/- each.

Electric and Wireless Engineers

BEST QUALITY ENGLISH BRACES



Please refer to our illustrated Metal Workers' List for Engineers' Braces.



PLAIN BRACE No. 472w.

Hardwood head and handle, Steel crank, and hexagon head.

Size ...	5	8	10 in. sweep.
Price ...	3/6	3/7	3/8 each.
No. 473w.	Nickel-plated and Ball Bearing.		
Size ...	5	8	10 in. sweep.
Price ...	4/9	5/3	6/- each.



BALL-BEARING HEAD RATCHET

No. 474w.

Hardwood head and handle, Steel crank, and hexagon head.

Size ...	8	10 in. sweep.
Price ...	8/6	9/6 each.

No. 475w.

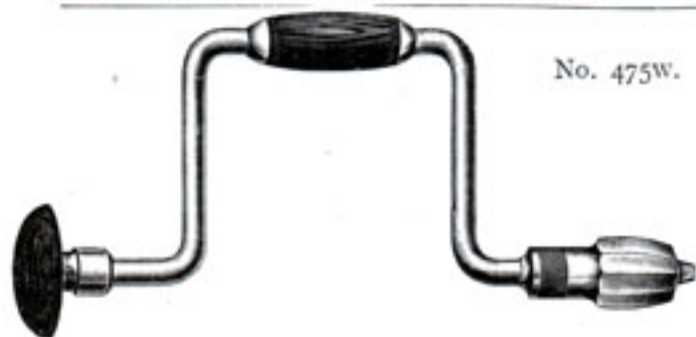

Best quality, with Lignum Vitæ head and Rosewood handle, Steel sweep and jaws, ball-bearing head, and registered chuck.

Size ...	8	10 in. sweep.
Price ...	6/3	7/3 each.

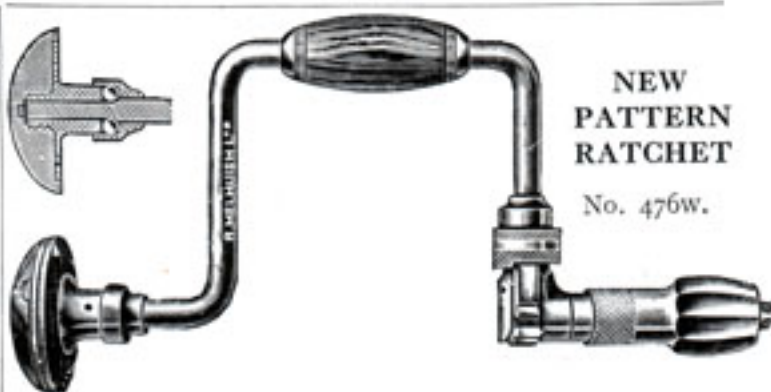

NEW PATTERN RATCHET

No. 476w.

Nickel-plated, with quick-action chuck, ball-bearing Lignum Vitæ head, adjustable Hardwood handle, Steel sweep, and alligator jaws.

Size ...	8	10 in. sweep.
Price ...	13/-	14/- each.

BRACE

No. 477w.

For taking off nuts of motor cars, wheels, etc.



5/8-1/2 in. Whitworth, all bright finish ... 3/6 each.

RATCHET MOVEMENT

No. 478w.

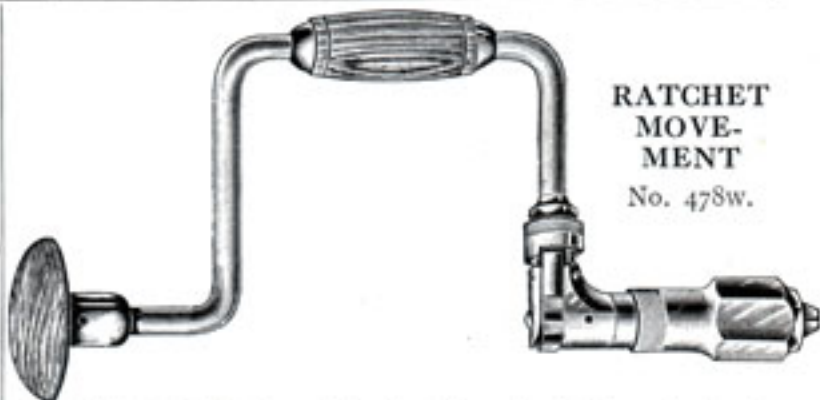

Nickel-plated Teakwood head and handle, ball-bearing head, Steel sweep, and crocodile jaws. Sweep, 10 in. ... 11/6 each.

BEST QUALITY RATCHET BRACE]

No. 479w.



With Lignum Vitæ head and Rosewood handle, Steel sweep and jaws, and registered chuck.

This pattern has, in addition to a ball-bearing head, a ball-bearing handle, viz. each end is fitted with a steel ball race adjusted by steel cones. There is also a ball race between ratchet head and the spindle which carries the jaws.

Size ...	8	10 in. sweep.
Price ...	17/6	19/- each.

Bronze Medal 1884—Gold Medal 1890

TOOL AND MACHINE MERCHANTS

BRACES OF BEST AMERICAN MANUFACTURE

No. 480w.

Stained Hardwood head and handle, exposed parts polished, friction washer fitted to head.

Sweep, 8 in., 7/- each; 10 in., 7/6 each.



THE "HOLDALL" BRACE

No. 481w.

This will hold, accurately and firmly, all varieties of bits, twist drills, etc., with parallel, square, or round shanks, from 1/4 to 1/2 in. in diameter, and No. 1 Morse Taper.

The *unbreakable* socket is made from solid bar steel.

The jaws have parallel milled grooves which grip along their entire length. The head is of cocobolo, also the handle. All exposed parts are nickel-plated. Anti-friction rings are fitted to handle and steel balls to the head.

Sweep, 10 in., 17/9 each; 12 in., 18/6 each.



DRILL BRACE

No. 482w.

This tool is, as the name implies, a combination bit brace and breast drill. It takes but a moment to convert the brace into a drill for the greater power necessary to drill metal, cement, or any hard material. This tool is invaluable to anyone whose work is not confined to one kind of drilling. General construction and capacity as No. 481w. Brace above.

Sweep, 10 in. 28/6 each

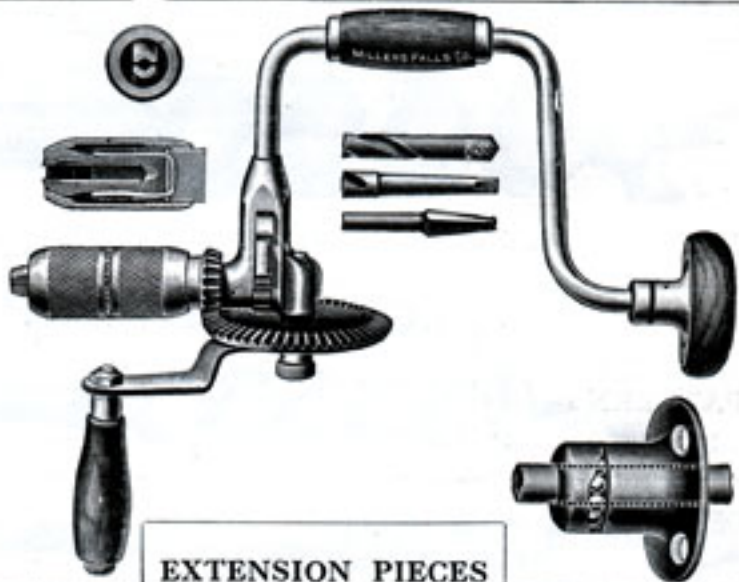

EXTENSION PIECES

No. 483w.

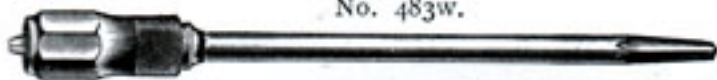

Length, 12 in. ... 3/- | 18 in. ... 3/10 | 24 in. ... 4/6

EXTENSION PIECES

No. 484w.

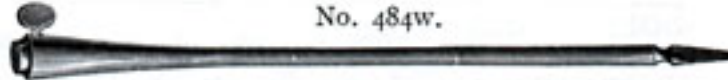

Length, 12 in. ... 2/6 | 18 in. ... 3/3 | 24 in. ... 4/-

HAND RATCHET BRACE

No. 485w.

10 in. long, bright ... 8/9 ea.
10 " Nickel-plated 10/- ..

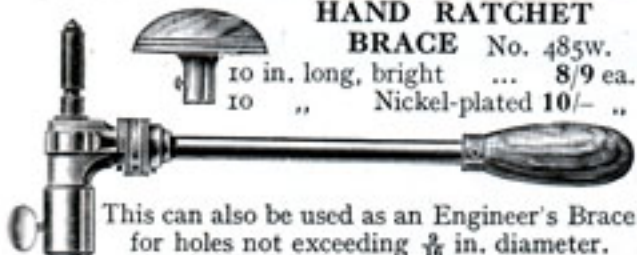

This can also be used as an Engineer's Brace for holes not exceeding 3/8 in. diameter.

LATHE CHUCK

No. 486w.



1/2 or 3/4 in. Shank.
To take ordinary
Brace Bits.

Price ... 3/6 each.

STEEL SPRING JAWS



No. 487w.

Alligator, 1/- each.



No. 488w.

Plain, -/9 each.

RICHARD MELHUISE LIMITED, LONDON, E.C.

AUGER BITS OF HIGHEST CLASS MANUFACTURE



Size	1/4	5/16	3/8	7/16	1/2	5/8	3/4	7/8	1	1 1/4	1 1/2	1 3/4	1 7/8	1 3/4	in.
No. 489w.	Price	1/9	1/9	1/9	1/10	1/10	1/11	2/1	2/4	2/4	2/6	2/9	3/3	3/6	4/6	4/9 each.
" 490w.	"	1/9	1/9	1/9	1/10	1/10	1/11	2/1	2/4	2/4	2/6	2/9	3/3	3/6	4/6	4/9 ..
" 491w.	"	1/10	1/10	1/10	1/11	1/11	2/-	2/2	2/5	2/5	2/7	2/10	3/4	3/7	4/8	5/- ..
" 492w.	"	---	---	3/-	3/3	3/3	3/9	3/10	4/-	4/2	4/8	5/3	---	---	---	---
" 493w.	"	1/9	1/9	1/9	1/10	1/10	1/11	2/2	---	---	---	---	---	---	---	---
" 494w.	"	1/9	1/9	1/9	1/10	1/10	1/11	2/2	---	---	---	---	---	---	---	---

RUSSELL JENNINGS' MAKE



No. 495w.	Size	1/4	5/16	3/8	7/16	1/2	5/8	3/4	7/8	1	1 1/4	1 1/2	1 3/4	1 7/8	1 3/4	in.	
Price	...	2/5	2/3	2/3	2/3	2/4	2/9	2/9	3/2	3/3	3/9	3/9	4/3	5/6	6/6	7/6	8/6 each.

AUGERS OF ENGLISH MANUFACTURE



Size	1/4	5/16	3/8	7/16	1/2	5/8	3/4	7/8	1	1 1/4	1 1/2	1 3/4	1 7/8	1 3/4	2 in.
No. 496w.	Gedge's Eyed, Polished	2/3	2/3	2/3	2/4	2/4	2/9	3/-	3/6	3/8	4/6	4/9	5/3	5/9	6/3	7/6 ca.			
" 497w.	Scotch Pattern, Bright	2/3	2/3	2/3	2/4	2/4	2/9	3/-	3/6	3/8	4/6	4/9	5/3	5/9	6/3	7/6 ..			
" 498w.	Unbreakable Pattern	2/3	2/3	2/3	2/4	2/4	2/9	3/-	3/6	3/8	4/6	4/9	5/3	5/9	6/3	7/6 ..			
" 499w.	Tanged, Gedge's	1/9	1/9	1/9	2/-	2/-	2/3	2/6	2/10	3/3	3/8	4/-	4/6	4/9	5/3	6/3 ..			

Builders' and Furnishing Ironmongery

TOOL AND MACHINE MERCHANTS

EXPANSIVE BITS

Clark's Pattern



No. 530w.

	A.	B.	C.	D.
With two cutters...	$\frac{1}{2}$ -1	$\frac{1}{2}$ -3	$\frac{1}{2}$ -4	$\frac{1}{2}$ -5 in.
Price ...	5/6	8/6	10/6	15/-
Spare cutters	$\frac{1}{2}$ -1	$\frac{1}{2}$ -1	$\frac{1}{2}$ -1	$\frac{1}{2}$ -3 3-4 4-5 in.
Price ...	1/2	1/6	2/2	2/6 3/9 4/9

Steer's Pattern



No. 501w.

Price, with two cutters, $\frac{1}{2}$ -1 $\frac{1}{2}$ in.	12/6
" " " $\frac{1}{2}$ -3 "	16/6
Cutters only	$\frac{1}{2}$ -1	$\frac{1}{2}$ -1 $\frac{1}{2}$	$\frac{1}{2}$ -1 $\frac{1}{2}$	$\frac{1}{2}$ -3 in.
Price	2/6	2/6	2/6	3/-

SET OF 13 G. E. JENNINGS' BITS

All these bits are made of Solid Cast Steel, and are fully warranted.
Price, complete, $\frac{1}{2}$ to 1 in., 42/-



RUSSELL JENNINGS' AUGER BITS

No. 503w.
Sizes: $\frac{1}{2}$, $\frac{3}{8}$, $\frac{1}{2}$, $\frac{5}{8}$, $\frac{3}{4}$, $\frac{7}{8}$, 1 in.
Price, complete in Hardwood Box, 45/-

No. 502w.

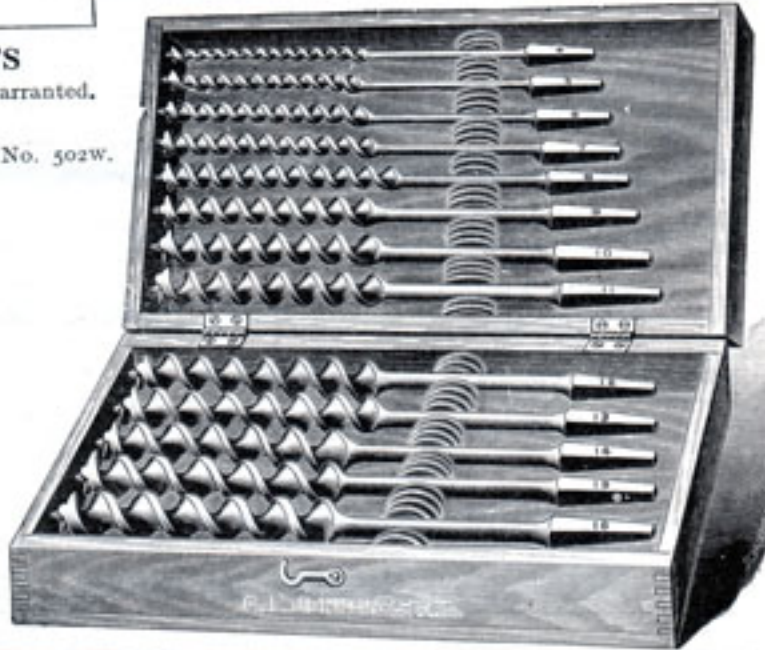

TECHNICAL OUTFIT

No. 504w.

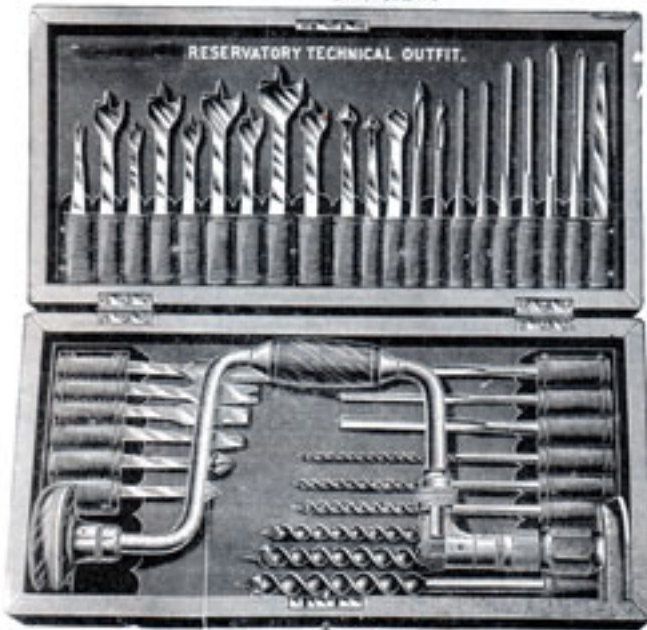

Comprising ball-bearing nickel-plated Brace with 36 specially assorted straw-coloured Bits in polished mortised case fitted with brass lock, handle, and fancy leather pockets. Price, complete 55/-

THE "IRWIN" PATENT AUGER BITS

No. 505w.

It is impossible for these Bits to choke, as they have but one thread, which gives them a clearance double that of the Bits with two threads.

No pressure is required for boring, and they will bore in either the end or the side of the wood.

They are the only Bits made with a SOLID CENTRE, and are therefore much stronger than other Bits.

"IRWIN" PATENT AUGER BITS, IN SETS

Set of 9 "Irwin" Patent Auger Bits, from $\frac{1}{4}$ to 1 in., and one Screwdriver Bit, in patent wooden box.

18/6 per set.

Set of 13 "Irwin" Patent Auger Bits, from $\frac{1}{4}$ to 1 in., \times 16ths, in patent wooden box.

25/- per set.

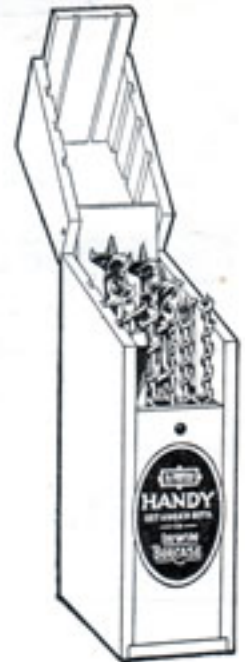

THE "IRWIN" BIT

No. 506w.



Size ...	$\frac{1}{4}$	$\frac{1}{2}$	$\frac{3}{4}$	$\frac{7}{8}$	$\frac{1}{2}$	$\frac{3}{8}$	$\frac{1}{2}$	$\frac{3}{4}$	$\frac{7}{8}$	$\frac{1}{2}$	$\frac{3}{4}$	1 in.
Price ...	1/3	1/3	1/3	1/5	1/6	1/8	1/10	2/1	2/3	2/5	2/6	2/8 2/10 each.

Horticultural and Estate Appliances

BEST CAST STEEL BRACE BITS

CENTRE BIT

No. 507w.



Sets of 12, assorted ... Black. Straw coloured.
Price 6/6 9/6 per set.

IMPROVED CENTRE BIT

No. 509w.

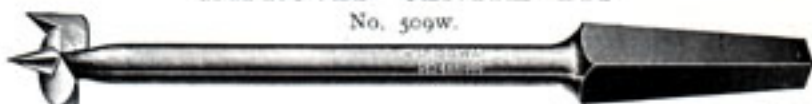

Size ... $\frac{1}{8}$ $\frac{3}{8}$ $\frac{1}{2}$ $\frac{5}{8}$ 1 $1\frac{1}{8}$ $1\frac{1}{4}$ $1\frac{1}{2}$ $1\frac{3}{4}$ 2 in.
Price... -/9 -/9 -/10 -/11 1/- 1/2 1/3 1/9 2/- 2/1 2/3 each.

PRICES, SINGLY, No. 508w.

Size ...	$\frac{1}{8}$	$\frac{3}{8}$	$\frac{1}{2}$	$\frac{5}{8}$	1	$1\frac{1}{8}$	$1\frac{1}{4}$	$1\frac{1}{2}$	$1\frac{3}{4}$	2 in.
Black ...	-/5	-/5	-/6	-/6	-/6½	-/7	-/7½	-/8½	-/10	-/11 1/- 1/2 1/3 1/6 1/8 each.
Straw colour ...	-/7	-/7	-/7	-/8	-/9	-/9½	-/10	-/11 1/- 1/2 1/4 1/5 1/6 1/9 2/- ..		

No. 510w. BIT STOCK DRILL FOR HARDWOOD



Will bore a smooth hole in any direction and will not split the wood nor turn aside from the grain or knots. Speed and feed are entirely under the control of operator.

Size ... $\frac{3}{8}$ $\frac{1}{2}$ $\frac{5}{8}$ 1 $1\frac{1}{8}$ $1\frac{1}{4}$ $1\frac{1}{2}$ $1\frac{3}{4}$ 2 in.
Price ... -/8 -/8 -/9 -/10 1/- 1/2 1/4 1/6 1/9 2/- 2/3 2/6 each.

BRIGHT TWIST BIT

No. 511w.



Size ... $\frac{1}{8}$ $\frac{3}{8}$ $\frac{1}{2}$ $\frac{5}{8}$ 1 $1\frac{1}{8}$ $1\frac{1}{4}$ $1\frac{1}{2}$ in.
Price ... -/4½ -/4½ -/4½ -/4½ -/5 -/5 -/5 each.

Set of 6, assorted to $\frac{1}{2}$ in., 2/2

TAPER BIT FOR WOOD

No. 512w.



Size ... $\frac{1}{8}$ $\frac{3}{8}$ $\frac{1}{2}$ 1 in.
Price ... -/9 -/9 1/- 1/2 1/6 each.

BLACK SPOON BIT

No. 513w.



Size ... $\frac{1}{8}$ $\frac{3}{8}$ $\frac{1}{2}$ $\frac{5}{8}$ 1 $1\frac{1}{8}$ $1\frac{1}{4}$ $1\frac{1}{2}$ in.
Price ... -/6 -/6 -/6 -/7 -/7 -/8 -/10 each.
Sets of 6 to $\frac{1}{2}$ in., 3/-

TURNSCREW BITS



No. 516w.

No. 514w. Black Turn screw Bits.
Size ... $\frac{1}{8}$ $\frac{3}{8}$ $\frac{1}{2}$ 1 in.
Price ... -/5 -/5 -/7 -/9 each.
No. 515w. Bright Round Stem Bits ... -/6 ..

Forked Turn screw Bits, for Saws, etc. etc.
Size ... $\frac{1}{8}$ $\frac{3}{8}$ $\frac{1}{2}$ 1 in.
Price ... -/6 -/6 -/7 -/10 each.

HAND FORGED ROUND SCREWDRIVER BIT

No. 517w.



Length, 5 in., price 1/-; 8 in., price 1/6
This is recommended to stand a great strain.

SMITH'S DRILL

No. 518w.



Black Flat Drill, fitting ordinary Brace.
Size $\frac{1}{8}$, $\frac{3}{8}$, $\frac{1}{2}$, $\frac{5}{8}$, 1 , $1\frac{1}{8}$, $1\frac{1}{4}$, $1\frac{1}{2}$, $1\frac{3}{4}$ in.
Price, all -/6½ each; 6/- per doz.

No. 519w.



RIMERS

Square Rimers -/7 each.

No. 520w.



Half-round Rimers -/7 each.

No. 521w.



Boxwood Handles.

Price 1/6 each

BELLHANGERS' AND ELECTRICIANS' DRILLS



No. 522w.

For bellhangers, car builders, and electricians, also for telephone and telegraph work. It is of the best refined steel, very durable, not injured by contact with nails or screws, and can be driven through plastering and brick walls. It can easily be sharpened on an emery-wheel or a grindstone.

Sizes ...	$12 \times \frac{1}{8}$	$12 \times \frac{3}{8}$	$12 \times \frac{1}{2}$	$12 \times \frac{5}{8}$	$18 \times \frac{1}{2}$	$18 \times \frac{3}{8}$	$18 \times \frac{1}{2}$	$24 \times \frac{1}{8}$	$24 \times \frac{3}{8}$ in.
Price ...	2/6	2/8	3/-	3/3	3/6	3/9	4/-	4/6	4/9 each.

Electric and Wireless Engineers

TOOL AND MACHINE MERCHANTS

COUNTERSINKS

This tool fits any double-cut bit from $\frac{1}{8}$ to $\frac{3}{8}$ in., and by its use countersinking and boring can be done at the same time. It also acts as a gauge. For wood only.

Price 2/- each.

No. 523w.



No. 524w.

NEW PATTERN DOUBLE-LIP COUNTERSINK

The only Double-lip Self-centring Wood Countersink that has a keen cutting edge. It is made from the best steel, forged, twisted, and tempered, and can be sharpened from the inside with a round file.

Price, $\frac{1}{8}$ in., 2/2; $\frac{1}{4}$ in., 2/4 each.

ADJUSTABLE COUNTERSINK

An improved form of Shell Countersink for wood, and is largely used where a number of holes have to be sunk to the same depth, which is regulated by the sliding gauge.

Price 1/10 each. Without gauge, 1/6

No. 525w.



No. 526w. Rose.



No. 527w. Flat.



No. 528w. For Wood.

Size	$\frac{1}{8}$	$\frac{1}{4}$	$\frac{3}{8}$	$\frac{1}{2}$	$\frac{3}{4}$	1 in.
Best Black Rose Countersinks for Metals, etc.	-/6	-/6	-/8	-/11	1/4	1/8 each.
" " Snail " " Wood	-/6	-/6	-/8	-/11	1/4	1/7 ..
" " Flat " " Iron, etc.	-/5 $\frac{1}{2}$	-/5 $\frac{1}{2}$	-/6 $\frac{1}{2}$	-/9	1/2	1/6 ..

REGISTERED SHELL COUNTERSINK

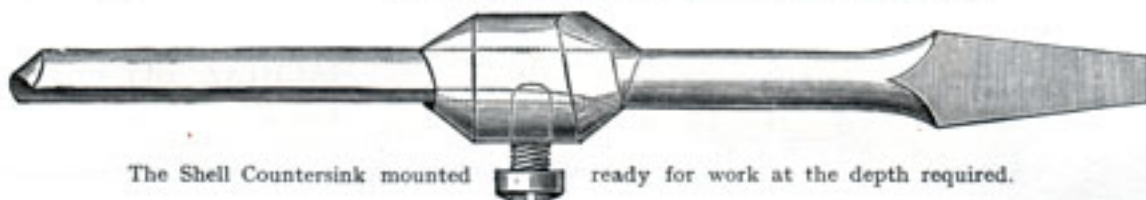

The Shell Countersink mounted ready for work at the depth required.



No. 529w.
The Shell Countersink without Fence.



Side view.

No. 530w.
With Fence to bore the Countersink hole only to the depth required.



End view.

		No. 529w. WITHOUT FENCE			
Size	...	$\frac{1}{8}$	$\frac{1}{4}$	$\frac{3}{8}$	$\frac{1}{2}$ in.
Price...	...	1/6	1/8	1/10	2/- each.
		No. 530w. WITH FENCE			
Size	...	$\frac{1}{8}$	$\frac{1}{4}$	$\frac{3}{8}$	$\frac{1}{2}$ in.
Price...	...	3/2	3/6	5/-	5/6 each.

Prices of larger sizes to $\frac{1}{2}$ in. on application.

BEST CAST STEEL JOINERS' BRACE BITS

No. 531w.

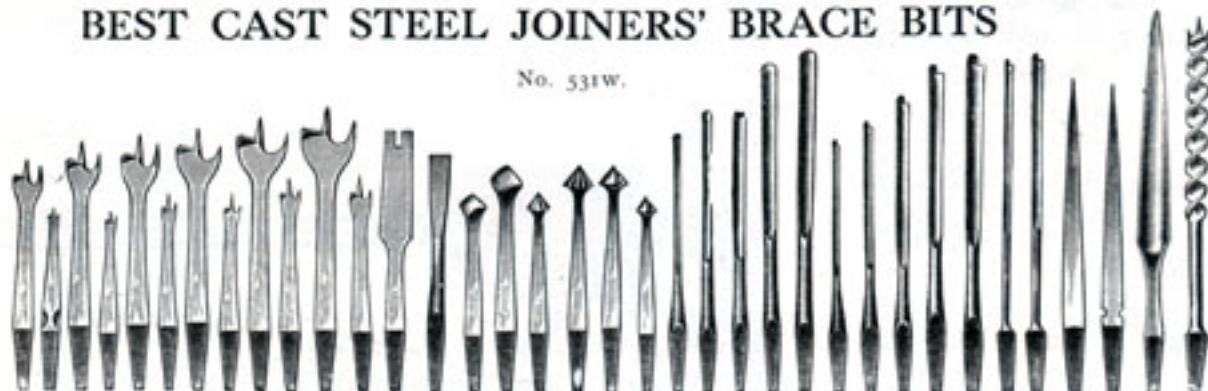

Sets of Assorted Sheffield Brace Bits, Black, price	12	24	36 Bits.
" " " " Bright	6/-	12/-	19/-
" " " " Straw colour, price	6/6	14/-	21/-
				7/-	15/-	24/-

Bronze Medal 1884—Gold Medal 1890

THE "FORSTNER" AUGER BITS

FOR SMOOTH, ROUND, OVAL, OR SQUARE BORING; SCROLL AND TWIST WORK

"One of the Most Remarkable Tools for Woodworking ever Invented."

LABOUR-SAVING AUGER BIT

This, unlike other Bits, is guided by its circular rim instead of its centre, consequently it will bore any arc of a circle, and can be guided in any direction regardless of grain or knots, leaving a true polished surface. It is preferable for core boxes, fine and delicate patterns, veneers, screen work, fancy scroll-twist columns, newels, ribbon moulding, etc.



TO SHARPEN THE BIT

Take a hard three-cornered file, grind smooth at front end, thus making a three-cornered scraper; scrape inside of flange until sharp, and take off outside wire edge with oilstone. File the cutters with small fine-cut file. FOR VERY SMOOTH WORK, take the edge off, so as to form a very slight bevel on outside edge of flange, always being careful to have the flange project a little beyond the cutters.

BRACE BIT

No. 532w.



$\frac{1}{4}$	$\frac{5}{16}$	$\frac{3}{8}$	$\frac{7}{16}$	$\frac{1}{2}$	$\frac{9}{16}$	$\frac{5}{8}$	$\frac{11}{16}$	in
4/2	4/2	4/6	4/6	5/-	5/4	5/4	5/6	ea.
$\frac{3}{4}$	$\frac{13}{16}$	$\frac{7}{8}$	$\frac{15}{16}$	1	$1\frac{1}{16}$	$1\frac{1}{8}$	$1\frac{3}{8}$	in
6/-	6/6	6/6	7/10	7/10	8/3	8/3	9/-	ea.
$1\frac{1}{4}$	$1\frac{1}{8}$	$1\frac{1}{2}$	$1\frac{1}{2}$	$1\frac{1}{2}$	$1\frac{3}{4}$	$1\frac{3}{4}$	2	in.
10/-	10/-	10/9	13/9	14/-	15/6	16/6	17/6	ea.

$\frac{1}{4}$	$\frac{5}{16}$	$\frac{3}{8}$	$\frac{7}{16}$	$\frac{1}{2}$	$\frac{9}{16}$	$\frac{5}{8}$	$\frac{11}{16}$	in.
5/-	5/-	5/6	5/6	5/9	6/3	6/3	6/6	ea.
$\frac{3}{4}$	$\frac{13}{16}$	$\frac{7}{8}$	$\frac{15}{16}$	1	$1\frac{1}{16}$	$1\frac{1}{8}$	$1\frac{3}{8}$	in.
7/-	7/6	7/6	8/9	8/9	9/3	9/3	10/-	ea.
$1\frac{1}{4}$	$1\frac{1}{8}$	$1\frac{1}{2}$	$1\frac{1}{2}$	$1\frac{1}{2}$	$1\frac{3}{4}$	$1\frac{3}{4}$	2	in.
11/-	11/3	11/6	14/6	15/3	16/6	17/6	18/9	ea.

MACHINE BIT

No. 533w.

With $\frac{1}{2}$ in. shanks.

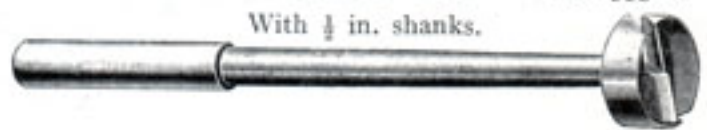

The $\frac{1}{4}$ in. and $\frac{5}{16}$ in. Bits have Spiral Shanks.

ANTI-FRICTION BIT DEPTH GAUGES

No. 534w.



This Gauge is provided with a large steel ball which revolves as it comes in contact with the work. The object of this ball is to prevent defacing delicate or polished work. Price 1/9.



No. 535w.

This Depth Gauge runs exactly parallel to the auger bit and projects sufficiently to clear any size of chuck.

Japanned and polished ... 1/9 each.



No. 49

A Stop is placed on both sides of the bit, and when the proper depth is reached the bit remains upright and does not bend or break the worm.

Can be attached to any bit up to 1 in. diameter.

No. 536w ... 3/4 each.



No. 537w.

As will be seen by the illustration, the Gauge is secured to the bit at any point by the use of a clamp, actuated by two thumb nuts. The entire tool is Nickel-plated.

Price ... 1/3 each.

TOOL AND MACHINE MERCHANTS

COUNTERSINKS AND DRILLS

No. 538w.

For woodworking machines.
For boring and countersinking at one operation.

Centre Bits can be supplied when required, in place of the Drills, at same prices, if ordered specially.



Diam. of Hole.	Diam. of Countersink.	Price. Countersink only.	Price. Drill only.	Overall Length of Countersink.	Diam. of Shank.	Diam. of Hole.	Diam. of Countersink.	Price. Countersink only.	Price. Drill only.	Overall Length of Countersink.	Diam. of Shank.
1/2 in.	1 in.	7/3	1/1	3 in.	1/2 in.	3/8 in.	1 in.	9/-	2/2	4 in.	1/2 in.
3/8 in.	3/4 in.	7/3	1/1	3 "	3/8 in.	1/2 in.	1 1/4 in.	9/-	2/9	4 "	3/8 in.
1/4 in.	3/8 in.	7/3	1/2	3 "	1/4 in.	3/8 in.	1 1/2 in.	9/10	2/9	4 "	1/4 in.
3/16 in.	1/4 in.	7/3	1/5	3 "	3/16 in.	1/4 in.	1 3/4 in.	9/10	3/2	4 "	3/16 in.
1/8 in.	3/16 in.	7/3	1/5	3 "	1/8 in.	3/16 in.	1 7/8 in.	12/-	3/4	4 "	1/8 in.
3/32 in.	1/8 in.	8/-	1/10	3 1/2 "	3/32 in.	1/8 in.	2 in.	12/-	3/9	4 "	3/32 in.
1/32 in.	3/32 in.	8/-	1/11	3 1/2 "	1/32 in.	3/32 in.	2 1/8 in.				1/32 in.

DOVETAILING BITS

No. 539w.

For woodworking machines.

These are made with double cutting edges of a shear-cut form, and thereby are much stronger than tools with other shapes of flutes. They can be made for right- or left-hand working, but will be supplied right-handed unless specially mentioned.



Four sizes of these tools are stocked, as shown below, but special sizes of dovetailing bits can be made to order if in minimum quantities of one dozen of a size.

Size Number.	Largest Diameter of Fluted Part.	Smallest Diameter of Fluted Part.	Diameter of Shank.	Exact length between Large and Small Diameters.	Length Overall.	Price.
1	1/2 in.	3/8 in.	1/4 in.	1/4 in.	3 1/2 in.	4/- each.
2	3/4 in.	1/2 in.	3/8 in.	3/8 in.	3 3/4 in.	5/- "
3	1 in.	3/4 in.	1/2 in.	1/2 in.	3 7/8 in.	6/6 "
4	1 1/8 in.	1 in.	5/8 in.	5/8 in.	4 in.	7/6 "



PLUG CUTTERS

No. 540w.

This is intended to cut a plug of wood to cover the head of the screw on finely finished work, etc.

Size	1/2 in.
Price	2/4 each.

SET OF NINE BIT STOCK DRILLS

No. 541w.

For Wood.

Cutting 1/8 to 1/2 in.
Price complete, 11/-



No. 542w.

LIP AND SPUR BIT FOR WOOD

Size	1 in.
Price	1/10	2/3	2/8	3/2	3/7	4/-	5/-	6/-	7/-	8/-	8/6	9/6	11/-	13/-	14/- each.

BRAD PUNCHES AND NAIL SETS, ASSORTED

No. 543w. No. 544w. No. 545w.

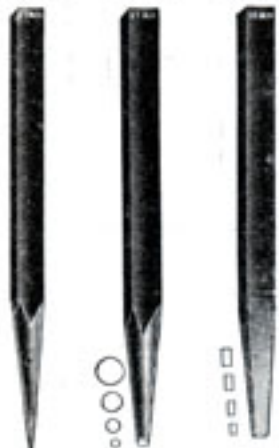

Price -/3 1/4 each, any shape.
No. 546w. Set of 6 assorted, 1/6

SPECIAL QUALITY NAIL SETS

No. 547w.

Made of a fine grade of steel with knurled centres, hardened ends, oval tops, and concave tips.

Length, 4 in.
Diameters at tips, 1/8, 3/16, 1/4, and 5/16 in.
Price -/8 each.

TWELVE PUNCHES

No. 548w.

In wooden box, assorted.
1/8, 3/16, and 1/4 in.
Price 7/6 set.



No. 549w. Extra heavy.
Punch ... 1/8 1/4 in.
Price ... -/10 1/- each.

POCKET SET OF HIGH-GRADE NAIL SETS

No. 550w.

Consisting of one each of 1/8, 3/16, 1/4, and 5/16, put up in a convenient pocket case, as illustrated.

Price 3/6 per set.

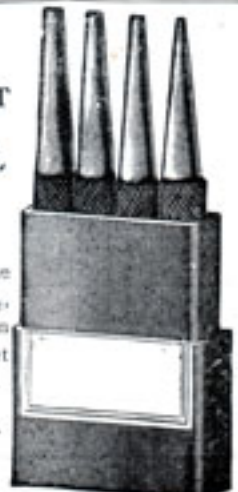

WOOD SLOTTING BITS



PRICES OF SLOTTING BITS WITH SHANKS SAME DIAMETER AS BITS. No. 551W.

Diameter of Bit.	Full Length.	Length of Shank.	Price, each.	Diameter of Bit.	Full Length.	Length of Shank.	Price, each.	Diameter of Bit.	Full Length.	Length of Shank.	Price, each.
In. $\frac{1}{8}$	3	1 $\frac{1}{2}$	1/6	In. $\frac{1}{4}$	5 $\frac{1}{2}$	1 $\frac{1}{2}$	4/8	In. $\frac{1}{2}$	8	2	10/4
$\frac{1}{4}$	3 $\frac{1}{2}$	1 $\frac{1}{2}$	1/6	$\frac{3}{8}$	5 $\frac{1}{2}$	1 $\frac{1}{2}$	4/8	$\frac{1}{2}$	8 $\frac{1}{2}$	2 $\frac{1}{2}$	13/4
$\frac{3}{8}$	3 $\frac{3}{4}$	1 $\frac{1}{2}$	2/-	$\frac{1}{2}$	6	2	5/-	$\frac{3}{4}$	9	2 $\frac{1}{2}$	17/6
$\frac{1}{2}$	3 $\frac{3}{4}$	1 $\frac{1}{2}$	2/-	$\frac{5}{8}$	6 $\frac{1}{2}$	2	5/9	$\frac{7}{8}$	9 $\frac{1}{2}$	2 $\frac{3}{4}$	20/6
$\frac{5}{8}$	4	1 $\frac{1}{2}$	3/-	$\frac{3}{4}$	6 $\frac{1}{2}$	2	6/3	$\frac{1}{2}$	10	2 $\frac{3}{4}$	25/-
$\frac{3}{4}$	4 $\frac{1}{4}$	1 $\frac{1}{2}$	3/-	$\frac{7}{8}$	6 $\frac{1}{2}$	2	6/8	$\frac{1}{2}$	10 $\frac{1}{2}$	3	31/-
$\frac{7}{8}$	4 $\frac{1}{4}$	1 $\frac{1}{2}$	3/6	1	7	2	7/3	$\frac{1}{2}$	11	3	37/-
1	4 $\frac{1}{2}$	1 $\frac{1}{2}$	3/6	$\frac{1}{8}$	7 $\frac{1}{2}$	2	7/9	1 $\frac{1}{2}$	11 $\frac{1}{2}$	4	43/6
$\frac{1}{8}$	5	1 $\frac{1}{2}$	4/-	$\frac{1}{4}$	7 $\frac{1}{2}$	2	8/3	2	12	4	52/-
$\frac{1}{4}$	5 $\frac{1}{2}$	1 $\frac{1}{2}$	4/-	$\frac{3}{8}$	7 $\frac{1}{2}$	2	9/4				

PRICES OF SLOTTING BITS WITH $\frac{1}{2}$ INCH SHANKS. No. 552W.

Diameter of Bit.	Full Length.	Length of Shank.	Price, each.	Diameter of Bit.	Full Length.	Length of Shank.	Price, each.	Diameter of Bit.	Full Length.	Length of Shank.	Price, each.
In. $\frac{1}{8}$	3	1 $\frac{1}{2}$	2/8	In. $\frac{1}{4}$	4 $\frac{1}{2}$	1 $\frac{1}{2}$	4/-	In. $\frac{3}{8}$	6 $\frac{1}{2}$	2	6/3
$\frac{1}{4}$	3 $\frac{1}{2}$	1 $\frac{1}{2}$	2/8	$\frac{3}{8}$	5	1 $\frac{1}{2}$	4/-	$\frac{1}{2}$	6 $\frac{1}{2}$	2	6/8
$\frac{3}{8}$	3 $\frac{3}{4}$	1 $\frac{1}{2}$	3/-	$\frac{1}{2}$	5 $\frac{1}{2}$	1 $\frac{1}{2}$	4/4	$\frac{3}{4}$	7	2	7/4
$\frac{1}{2}$	3 $\frac{3}{4}$	1 $\frac{1}{2}$	3/-	$\frac{5}{8}$	5 $\frac{1}{2}$	1 $\frac{1}{2}$	4/8	$\frac{1}{2}$	7 $\frac{1}{2}$	2	8/-
$\frac{3}{4}$	4	1 $\frac{1}{2}$	3/9	$\frac{3}{4}$	5 $\frac{1}{2}$	1 $\frac{1}{2}$	4/8	$\frac{7}{8}$	7 $\frac{1}{2}$	2	8/3
1	4 $\frac{1}{4}$	1 $\frac{1}{2}$	3/9	$\frac{1}{2}$	6	2	5/-	$\frac{1}{2}$	7 $\frac{1}{2}$	2	9/4
$\frac{1}{8}$	4 $\frac{1}{4}$	1 $\frac{1}{2}$	4/-	$\frac{3}{8}$	6 $\frac{1}{2}$	2	5/8	1	8	2	10/3

STRAIGHT FLUTED CENTRE BITS



PRICES OF CENTRE BITS WITH SHANKS SAME DIAMETER AS BITS. No. 553W.

Diameter of Bit.	Full Length.	Length of Shank.	Price, each.	Diameter of Bit.	Full Length.	Length of Shank.	Price, each.	Diameter of Bit.	Full Length.	Length of Shank.	Price, each.
In. $\frac{1}{8}$	3	1 $\frac{1}{2}$	1/1	In. $\frac{1}{4}$	5 $\frac{1}{2}$	1 $\frac{1}{2}$	3/1	In. $\frac{1}{2}$	11	2 $\frac{1}{2}$	14/-
$\frac{1}{4}$	3 $\frac{1}{2}$	1 $\frac{1}{2}$	1/1	$\frac{3}{8}$	5 $\frac{1}{2}$	1 $\frac{1}{2}$	3/4	$\frac{1}{2}$	11 $\frac{1}{2}$	2 $\frac{1}{2}$	17/6
$\frac{3}{8}$	3 $\frac{3}{4}$	1 $\frac{1}{2}$	1/2	$\frac{1}{2}$	6	1 $\frac{1}{2}$	3/11	$\frac{3}{4}$	12 $\frac{1}{2}$	2 $\frac{3}{4}$	20/-
$\frac{1}{2}$	3 $\frac{3}{4}$	1 $\frac{1}{2}$	1/5	$\frac{5}{8}$	8	2	5/-	$\frac{1}{2}$	14 $\frac{1}{2}$	3	25/6
$\frac{3}{4}$	4	1 $\frac{1}{2}$	1/5	$\frac{3}{4}$	8 $\frac{1}{2}$	2	6/2	$\frac{1}{2}$	15	3	31/-
1	4 $\frac{1}{4}$	1 $\frac{1}{2}$	1/8	$\frac{7}{8}$	9	2	7/-	$\frac{1}{2}$	15 $\frac{1}{2}$	3 $\frac{1}{2}$	37/-
$\frac{1}{8}$	4 $\frac{1}{4}$	1 $\frac{1}{2}$	1/10	1	9 $\frac{1}{2}$	2 $\frac{1}{2}$	8/4	$\frac{1}{2}$	16	3 $\frac{3}{4}$	43/-
$\frac{1}{4}$	4 $\frac{1}{2}$	1 $\frac{1}{2}$	2/2	$\frac{1}{8}$	10	2 $\frac{1}{2}$	9/9	$\frac{1}{2}$	16 $\frac{1}{2}$	4	49/6
$\frac{1}{4}$	5	1 $\frac{1}{2}$	2/8	$\frac{3}{8}$	10 $\frac{1}{2}$	2 $\frac{1}{2}$	11/3	2	16 $\frac{1}{2}$	4	57/-
$\frac{3}{8}$	5 $\frac{1}{2}$	1 $\frac{1}{2}$	2/9	$\frac{1}{4}$	10 $\frac{1}{2}$	2 $\frac{1}{2}$	12/-				

PRICES OF CENTRE BITS WITH $\frac{1}{2}$ INCH SHANKS. No. 554W.

Diameter of Bit.	Full Length.	Length of Shank.	Price, each.	Diameter of Bit.	Full Length.	Length of Shank.	Price, each.	Diameter of Bit.	Full Length.	Length of Shank.	Price, each.
In. $\frac{1}{8}$	3	1 $\frac{1}{2}$	1/6	In. $\frac{1}{4}$	4 $\frac{1}{2}$	1 $\frac{1}{2}$	2/5	In. $\frac{3}{8}$	6	1 $\frac{1}{2}$	3/9
$\frac{1}{4}$	3 $\frac{1}{2}$	1 $\frac{1}{2}$	1/6	$\frac{3}{8}$	4 $\frac{1}{2}$	1 $\frac{1}{2}$	2/10	$\frac{1}{2}$	8	2	5/2
$\frac{3}{8}$	3 $\frac{3}{4}$	1 $\frac{1}{2}$	1/8	$\frac{1}{2}$	5	1 $\frac{1}{2}$	3/-	$\frac{3}{4}$	8 $\frac{1}{2}$	2	6/2
$\frac{1}{2}$	3 $\frac{3}{4}$	1 $\frac{1}{2}$	1/10	$\frac{5}{8}$	5 $\frac{1}{2}$	1 $\frac{1}{2}$	3/3	$\frac{1}{2}$	9	2	7/-
$\frac{3}{4}$	4	1 $\frac{1}{2}$	2/-	$\frac{3}{4}$	5 $\frac{1}{2}$	1 $\frac{1}{2}$	3/4	$\frac{1}{2}$	9 $\frac{1}{2}$	2 $\frac{1}{2}$	8/6
1	4 $\frac{1}{4}$	1 $\frac{1}{2}$	2/2	$\frac{7}{8}$	5 $\frac{1}{2}$	1 $\frac{1}{2}$	3/7				

Horticultural and Estate Appliances

TOOL AND MACHINE MERCHANTS

HOLLOW AUGERS

This will cut all sizes from $\frac{1}{4}$ to $1\frac{1}{4}$ in. diameter. In moving for different sizes no alteration of the knife is necessary, the change being made by simply turning the thumbscrew in the rack.

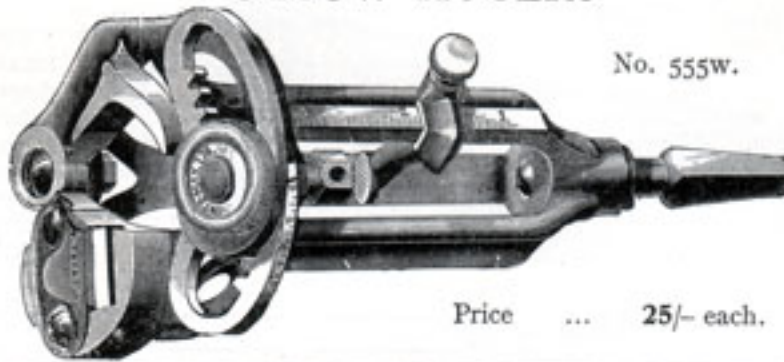

No. 555w.

It is provided with an adjustable stop, or depth gauge, sliding on a rule-marked scale, by means of which the length of tenon cut can be regulated exact, from 1 to 3 in.

Price ... 25/- each.

IMPROVED SPOKE TRIMMER

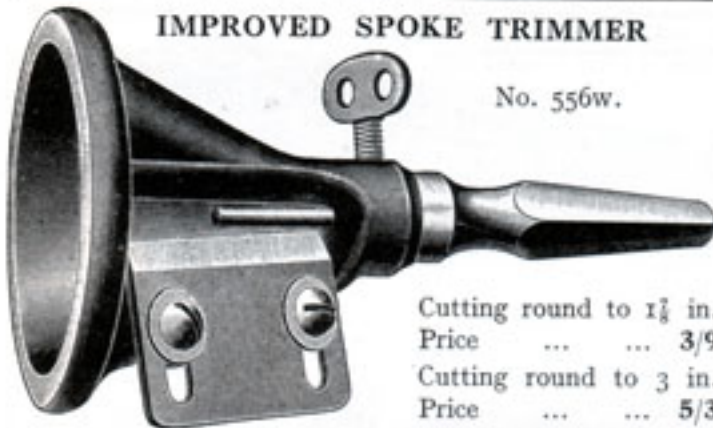

No. 556w.

Cutting round to $1\frac{1}{8}$ in.
 Price ... 3/9
 Cutting round to 3 in.
 Price ... 5/3

THE UNIVERSAL

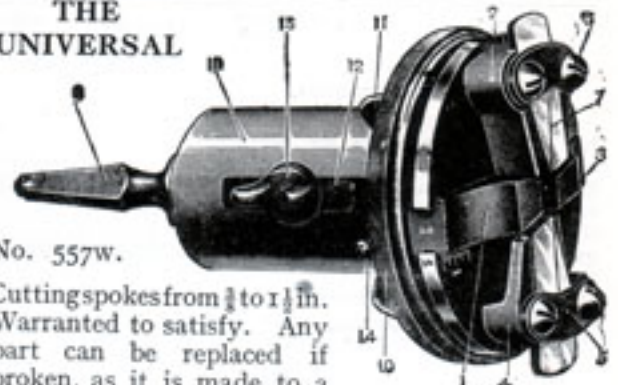

No. 557w.

Cutting spokes from $\frac{3}{8}$ to $1\frac{1}{8}$ in. Warranted to satisfy. Any part can be replaced if broken, as it is made to a gauge. Price 33/- Extra cutters, 4/- per pair.

No. 558w.

AMES' IMPROVED HOLLOW AUGER

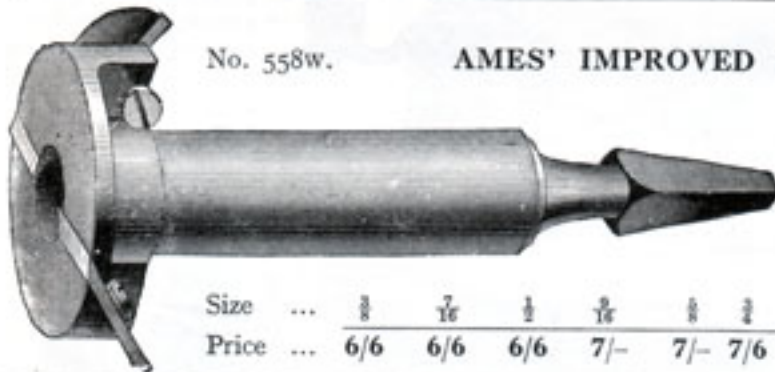

This shows the well-known non-expanding type.

Extra cutters, 4/6 per pair.

Size ...	$\frac{3}{8}$	$\frac{7}{8}$	$\frac{1}{2}$	$\frac{3}{4}$	$\frac{1}{2}$	$\frac{3}{4}$	$\frac{1}{2}$	1	$1\frac{1}{2}$	$1\frac{1}{2}$	$1\frac{1}{2}$	$1\frac{1}{2}$	in.
Price ...	6/6	6/6	6/6	7/-	7/-	7/6	8/6	9/6	10/9	11/6	13/-	13/6	each.

AWARDS FOR EXCELLENCE OF TOOLS AND MACHINES

BRONZE MEDAL 1884



GOLD MEDAL 1890

Adjustable from $1\frac{1}{8}$ to $1\frac{1}{2}$ in. full. Does not cut smaller than $1\frac{1}{8}$ in. nor larger than $1\frac{1}{2}$ in. full.

Easily and quickly adjusted. Screws and wearing parts hardened. Patent Stop and Knife Clamp. Simple, durable, and accurate.

THE ADJUSTABLE HOLLOW AUGER

No. 559w.

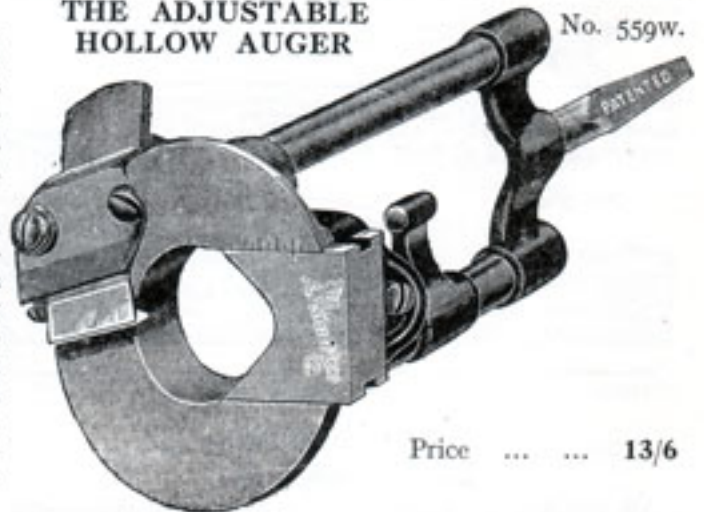

Price ... 13/6

Electric and Wireless Engineers

RICHARD MELHUISH LIMITED, LONDON, E.C.

BEST QUALITY CAST AND VANADIUM STEEL SAWS

No. 560w.

Melhuish's New Skew Back Saws. All bearing our name.



The blade is ground thinner at back than front, and has a peculiar shaped butt or heel, which enables a full sweep of the Saw to be given without the possibility of catching in the work. The handle is of polished Beech, and is firmly secured to the blade by improved nickel-plated screws.

Length	20	22	24	26	28	in.
Price	9/-	9/9	10/9	11/9	12/-	each.

With ordinary handles. Handles with thumb holes as drawn.

LONDON PATTERN HAND SAWS

Fully Warranted.

The sterling quality of these Saws has secured for them an extensive adoption amongst first-class workmen throughout the country. Special attention is given to the tempering and finishing of the blades, which are ground about 4 gauges thinner at back than front.

Length	...	18	20	22	24	26	28	in.
Best quality	...	7/6	8/-	8/9	9/6	10/6	11/3	each.

No. 561w.

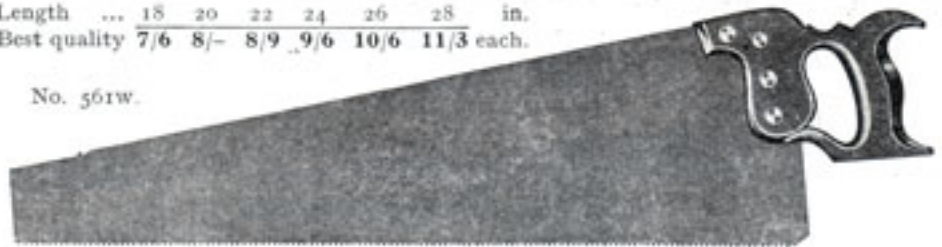

Size	...	20	22	24	26	28	in.
Price	...	10/3	11/3	13/3	14/3	15/6	each.

No. 562w.

Warranted Silver Spring Steel, improved temper, mirror finish, selected English Beech handles polished all over.

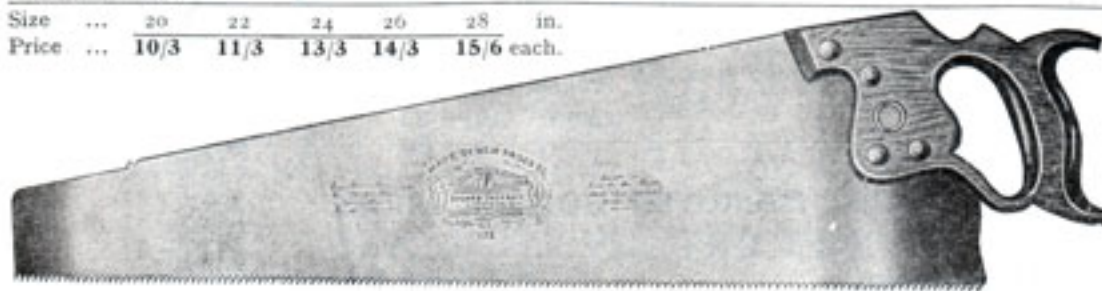

Size	...	20	22	24	26	28	in.
Standard sizes of teeth	...	10-12	10-12	6, 7, 8	5, 5½, 6, 6½, 7, 8	3½, 4	points to inch.
Skew back	...	10/6	11/6	13/6	14/6	16/6	each

No. 563w.

This Saw answers to the same description as No. 562w above, but has skew instead of straight back.

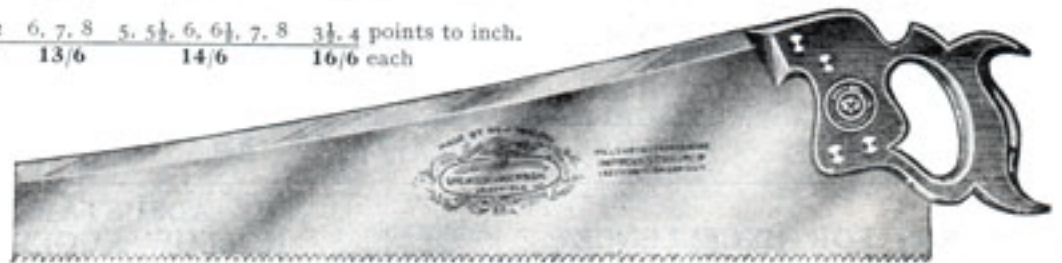

Size	...	20	22	24	26	28	in.
Skew back	...	16/-	17/-	17/9	18/9	20/3	each.

Standard of teeth as above.

No. 564w



Vanadium Alloy Steel, improved temper, mirror polish, carved Hardwood handles, polished all over, raised brass screws.

These Saws are the best that can possibly be made, regardless of price. The blade is made from a secret alloy of Vanadium Steel, of great toughness, and will work longer than any other saw without sharpening, being at the same time more difficult to buckle in use.

Attention is requested to the following when ordering :

Six points  or tops.

All our Saws are stamped the number of points—not teeth—to the inch (see example). Kindly order accordingly.

We endeavour to keep in stock the following points in the best quality Saws.

20 in. Panel	...	—	—	—	10	11	12
22 " "	...	—	—	—	10	11	12
24 " "	...	7	8	9	10	—	—
26 " Hand	...	5	5½	6	7	8	—
28 " Rip	...	—	3	3½	4	—	—

Bronze Medal 1884—Gold Medal 1890

TOOL AND MACHINE MERCHANTS

DISSTON'S AND OTHER AMERICAN SAWS

This is the original Skewback Saw, and has proved to be one of the most popular saws in the world. Skewback, refined Crucible Steel blade, warranted, Apple handle, full polished, Brass screws.

(DISSTON'S NO. D8)

No. 565w.

These Saws have all the latest improvements in hand saws, and are warranted. They combine the popular "Skewback," the peculiar shaped butt or heel which, with the new screws, makes it almost impossible to work loose from the handle, and gives the full sweep of the Saw without the possibility of catching in the work.



Length	20	22	24	26	28	in.
Price	11/8	12/6	13/6	14/2	16/2	each.

(DISSTON'S NO. 7)

No. 566w.



Every Saw bearing the brand of Disston is guaranteed to be as true and as free from flaws as it is possible to make it.

With warranted Crucible Steel blade, polished edge, and Beech handle.

Length	20	22	24	26	in.
Price	10/2	11/3	11/10	12/6	each.

Extra refined London Spring Steel, selected and highly polished blade, warranted, Apple handle, carved and polished, Brass screws.

(DISSTON'S NO. 12)

No. 567w.

One of the finest Saws made.

Lgth.	20	22	24	26	28	in.
Price	14/6	15/10	17/2	18/5	20/-	ea.



(DISSTON'S NO. D17)

No. 568w.



Skewback, refined Crucible Steel blade, warranted, Hardwood handle, full polished, Brass screws.

The combination of teeth in this Saw, alternate sections of five regular cross-cutting teeth and two ripping teeth, separated by numerous deep gullets for full clearance, ensures free running, easy, very rapid, and clean cutting in heavy work, whether cross-cutting or ripping, and especially for sawing diagonally across the grain, as its name implies.

Price, in 26 in. only ... 15/3

This Saw is particularly adapted for general construction work of all kinds.

"ATKINS" CELEBRATED SAWS

THE "ATKINS" SILVER STEEL SAWS. Perfection handle, polished Applewood, not carved.

The blades of these celebrated Saws are manufactured from a special fine tool steel capable of high temper and taking a keen cutting edge without crumbling. The teeth hold their set longer and do more work without filing than other saws. The blades are ground so carefully from teeth to back and from point to handle that they would not bind even if worked without set. Special attention is called to the forms of the blade and the handle, whereby the Saw conforms to and balances well in the grasp of the hand, and enables full cutting force to be given the entire length of the blade.

No. 569w.



No. 570w.



This pattern is introduced to meet the demand for a Straight Back Saw but with Plain "Perfection" Handle. Many carpenters appreciate the merits of this handle and have asked for it on a straight back blade.

Size	20	22	24	26	28	in.
No. 569w. Skewback	10/6	11/3	12/3	12/9	14/6	each.
" 570w. Straight back	10/6	11/3	12/3	12/9	14/6	"
Points, per inch	9-12	8-12	6-10	5-8	3 1/2-5	"

Engineers' Tools and Machinery

RICHARD MELHUISE LIMITED, LONDON, E.C.

Best quality Cast Steel Hand Saw with Lightning Tooth. Of special temper and strength, and particularly adapted for cutting rough wood.

LIGHTNING TOOTH SAW

No. 571w.

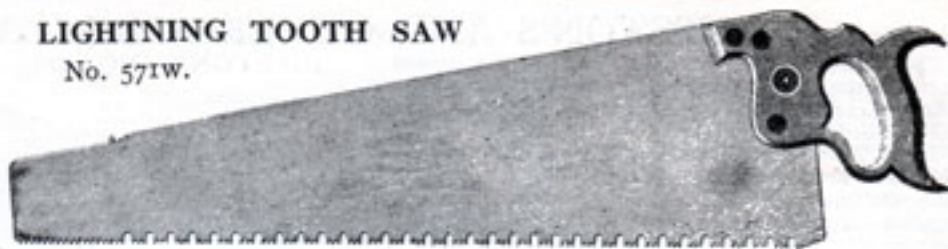

Length, 26 in.
 Price 12/6
 Second quality 7/6

NEST OF SAWS

No. 572w.

Price complete 3/-
 Comprising Keyhole, Compass, and Pruning Saw Blades.



PRUNING SAW

No. 573w.

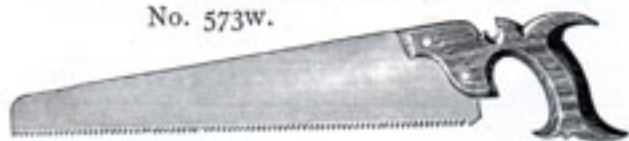

Length ... 18 20 22 24 in.
 Price ... 5/6 6/- 6/3 7/- each.

BEST COMPASS SAWS

No. 574w.



Length ... 12 14 16 18 in.
 Price ... 2/9 3/- 3/3 3/6 each.

We are stocking Saws shown below as a sequel to the many demands for a cheaper quality. We wish it to be understood that they are not first-class goods, but are warranted quality and temper, and where they are not required for continual and hard use, they will give satisfaction.

No. 575w.



TWO-MEN CROSS-CUT SAW

Length 4 5 6 ft.
 Price 9/- 11/- 11/6 each.

No. 576w.

ONE-MAN CROSS-CUT SAW

Length ... 2½ 3 4 ft.
 Price ... 7/6 9/- 12/- each.
 Supplementary handle, 1/-



No. 577w.

SPECIAL TOOTH SAW

Suitable for farmers and others. Recommended for cutting rough wood.

Length, 26 in.

Price 5/6



No. 578w.

This Saw is suitable for the amateur and is not recommended for constant hard work.



Length 12 14 16 18 20 22 24 in.
 Price 2/9 3/- 3/3 3/6 4/- 4/3 4/6 each.

Builders' and Furnishing Ironmongery

TOOL AND MACHINE MERCHANTS

ONE AND TWO MEN CROSS-CUT SAWS

ENGLISH AND AMERICAN.

No. 579w.
English
Manu-
facture.



Cast
Steel.
Best
quality.
Peg
Teeth.

Length, 5 ft., price 14/- | 5½ ft., price 15/- | 6 ft., price 18/- | 7 ft., price 21/- each. Handles 1/6 per pair extra.

No. 580w.

English
Manufacture.



Length, 5 ft., price 16/- | 5½ ft., price 18/- | 6 ft., price 21/- | 7 ft., price 25/- each. Handles 1/9 per pair extra.
Lightning Teeth, cutting both ways.

DISSTON'S GREAT AMERICAN CROSS-CUT SAWS.

No. 581w.



Length, 5 ft., price 25/- | 5½ ft., price 27/6 | 6 ft., price 30/- | 7 ft., price 35/- each. Handles 1/9 per pair extra.

TRIUMPH GREAT AMERICAN. Width at centre, 3¼ in.

No. 582w.

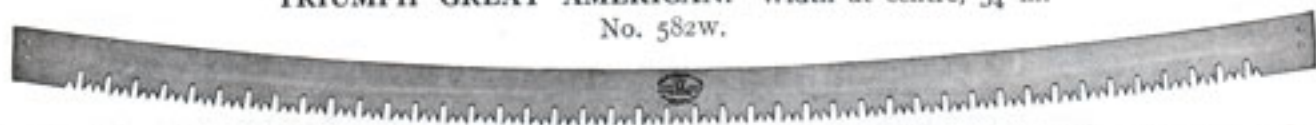

Length, 4 ft., price 11/3 | 5 ft., price 14/- | 6 ft., price 17/- | 7 ft., price 19/9 each. Handles 1/9 per pair extra.

No. 583w.

Disston's
Make.

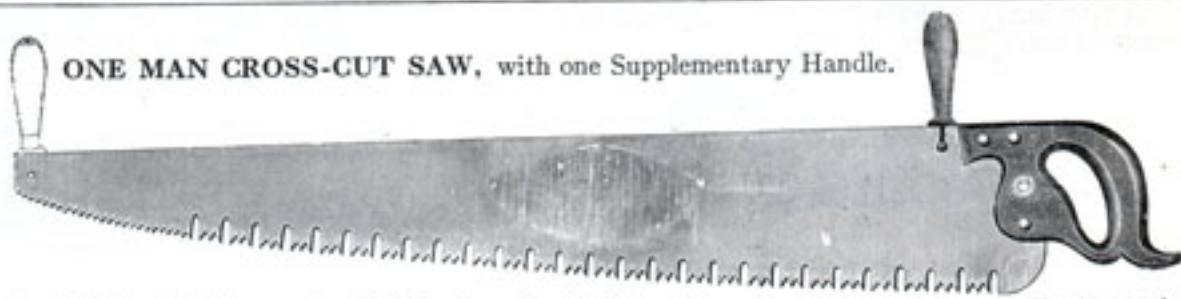

ONE MAN CROSS-CUT SAW, with one Supplementary Handle.

Length, 3 ft., price 15/9 | 3 ft. 6 in., price 18/3 | 4 ft., price 20/9 | 5 ft., price 26/- Extra handle 1/- each.

CAST STEEL, ENGLISH PATTERN.

No. 584w.



Length, 3 ft., price 12/- | 3 ft. 6 in., price 13/6 | 4 ft., price 16/- | 5 ft., price 21/- Extra handle 1/- each.

WARRANTED CAST STEEL PIT SAWS. Of English Manufacture.

No. 585w.

Sharpening and
Setting -4 per foot
extra.



Length, 5 ft., price 18/6 | 6 ft., price 22/6 | 7 ft., price 26/-.

Horticultural and Estate Appliances

SHEFFIELD DOVETAIL AND TENON SAWS

HEAVY PATTERN, IRON BACK No. 588w.

No. 586w.

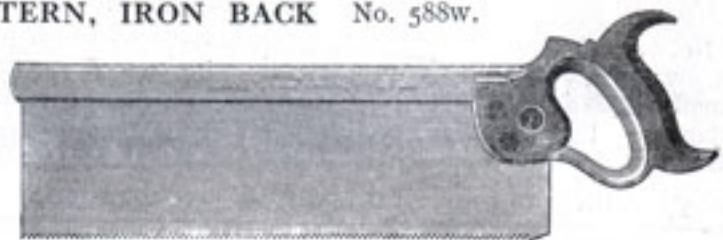

Size	8	9	10	in.
Price	6/-	6/3	6/6	each.
No. 587w.	2nd quality	4/6	4/9	5/-	..	

Size	12	14	16	in.
Price	7/6	8/-	9/-	each.
No. 589w.	2nd quality	5/6	6/-	6/6	..	

HEAVY PATTERN, BRASS BACK

No. 590w.



No. 592w.



Size	12	14	16	in.
Price	10/-	11/-	13/-	each.
No. 591w.	2nd quality	8/6	9/6	11/9	..	

Size	8	9	10	in.
Price	8/6	8/6	8/6	each.
No. 593w.	2nd quality	7/3	7/3	7/3	..	

LIGHT PATTERN

No. 594w.

A very handy Saw for household purposes. Not for constant use.



Size	8	10	12	in.
Price	4/-	4/2	4/6	each.

PATENT ADJUSTABLE TENON SAW

No. 595w.

By reversing lever, blade can be moved up and down. When adjusted to depth of tenon, etc., tighten lever and adjust by nut.

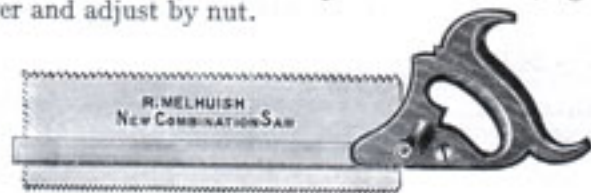

Length of blade, 12 in. Price 13/6

HENRY DISSTON & SONS' STEEL AND BRASS BACK SAWS



Of the first quality, with Applewood handles, with polished edges.

Size	8	10	12	14	16	in.
No. 596w.	With Blued Steel Backs	8/3	8/9	10/-	11/3	12/6	ea.	
No. 597w.	With Brass Backs	11/6	12/3	13/6	14/6	16/9	..	

E. C. ATKINS' SILVER STEEL BACK SAWS

Size	8	10	12	14	in.
No. 598w.	Iron Back	8/3	8/9	10/-	11/3	each.	
..	599w. Brass Back	11/6	12/3	13/6	14/6	..	



TOOL AND MACHINE MERCHANTS

NEW PATTERN

PAD SAW

No. 600w.
Beech handle.
Length of blade, 12 in.
Price, complete ... 2/3



PAD SAW HANDLES

No. 601w.
Small Beech ... price 1/2
Large " ... 1/8
Small Box ... 2/-
Large Ebony ... 3/-

For Blades, see page 57.

ELECTRICIAN'S SAW

No. 603w.
Price for Wood ... 1/-
.. Metal ... 1/-

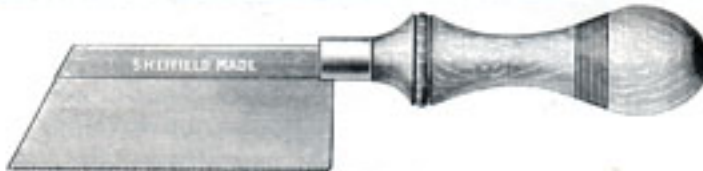

THIS
SHEFFIELD
MADE
COPING
SAW

complete with
1 doz. Blades.

PRICE

1/6
complete.



IRON HANDLE LOCKING PAD SAW

Length of blade, 11 in. No. 604w. Price ... 1/6



No. 605w.
This is an excellent little tool for watchmakers, jewellers, and mechanics. One extra blade for wood and one for iron is supplied with every Saw.
Price ... 2/-

BACK SAWS (for Wood)

No. 606w.



Length	...	4	5	6	8 in.
Price	...	1/-	1/3	1/6	1/9

Disston's make, 8 in. only, 5/-

PIERCING SAW (for Metal)

Size 2 1/2 in. deep.
Price ... 3/-



No. 607w.

MACHINE BANDSAWS FOR HARD AND SOFT WOODS

UNIFORM THROUGHOUT IN TEMPER, WIDTH, AND GAUGE.

Brazed, set, and sharpened ready for use.

It is impossible for us to warrant saws against cracks, as it is well known there are many causes for these Saws cracking which are entirely beyond the control of the maker. Should the cracks be caused from faulty material or defective workmanship on our part our warranty applies.

No. 608w.



It is advisable when placing a wide saw on the machine to see that it is run light without cutting for an hour or so to remove any surplus elasticity, and to afterwards examine for tension and correct the loss of tension that almost invariably ensues.

	1/2	3/4	1	1 1/4	1 1/2	1 3/4	2	2 1/4	2 1/2	2 3/4	3	3 1/4	3 1/2	3 3/4	4	4 1/4	4 1/2	4 3/4	5	5 1/4	5 1/2	5 3/4	6	6 1/4	6 1/2	6 3/4	7	7 1/4	7 1/2	7 3/4	8	8 1/4	8 1/2	8 3/4	9	9 1/4	9 1/2	9 3/4	10	10 1/4	10 1/2	10 3/4	11	11 1/4	11 1/2	11 3/4	12	12 1/4	12 1/2	12 3/4	13	13 1/4	13 1/2	13 3/4	14	14 1/4	14 1/2	14 3/4	15	15 1/4	15 1/2	15 3/4	16	16 1/4	16 1/2	16 3/4	17	17 1/4	17 1/2	17 3/4	18	18 1/4	18 1/2	18 3/4	19	19 1/4	19 1/2	19 3/4	20	20 1/4	20 1/2	20 3/4	21	21 1/4	21 1/2	21 3/4	22	22 1/4	22 1/2	22 3/4	23	23 1/4	23 1/2	23 3/4	24	24 1/4	24 1/2	24 3/4	25	25 1/4	25 1/2	25 3/4	26	26 1/4	26 1/2	26 3/4	27	27 1/4	27 1/2	27 3/4	28	28 1/4	28 1/2	28 3/4	29	29 1/4	29 1/2	29 3/4	30	30 1/4	30 1/2	30 3/4	31	31 1/4	31 1/2	31 3/4	32	32 1/4	32 1/2	32 3/4	33	33 1/4	33 1/2	33 3/4	34	34 1/4	34 1/2	34 3/4	35	35 1/4	35 1/2	35 3/4	36	36 1/4	36 1/2	36 3/4	37	37 1/4	37 1/2	37 3/4	38	38 1/4	38 1/2	38 3/4	39	39 1/4	39 1/2	39 3/4	40	40 1/4	40 1/2	40 3/4	41	41 1/4	41 1/2	41 3/4	42	42 1/4	42 1/2	42 3/4	43	43 1/4	43 1/2	43 3/4	44	44 1/4	44 1/2	44 3/4	45	45 1/4	45 1/2	45 3/4	46	46 1/4	46 1/2	46 3/4	47	47 1/4	47 1/2	47 3/4	48	48 1/4	48 1/2	48 3/4	49	49 1/4	49 1/2	49 3/4	50	50 1/4	50 1/2	50 3/4	51	51 1/4	51 1/2	51 3/4	52	52 1/4	52 1/2	52 3/4	53	53 1/4	53 1/2	53 3/4	54	54 1/4	54 1/2	54 3/4	55	55 1/4	55 1/2	55 3/4	56	56 1/4	56 1/2	56 3/4	57	57 1/4	57 1/2	57 3/4	58	58 1/4	58 1/2	58 3/4	59	59 1/4	59 1/2	59 3/4	60	60 1/4	60 1/2	60 3/4	61	61 1/4	61 1/2	61 3/4	62	62 1/4	62 1/2	62 3/4	63	63 1/4	63 1/2	63 3/4	64	64 1/4	64 1/2	64 3/4	65	65 1/4	65 1/2	65 3/4	66	66 1/4	66 1/2	66 3/4	67	67 1/4	67 1/2	67 3/4	68	68 1/4	68 1/2	68 3/4	69	69 1/4	69 1/2	69 3/4	70	70 1/4	70 1/2	70 3/4	71	71 1/4	71 1/2	71 3/4	72	72 1/4	72 1/2	72 3/4	73	73 1/4	73 1/2	73 3/4	74	74 1/4	74 1/2	74 3/4	75	75 1/4	75 1/2	75 3/4	76	76 1/4	76 1/2	76 3/4	77	77 1/4	77 1/2	77 3/4	78	78 1/4	78 1/2	78 3/4	79	79 1/4	79 1/2	79 3/4	80	80 1/4	80 1/2	80 3/4	81	81 1/4	81 1/2	81 3/4	82	82 1/4	82 1/2	82 3/4	83	83 1/4	83 1/2	83 3/4	84	84 1/4	84 1/2	84 3/4	85	85 1/4	85 1/2	85 3/4	86	86 1/4	86 1/2	86 3/4	87	87 1/4	87 1/2	87 3/4	88	88 1/4	88 1/2	88 3/4	89	89 1/4	89 1/2	89 3/4	90	90 1/4	90 1/2	90 3/4	91	91 1/4	91 1/2	91 3/4	92	92 1/4	92 1/2	92 3/4	93	93 1/4	93 1/2	93 3/4	94	94 1/4	94 1/2	94 3/4	95	95 1/4	95 1/2	95 3/4	96	96 1/4	96 1/2	96 3/4	97	97 1/4	97 1/2	97 3/4	98	98 1/4	98 1/2	98 3/4	99	99 1/4	99 1/2	99 3/4	100	100 1/4	100 1/2	100 3/4
--	-----	-----	---	-------	-------	-------	---	-------	-------	-------	---	-------	-------	-------	---	-------	-------	-------	---	-------	-------	-------	---	-------	-------	-------	---	-------	-------	-------	---	-------	-------	-------	---	-------	-------	-------	----	--------	--------	--------	----	--------	--------	--------	----	--------	--------	--------	----	--------	--------	--------	----	--------	--------	--------	----	--------	--------	--------	----	--------	--------	--------	----	--------	--------	--------	----	--------	--------	--------	----	--------	--------	--------	----	--------	--------	--------	----	--------	--------	--------	----	--------	--------	--------	----	--------	--------	--------	----	--------	--------	--------	----	--------	--------	--------	----	--------	--------	--------	----	--------	--------	--------	----	--------	--------	--------	----	--------	--------	--------	----	--------	--------	--------	----	--------	--------	--------	----	--------	--------	--------	----	--------	--------	--------	----	--------	--------	--------	----	--------	--------	--------	----	--------	--------	--------	----	--------	--------	--------	----	--------	--------	--------	----	--------	--------	--------	----	--------	--------	--------	----	--------	--------	--------	----	--------	--------	--------	----	--------	--------	--------	----	--------	--------	--------	----	--------	--------	--------	----	--------	--------	--------	----	--------	--------	--------	----	--------	--------	--------	----	--------	--------	--------	----	--------	--------	--------	----	--------	--------	--------	----	--------	--------	--------	----	--------	--------	--------	----	--------	--------	--------	----	--------	--------	--------	----	--------	--------	--------	----	--------	--------	--------	----	--------	--------	--------	----	--------	--------	--------	----	--------	--------	--------	----	--------	--------	--------	----	--------	--------	--------	----	--------	--------	--------	----	--------	--------	--------	----	--------	--------	--------	----	--------	--------	--------	----	--------	--------	--------	----	--------	--------	--------	----	--------	--------	--------	----	--------	--------	--------	----	--------	--------	--------	----	--------	--------	--------	----	--------	--------	--------	----	--------	--------	--------	----	--------	--------	--------	----	--------	--------	--------	----	--------	--------	--------	----	--------	--------	--------	----	--------	--------	--------	----	--------	--------	--------	----	--------	--------	--------	----	--------	--------	--------	----	--------	--------	--------	----	--------	--------	--------	----	--------	--------	--------	----	--------	--------	--------	----	--------	--------	--------	----	--------	--------	--------	----	--------	--------	--------	----	--------	--------	--------	----	--------	--------	--------	----	--------	--------	--------	----	--------	--------	--------	----	--------	--------	--------	----	--------	--------	--------	----	--------	--------	--------	----	--------	--------	--------	----	--------	--------	--------	----	--------	--------	--------	-----	---------	---------	---------

BAND SAWS, for cutting Cold Steel and other metals, brazed, set, and sharpened ready for use.
No. 609w.
Price ... 2/- 2/3 2/3 2/9 3/- 3/3 4/3 5/- 5/9 6/9 7/6 per yard.
Supplied in long coils when required.

Bronze Medal 1884—Gold Medal 1890

CIRCULAR SAWS FOR WOOD

No. 610W.

Best Warranted Cast Steel. Machine ground. When ordering, give gauge, diameter of spindle and pin hole (state distance between them), pattern of tooth, and distance from point to point.

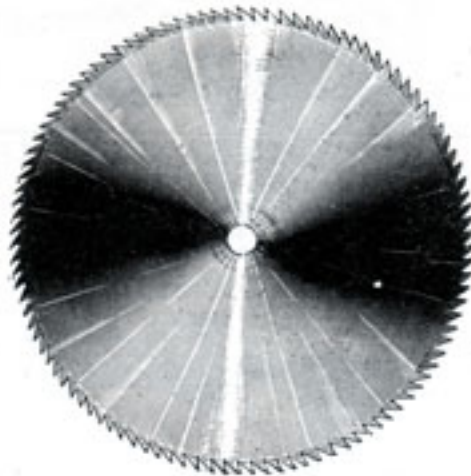

Say also whether required for hard or soft wood.

For patterns of Teeth, see illustration below.

Size	...	3	4	5	6	7	8	10	12	14	16	18	20	22	24	26	28	30	36	48	in.
Gauge	...	22	22	21	20	19	19	18	17	17	16	15	14	14	13	13	12	12	11	—	
Price	...	3/-	3/-	3/9	4/9	5/6	6/9	8/6	10/6	13/6	15/-	17/6	21/6	25/-	28/-	32/-	38/-	43/6	70/-	153/-	ea.

Sharpening Saws ready for immediate use, -/2 per in. extra.

Special Quotations for Larger Sizes on application.

Each letter from A to N indicates the pitch of a Saw Tooth.

Estimates for Saw Mill Requisites and Complete Sawing Plants for Export.

Experienced packers employed in the dispatch of all our goods.

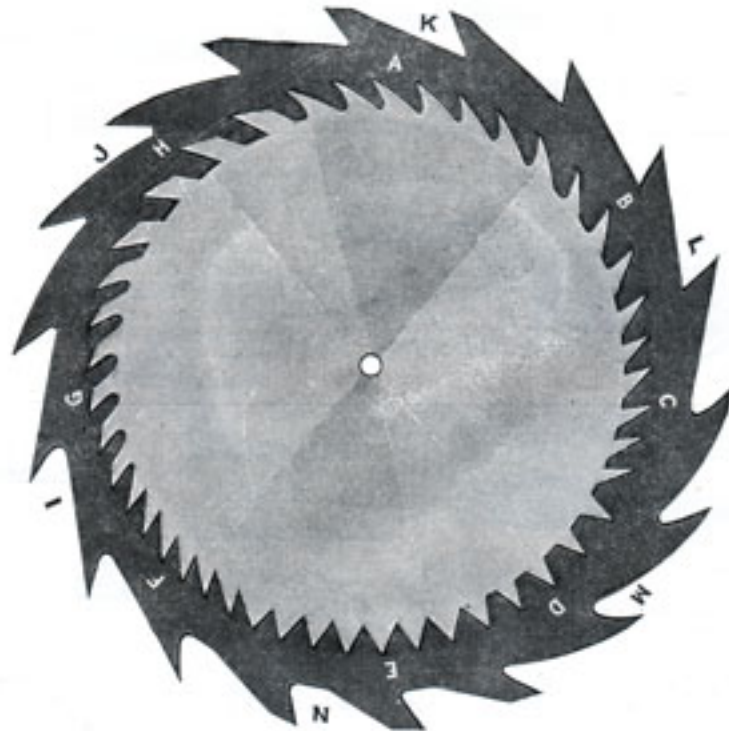

Special attention given to every detail in Fittings, and care in marking each part for putting together in working order when delivered.

For Metal Saws, see our Engineers' Catalogue.

CAST STEEL GROOVING SAWS

No. 611W.

MACHINE GROUND

Thickness	...	$\frac{1}{8}$	$\frac{3}{16}$	$\frac{1}{4}$	$\frac{5}{16}$	$\frac{3}{8}$	$\frac{7}{16}$	in.
Price	...	2/2	3/-	3/3	3/3	3/6	4/-	per in. diam.
Thickness	...	$\frac{1}{2}$	$\frac{3}{8}$	$\frac{5}{8}$	$\frac{1}{2}$	$\frac{3}{4}$	1	in.
Price	...	4/3	5/-	5/3	5/6	5/9	6/-	per in. diam.



TOOL AND MACHINE MERCHANTS

BOW SAW
BLADES Length 8 10 12 14 16 in.
 No. 612w. Price $-\frac{3}{4}$ $-\frac{3}{4}$ $-\frac{3}{4}$ $-\frac{3}{4}$ $-\frac{3}{4}$ each.

PAD SAW
BLADES To 12 in., $-\frac{3}{4}$; 13 in., $-\frac{3}{4}$ each.
 No. 613w. Special Blued, $-\frac{3}{4}$ each.

CAST STEEL MILL SAW WEBS



No. 614w.
 We supply these from 3 to 10 ft. long and 3 to 10 in. in width. Kindly send particulars and we shall be pleased to quote.

DISSTON'S MITRE BOX SAWS No. 615w.

Crucible Steel blades, Apple handles. They are all 11 points to the inch and 19 gauge in thickness. Saws 5 and 6 in. deep may be had. Prices on application.
 Length of Blade 20 22 24 26 x 4 in. deep.
 Price ... 16/6 18/- 20/- 21/- each.



SIDE REBATE PLANE
 No. 616w.



Combined right- and left-hand.
 Nickelled, with Rosewood knob.
 Price 8/6 each.

VIOLIN MAKERS' PLANES
 No. 617w.

Made in Gun-metal. With round and flat faces, one plain and one toothed iron to each.

Width of Iron $\frac{5}{8}$ $\frac{7}{8}$ $\frac{9}{8}$ in.
 Flat face ... 7/- 7/3 8/- ea.
 Round ... 7/3 8/- 9/9 ea.

Width of Iron $\frac{1}{2}$ $\frac{3}{4}$ in.
 Flat face ... 10/- 12/6 ea.
 Round ... 11/9 13/6 ..

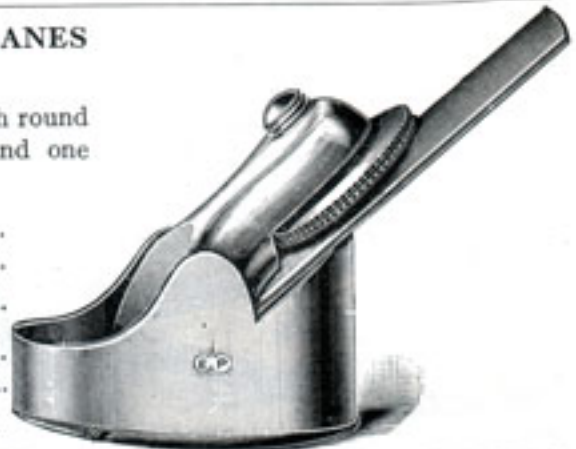

UNBREAKABLE BRACE BIT HOLDER



FULL SIZE
 Price, finished Blue colour, 1/- each.
 Accommodates any size Brace Bit without filing or notching.

BIT ROLL No. 619w.
 Brown Canvas.

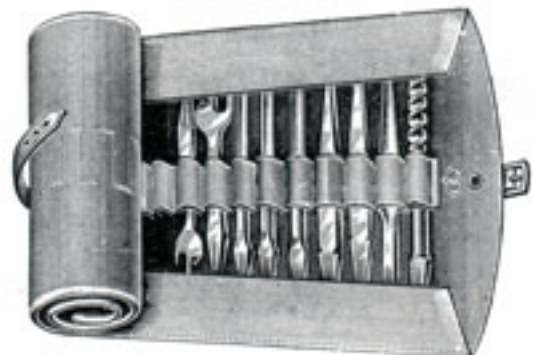

To hold 36 Bits ... 4/6 each.
 Ditto, Baize lined ... 6/- ..
 No. 620w. In Leather ... 6/- ..

STANLEY BUTT GAUGE For Rebated Jamb.



Cutter A marks from the jamb in the rebate—Cutter B from the edge of the door engaged in closing—Cutter C the thickness of the butt. It can also be used as a Marking and Mortise Gauge and as an inside or outside Square for squaring the edge of the butt on either door or jamb. In hanging doors there are three measurements to be marked—the location of butt on the casing, the location of butt on the door, and the thickness of butts on both casing and door. STANLEY BUTT GAUGES have three separate cutters arranged with the necessary clearances so that no change of setting is necessary when hanging a number of doors. They are also Rebate Gauges, Marking Gauges, and Mortise Gauges, and have a scope sufficient for all door trim, including lock plates, strike plates, etc.

Nickel-plated. graduated in 16ths in. for 2 in., 6/6 each.

Builders' and Furnishing Ironmongery

DISSTON'S TRIUMPH SET

The idea embodied in this Saw Set is one that will commend itself to every user of a saw-setting tool. The principal feature is the use of two plungers operated by the two levers or handles; pressure on the lower lever forcing plunger D against the body of the saw, thus holding it rigidly in position and preventing slipping, whilst a continuation of the pressure on the upper lever operates plunger C in setting the tooth.

In action it is easy and powerful, and while it will perfectly set wide and heavy saws, it is also particularly adapted for narrow blades, such as web saws, narrow band saws, etc. If the gauge B is properly adjusted, the result will be a uniformity of set that cannot be obtained by any other hand set.

No. 622w/8. For Cross-cut and Circular Saws. Price 11/-
 No. 623w/280. For Saws 10-16 points. Price 6/-



No. 624w/28. For ordinary Saws. Price 6/-
 No. 625w/18. For small Circular Saws. Price 8/-



**PATENT
BRONZED
PUNCH
SAW SET**

No. 626w.
Price 12/6 each.

**STANLEY SAW
SET**

"PISTOL GRIP."

The shape of the body and handle enables the user to operate the tool with great ease, as the saw set is held in a comfortable and natural position. The saw is held firmly against the gauge while the tooth is being set.

The saw teeth are in plain view, which enables the user to quickly adjust the tool to the tooth to be set.

Black finish ... price 9/- each.

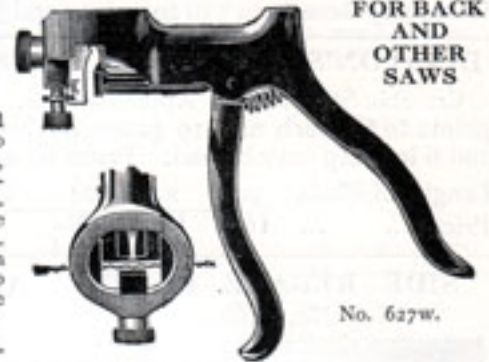

**FOR BACK
AND
OTHER
SAWS**

No. 627w.

PLIER SAW SET

No. 628w.

Oxidised. Length, 7 in. Price 4/6 each.



DISSTON'S BRASS SAW SCREWS

No. 629w.

No. 630w.

No. 631w.



Length ... $\frac{1}{2} \times \frac{1}{2}$ $\frac{1}{2} \times \frac{3}{4}$ $\frac{1}{2} \times \frac{1}{2}$ $\frac{1}{2} \times 1$ in. across head.
 Price ... -/3 -/4 -/5 -/6 each.

No. 632w. Screws for English Saws, -/3 each.

**SAW VICE
WITH
BALL
AND
SOCKET
CLAMP**

No. 633w.

By the use of this Clamp, a saw can be held straight or at any angle the operator may desire.

Length of jaw, 9 in.
Price, 13/- each.



**SAW VICE
WITH
HINGE
PATTERN
CLAMP**

No. 634w.

Length of jaw, 9 1/2 in.

Price 9/6 each.



**SAW
FILER'S
VICE AND
GUIDE**

No. 635w.

This is especially designed to assist those not skilled in the art of saw filing to file a saw correctly.

Length of jaw, 12 1/2 in. Weight complete, 7 lb.

Price, as illustrated, 19/6 each.

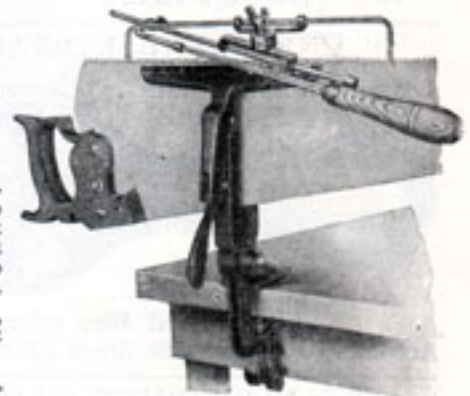

**WOOD SAW
BUCK**

No. 636w.

Strong and well finished. Most useful.

Price ... 4/6 each.



TURNING SAWS AND FRAMES

No. 637w.

All polished Beech.

Length 10 12 14 16 in.
 Price 7/6 8/3 9/- 10/6 each.

Blades only.

Price -/3 1/2 -/4 -/4 1/2 -/6 each.
 .. 3/3 3/9 4/3 5/9 per doz.

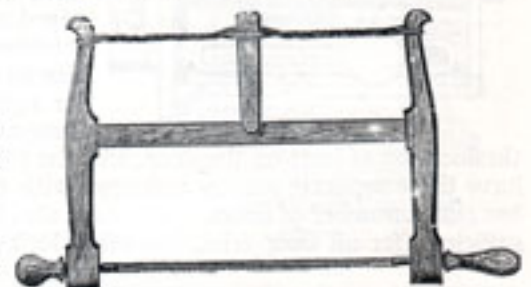

TOOL AND MACHINE MERCHANTS

SAW SETS



No. 638w. Price 1/3 No. 639w. With guard, 2/3



No. 640w. All Steel. Price 1/3 No. 641w. Heavy pattern, 3/3

MORRILL'S PATTERN (English Make)



No. 642w.

Polished bright price 4/6

STEARNS' PATTERN



No. 643w.

Suitable for Saws to 16 gauge price 3/6

MORRILL'S "SPECIAL"



No. 644w.

**"SPECIAL"
SAWSET**

"SPECIAL," with rotatable fully indexed anvil, for hand, band, jig, butcher, and fret saws $\frac{1}{2}$ in. or over in width, not over 16 gauge. This is provided with a lock nut, preventing screw from turning. Length, 6 $\frac{1}{2}$ in. price 6/-

MORRILL'S NO. 1



No. 645w.

**NO. 1.
SAWSET**

For hand, band, jig, butcher, and all saws $\frac{1}{2}$ in. wide and over, not over 16 gauge. Length, 6 $\frac{1}{2}$ in. price 6/-

No. 646w.



**NO 3
SAWSET**

With sliding anvil and pointed plunger for cross-cut and circular saws, single tooth, 14-20 gauge. Length, 9 $\frac{1}{2}$ in. price 8/6

No. 647w.



**NO 5
SAWSET**

With sliding anvil, for timber and board saws from 6 to 14 gauge. Cast finished. Length, 15 in. price 12/6



No. 648w/2 price 4/10
" 649w/12 " 6/10
" 650w/20 " 10/5

DISSTON'S "MONARCH"

First adjust the anvil so that the bevel most suitable for the size tooth to be set is brought into position; hand the Saw Set on the saw so that the guide "B" rests on the teeth; adjust this guide for the depth of set to be given by use of set screw "A." Use care not to go too deeply into the body of the tooth, as all of the set should be in the point itself. Taking too deep a hold is likely to distort the body of the blade or break out the teeth. The top of plunger "D" should be in line with the top of the tooth to be set. Next adjust the set screw for amount of set required, taking care not to put on any more set than is absolutely necessary. If these instructions as to adjustment are carried out, the results will be entirely satisfactory to the operator.

The "Monarch" Saw Set is adapted for setting saws $\frac{1}{2}$ in. and wider. Made in three sizes; the smaller size, No. 648w/2, being suitable for hand saws, back saws, etc., the medium, No. 649w/12, and large, No. 650w/20, sizes for circular, cross-cut saws, etc.

Electric and Wireless Engineers

BEST QUALITY JOINERS' SQUARES

ROSEWOOD PLATED
No. 651w.

Size	4½	6	7½	9	12	in.
Price	2/4	2/9	3/4	4/-	5/3	each.



EBONY SHIELD PLATED
No. 652w

Size	4½	6	7½	9	12	in.
Price	2/10	3/4	4/-	4/9	6/3	each.



ROSEWOOD TRY AND MITRE
No. 653w.

Size ...	4½	6	7½	9	12	in.
Price ...	3/6	4/-	4/9	5/4	6/9	each.



ROSE MITRE
No. 654w.

Length ...	8	10	12	in.
Price ...	4/3	5/-	5/6	each.



ROSE AND EBONY BEVELS
No. 655w.

Best Plated Rosewood Stock
Best Plated Ebony Stock ...



ROSE AND EBONY BEVELS
No. 656w.

Length ...	9	10½	12	in.
Price ...	4/3	4/6	5/-	each.
Price ...	4/6	4/9	5/3	..



TRY AND MITRE
No. 657w.

Length	4	6	8	in.
Price ...	2/1	2/6	3/-	each.
Length	10	12	in.	
Price ...	3/7	4/2	each.	

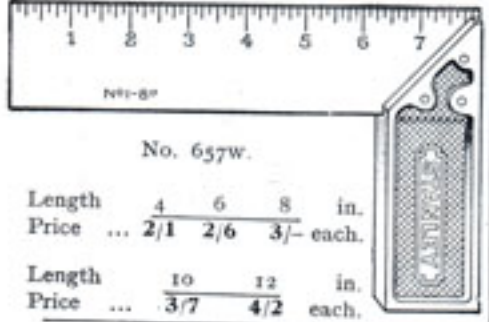

STANLEY IRON SQUARES
TRY SQUARE
No. 658w.

Iron handle, Nickel-plated. Graduated 8ths, 16ths.

Length, 4 in., 2/6; 6 in., 2/10 each.

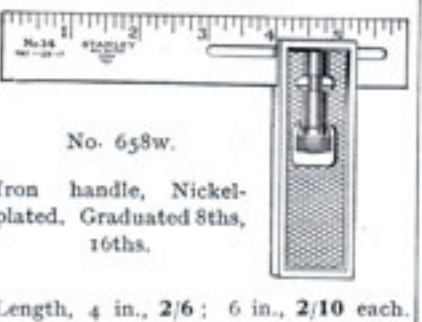

NICKEL-PLATED STOCK
No. 659w.

Length	4	6	8	10	12	in.
Price	1/10	2/4	2/8	3/4	4/2	each.

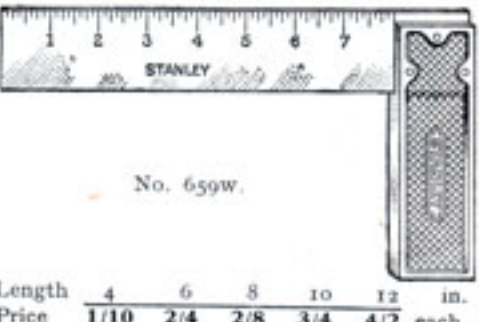

NICKEL-PLATED BEVEL
No. 660w.

With locking device

Length of blade ...	6	8	10	in.
Price ...	3/-	3/6	3/11	each.

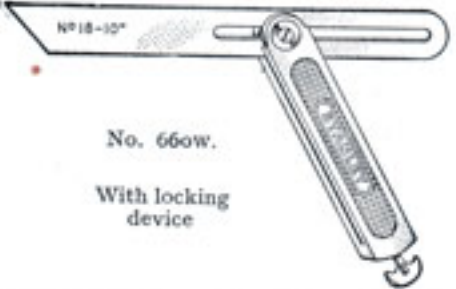

IRON MITRE SQUARES
No. 661w.

Iron handle, Nickel-plated. The blade is set at an angle of 45°.

Length of blade ...	8	10	12	in.
Price ...	3/1	3/8	4/2	each.

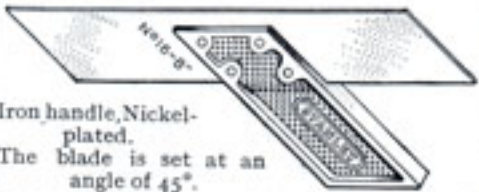

COMBINATION TRY AND MITRE SQUARE
No. 662w.

Iron handle, Nickel-plated. Graduated 8ths, 16ths, 32nds.

Length of blade	6	9	12	in.
Price ...	3/10	4/6	5/2	each.

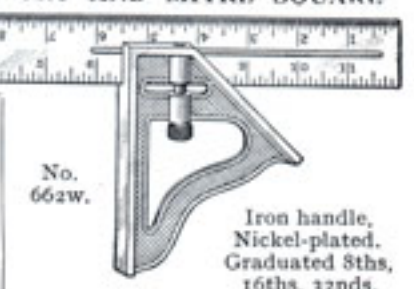

"ODD JOBS"
No. 663w.

It combines a Level, Plumb, Try Square, Mitre Square, Bevel, Scratch Awl, Depth Gauge, Marking Gauge, Mortise Gauge, Beam Compass, and a One-foot Rule. The rule is graduated in sixteenths of inches. All parts of the tool are carefully machined, so that in using same for any purpose where any of the above-mentioned tools are required sufficient accuracy may be obtained for all practical purposes.

Length, 4 in., Nickel-plated ... price 5/8 each.



BOAT BUILDER'S BEVEL
Two Brass Tongues.
No. 664w.

Length, 12 in. ... price 2/6 each



Bronze Medal 1884—Gold Medal 1890

STANLEY STEEL SQUARES

No.	Body.		Tongue.		Markings.	Particulars.	Finish.	Price.
	In.	In.	In.	In.				
No. 665w.	24 × 2	18 × 1½	☆. ☆. 1/8. 1/8. 1/8	☆. ☆. 1/8. 1/8. 1/8	Brace, Octagon, Essex Board Measure, and 100th Scale	Polished	9/3	
.. 666w.	24 × 2	18 × 1½	1/8. 1/8. 1/8. 1/8. 1/8	1/8. 1/8. 1/8. 1/8. 1/8	Ditto.	Blued	11/6	
.. 667w.	24 × 2	18 × 1½	☆. ☆. 1/8. 1/8. 1/8	☆. ☆. 1/8. 1/8. 1/8	Brace and Essex Board Measure	Polished	8/4	
.. 668w.	24 × 2	18 × 1½	☆. ☆. 1/8. 1/8. 1/8	☆. ☆. 1/8. 1/8. 1/8	" " " "	Blued	10/7	
.. 669w.	18 × 1½	12 × 1	☆. ☆. 1/8. 1/8. 1/8	☆. ☆. 1/8. 1/8. 1/8	" " " "	Polished	7/5	
.. 670w.	12 × 1½	8 × 1	1/8. 1/8. 1/8. 1/8. 1/8	1/8. 1/8. 1/8. 1/8. 1/8	" " " "	"	5/7	

RAFTER OR FRAMING SQUARE

No. 671w.	24 × 2	18 × 1½	☆. ☆. 1/8. 1/8. 1/8	☆. ☆. 1/8. 1/8. 1/8	Brace, Octagon, Essex Board Measure, and 100th Scale	Polished	11/9
.. 672w.	24 × 2	18 × 1½	☆. ☆. 1/8. 1/8. 1/8	☆. ☆. 1/8. 1/8. 1/8	Brace and Essex Board Measure	"	9/3

Complete details of the method of using these tables will be found in a booklet which is packed with each Square.

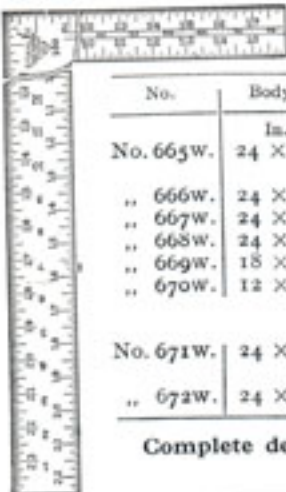
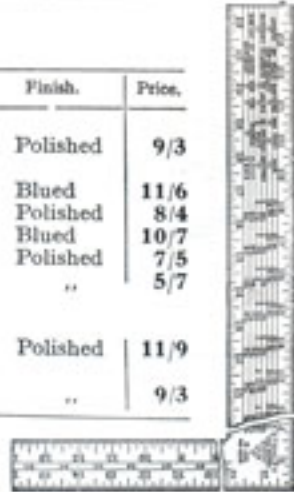

STANLEY ANGLE DIVIDERS

No. 673w.

To lay out the cut bisecting an angle with an ordinary bevel necessitates the use of dividers and a second handling of the bevel, making three operations. The Stanley Angle Divider is designed for performing this work at one setting and is practically a double bevel. The two blades each fit one side of an angle and the handle gives the centre line. The cut is marked from the centre.

The handle is graduated on the under side for laying out four-, six-, or eight-sided work, and, by means of a removable "T" head, it can also be used as a "T" square.

Price 8/9 each.

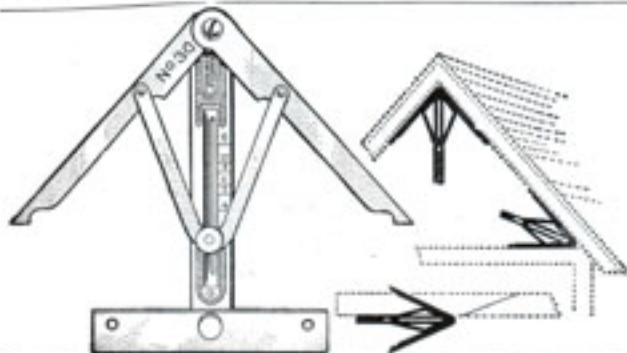

PATENT STAIR GAUGE

No. 674w.



This Gauge is to be used in connection with any carpenter's steel square, and can be adjusted to any pitch or angle desired. For cutting in rafters, braces, stairs, etc., it will soon pay its cost and prove one of the most valuable tools in a carpenter's kit.

The attachment is furnished either plain or graduated in inches, 4ths, 12ths, and 24ths.

It is made in the shape of a steel angle, 3/4 × 1/2 in., 1/2 in. thick, ground straight and nickel-plated.

Prices:

A.	Plain, 18 in., nickel-plated	9/-
B.	" 28 " " "	10/6
C.	Graduated, 18 in., nickel-plated	11/6
D.	" 28 " " "	16/9

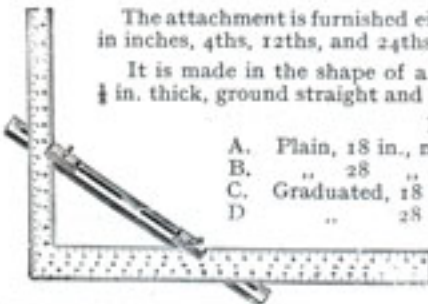

STAIR GAUGE FIXTURES

No. 675w.

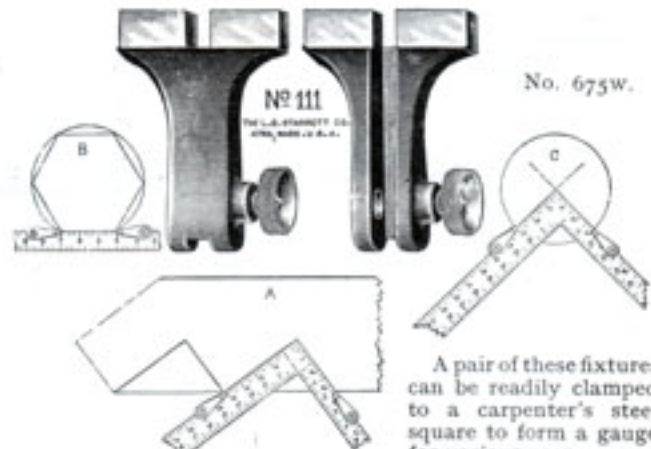

A pair of these fixtures can be readily clamped to a carpenter's steel square to form a gauge for various uses.

Sketch A shows the gauge as applied for laying out a stair stringer; Sketch B, laying off hexagon angles; Sketch C, as used as a centre gauge or in quartering a circle.

These fixtures are light, neat, efficient, and low priced.

Price 3/3 per pair.

LEVEL SIGHTS

For sighting levels from one given point to another a distance away. Can be quickly attached to any level. When not in use, will pack away in a small space. Furnished in pairs.



No. 676w. For Wood Levels. Japanned. Per pair 5/-



No. 677w. For Metal Levels. Japanned. Per pair 5/-





BLIND NAIL TOOL No. 678w.

This tool can be attached to a 1/2 in. chisel, and permits a shaving of any desired thickness to be raised, for blind nailing or for inlaid work. Nickel-plated.

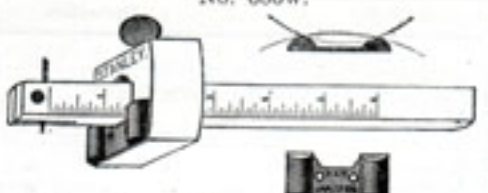
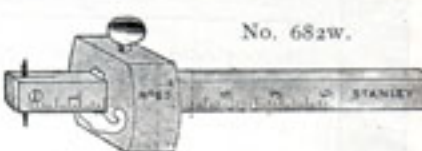

2 1/2 in. long price 1/5 each.

MARKING GAUGES

<p align="center">No. 679w.</p>  <p>Beech, Box screw ... price -/9 Polished 1/4</p>	<p align="center">No. 680w.</p>  <p>Beech, with plate for concave and convex work price 1/- No. 681w. In Boxwood 3/9</p>	<p align="center">No. 682w.</p>  <p>Boxwood. Polished. Adjustable point. Price 3/3</p>
<p align="center">No. 683w.</p>  <p>Beech. Polished. Adjustable point. Price 2/1</p>	<p align="center">No. 684w.</p>  <p>Best Beech price 1/1 .. 685w. .. plated 1/6</p>	<p align="center">No. 686w.</p>  <p>London Pattern, with Box wedges (as shown) price 2/- No. 687w. Unpolished Beech Pattern Maker's Gauge price -/9</p>

CUTTING GAUGES



No. 688w. Best Beech price 1/4
.. 689w. .. plated 2/-
.. 690w. .. head faced with Brass price 2/9
.. 691w. Rosewood, as illustrated .. 3/6
.. 692w. Ebony, oval, head plated .. 7/6

MORTISE GAUGES



Ebony. Turn screw or thumbscrew. Slide and strips in head.
No. 693w. 7/-



Ebony. Oval, head with shield. Thumb or turn screw slide. Brass strips.
No. 695w. 7/6

MORTISE GAUGES



Rosewood, with improved split stem.
No. 696w. 2/9
No. 697w. Ditto, with slide price 4/3



Rosewood, with Brass slide and shield and Brass-plated head.
No. 698w. 6/-



Rosewood, with turn screw or thumbscrew slide. Brass strips and shield in head.
No. 699w. 6/9

METAL GAUGES

Marking—Nickel-plated, Single Bar
No. 700w.



Length, 6 1/2 in. Metal head, pin point.
Price 2/6

Marking and Mortise—Nickel-plated, Double Bar
No. 701w.



Metal head, pin point price 4/9

Marking and Mortise, Double Bar
No. 702w.

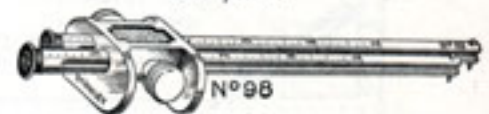

Length, 6 1/2 in. Metal head, pin point, and roller cutter.
Price 6/3

COMBINATION ROLLER GAUGES

No. 703w.



Price 5/-

Length, 8 in.

Polished and Nickelled.

No. 704w.



Price 6/3

For lining out single and double work, measuring depths, and striking circles, etc. When used as a single gauge the shorter beam slides into head. Rollers take the place of the usual spur and run over the roughest work with perfect ease and accuracy.

Builders' and Furnishing Ironmongery

PATENT RULE ATTACHMENTS

No. 705w.

Specially designed for the use of draughtsmen, clerks of works, foremen, etc., for setting out and marking off.

Fig. 1 is for use on the rule as a gauge as shown in Fig. 5, and may be used for striking curves or circles by using a bradawl for a centre, as shown in Fig. 4.

Fig. 2 is fitted with a fine steel point, which folds up into the fence when not in use, and so admits of same being used as shown in Fig. 5. This point dispenses with the use of a bradawl, and is specially designed for use on the drawing board.

Fig. 3 is adapted to hold a pencil, drawing pen, or steel point, and to be used with either Fig. 1 or 2 when using the rule as a beam compass or trammel as shown in Fig. 4.

Prices, in Solid Brass:

Polished.—Fig. 1, 2/- each. Fig. 2, 2/3 each.

Fig. 3, 2/3 each.



Fig. 1.



Fig. 2.



Fig. 3.



Fig. 4.



Fig. 5.

TRAMMEL HEADS

BRONZED

No. 706w.



To take $\frac{1}{8}$ 1 $1\frac{1}{2}$ in. bar.
Price 6/3 8/- 11/- pair.

NICKELLED

No. 707w.

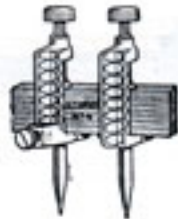

They can be attached to one side of a straight stick. The pencil socket will take an ordinary sized pencil, or a full-sized oval-shaped carpenters' pencil. For Straight Edge up to $1\frac{1}{2}$ in. Price ... 4/6 per pair.

RULE TRAMMEL POINTS

No. 708w.

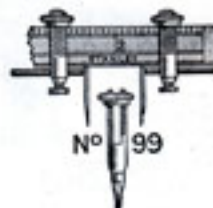

These can be attached to carpenters' rules of any ordinary width. They have movable steel points and a pencil socket. For Straight Edge up to $\frac{1}{2}$ in. Price ... 4/- per pair.

POLISHED BRASS

No. 709w.

With Steel Points and Pencil Holder.



To take a bar $\frac{1}{2} \times \frac{1}{2}$ in. Price ... 7/3 per pair.



No. 710w.

Best English made, Polished Brass, Steel Points, and Pencil Holder.

Size $\frac{3}{8} \times \frac{1}{2}$ in. 3/6 per pair.
.. $\frac{1}{2} \times \frac{3}{8}$.. 4/- ..
.. $\frac{3}{4} \times \frac{1}{4}$.. 4/9 ..
.. 1 $\times \frac{1}{2}$.. 5/6 ..

No. 711w.

These are made of bronze metal nickel-plated, with forged steel points, hardened. Either point can be removed and the pencil socket accompanying each pair put in its place. Adjustable like spring dividers. Light and durable.

No. A.
With 3 in. points, adjustable, 13/6
No. B.
With 3 in. points, not adjustable, 8/9
No. C.
Extra long points, 5 in., per pair 2/3



For Trammels used by Engineers and others, see Metal Catalogue.

HAMMERS

BEST C.S. JOINERS OR WARRINGTON PATTERN



No. 712W

No. ...	0	1	2	3	4	5	6	7	8	
Price	1/11	1/-	1/1	1/3	1/4	1/6	1/8	1/9	2/2	each.

C.S. EXETER OR LONDON PATTERN

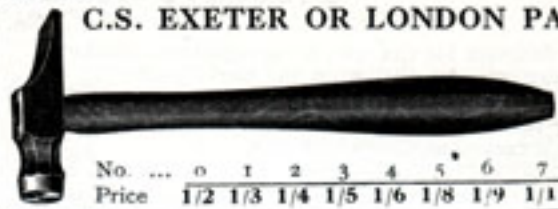

No. 713W.

No. ...	0	1	2	3	4	5	6	7	8	
Price	1/2	1/3	1/4	1/5	1/6	1/8	1/9	1/11	2/1	each.

PIN HAMMERS

CROSS PANE No. 714W.



Weight, 2 oz.	Price...	1/2 each.
" 4 "	"	"	"	"	1/3 "

BALL PANE No. 715W

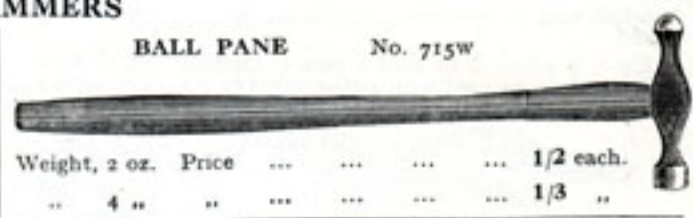

Weight, 2 oz.	Price	1/2 each.
" 4 "	"	"	"	"	1/3 "

BEST CANTERBURY HAMMER
With Polished Oval Handle.



No. 716W.

No. ...	0	1	2	3	4	5	6	
Price	2/6	3/-	3/3	3/6	3/9	4/-	4/6	each.

IMPROVED SOLID C.S. FARRIER'S HAMMER

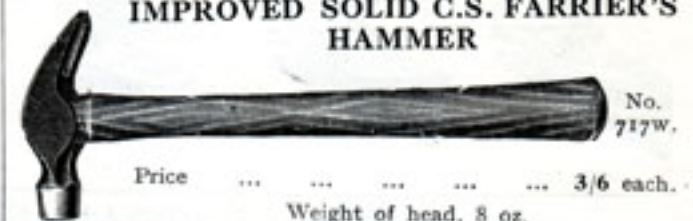

No. 717W.

Price ... 3/6 each.

Weight of head, 8 oz.

ADZE EYE CLAW No. 718W.

These are of Solid Steel and highly finished.

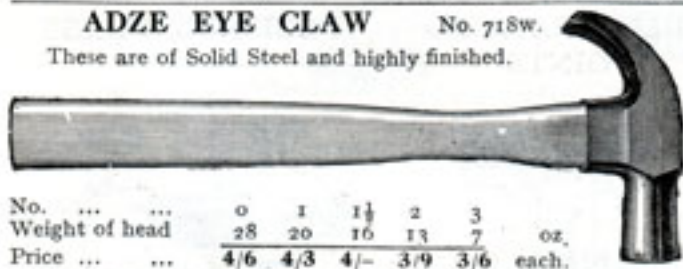

No. ...	0	1	1 1/2	2	3	
Weight of head	28	20	16	13	7	oz.
Price ...	4/6	4/3	4/-	3/9	3/6	each.

CAST STEEL SHOEMAKER'S

With Polished Handle.
No. 719W.

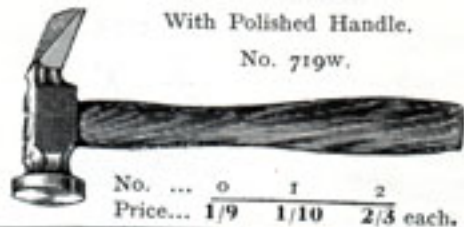

No. ...	0	1	2	
Price...	1/9	1/10	2/3	each.

GEOLOGISTS' HAMMERS

With Oval Ash Handles. No. 720W.

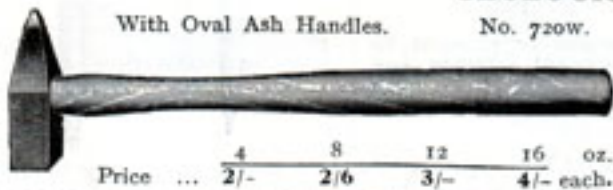

Price ...	4	8	12	16	oz.
	2/-	2/6	3/-	4/-	each.

With Oval Ash Handles. No. 721W.

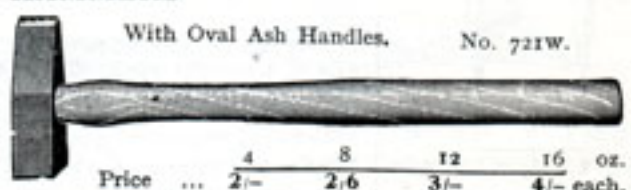

Price ...	4	8	12	16	oz.
	2/-	2/6	3/-	4/-	each.

CLAW TACK HAMMER



No. 722W.

Price ... Black. ... 1/- each.

WARRINGTON TACK HAMMER



No. 723W.

Price ... Black. ... 1/2 each.

WROUGHT COAL HAMMER

No. 724W.

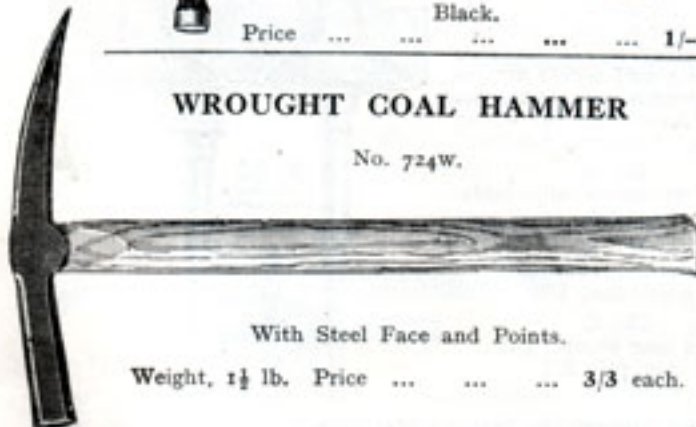

With Steel Face and Points.

Weight, 1 1/2 lb. Price ... 3/3 each.

COOPER'S SHAVE



No. 725W.

Price 3/-

HAMMER PINCERS



No. 726W.

Length, 6 in. Price 3/6 each.

TOOL AND MACHINE MERCHANTS

BEST QUALITY NAIL PULLERS The Original Make.



No. 727w.

With these Tools boxes can be opened in one-quarter the time and with one-tenth the labour required by the old method with chisel and hammer. Nails are drawn out without breaking or bending, and box and cover remain sound.

Length ...	16	19½	28 in. overall.
Price ...	10/9	13/-	25/- each.

No. 728w.



Special make, one size only. Length, 19½ in. Price 9/- Fully Warranted.

No. 729w. As above, cheaper quality. Length, 23 in. Price 6/- each.

WARRANTED CAST STEEL CASE OPENERS.

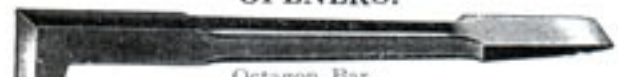

Octagon Bar.

Length ...	12	14	16 in.
No. 730w.	Price 5/6	6/-	6/9 ea.

Round Bar.

„ 731w.	Price 3/9	4/-	4/6 „
---------	-----------	-----	-------



Round Bar.

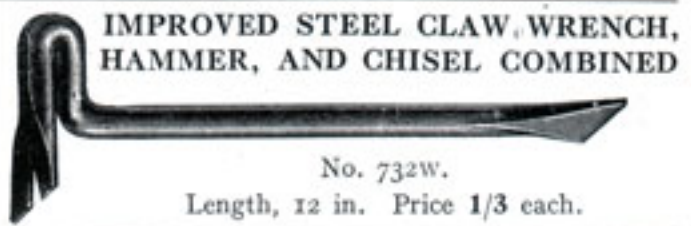

IMPROVED STEEL CLAW, WRENCH, HAMMER, AND CHISEL COMBINED

No. 732w.

Length, 12 in. Price 1/3 each.

CIGAR OR CONFECTIONER'S BOX OPENER

No. 733w.



Beech handled, riveted through. Price 1/9 each.

AMERICAN NAIL PULLER

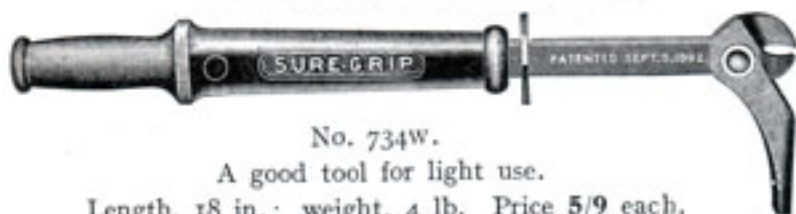

No. 734w.

A good tool for light use. Length, 18 in.; weight, 4 lb. Price 5/9 each.

ORANGE CHEST OPENERS

No. 735w.



Best Cast Steel. Price 6/- each.

THE HANDY BOX SCRAPER

No. 736w.

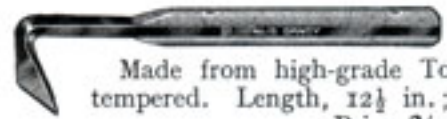

Made from high-grade Tool Steel. Hardened and tempered. Length, 12½ in.; width of blade, 2½ in. Price 3/- each.

TACK LIFTER

No. 737w.



Handled in Beech. Price -/9 each.

STRONG IRON HANDLED GROCER'S HAMMER

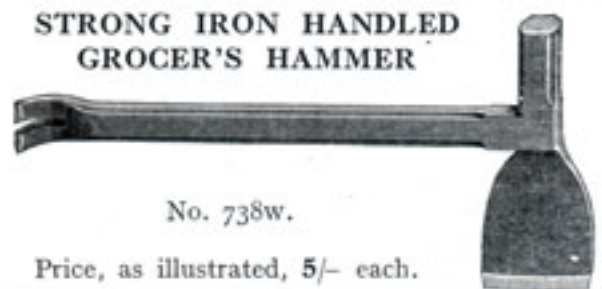

No. 738w.

Price, as illustrated, 5/- each.

THE HANDY COMBINATION TOOL

No. 739w.



For opening Cases, etc. It does the work of hammer, hatchet, case opener, and nail extractor. Best English manufacture. Price 5/- each.

CAST STEEL STRIPPING BAR For opening Cases. No. 740w.



Length, 18 x ½ in. diam. Price 2/3 each.

Bronze Medal 1884—Gold Medal 1890

RICHARD MELHUIH LIMITED, LONDON, E.C.



SHINGLING HATCHETS

With Claw.
 No. 741w ... 1 2 3
 Price ... 3/9 3/10 4/3 each.
 Bright and Japanned



SHINGLING HATCHETS

Hammer Head.
 No. 742w ... 1 2 3
 Price ... 3/6 3/9 4/- each.
 Bright and Japanned.



HANDLED KENT AXES
Best Quality

No. 743w.
 Weight 2 2½ 3 3½ 4 5 lb.
 Price 4/6 5/- 5/9 6/9 7/6 9/9 each.



WARRANTED STEEL POLL HATCHETS

No. 744w.
 No. 0 1 2 3
 Price 2/3 2/6 2/9 3/- each.

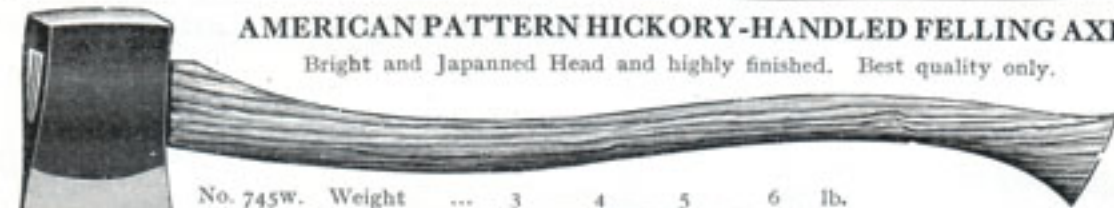

AMERICAN PATTERN HICKORY-HANDLED FELLING AXE

Bright and Japanned Head and highly finished. Best quality only.

No. 745w. Weight ... 3 4 5 6 lb.
 Price ... 6/6 7/6 8/6 9/6 each.



SOLID C.S. AMERICAN PATTERN AXE HEAD

Weight 4 5 6 lb.
 Price 5/6 6/6 7/6 each.

No. 746w.



KENT AXE HEAD

No. 747w.

1/8 lb.
 2 to 6 lb.

ENGLISH TIMBER FELLING AXE HEAD

No. 748w.

1/9 lb.
 4 to 7 lb.

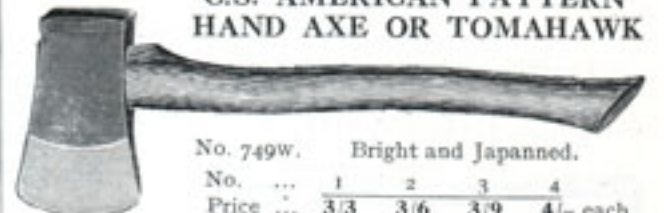
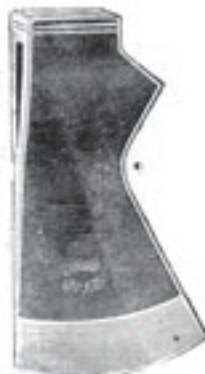

C.S. AMERICAN PATTERN HAND AXE OR TOMAHAWK

No. 749w. Bright and Japanned.

No. ... 1 2 3 4
 Price ... 3/3 3/6 3/9 4/- each.



WHEELER'S ADZE

No. 750w.

No. ... 1 2 3
 Price ... 6/6 6/9 7/- each.



CARPENTER'S ADZE

No. 751w.

No. ... 1 2 3
 Price ... 4/6 4/9 5/- each.



COOPER'S ADZE

No. 752w.

No. ... 1 2 3
 Price ... 5/3 5/6 6/- each.



WOOD HANDLED BUNG TICKLER

No. 753w.

Price ... 2/6 each.
 Ditto, all Iron ... 3/6 ..



COOPER'S DRIVER

No. 754w.

Wood Head, Iron Shod. Price 4/6 each.



COOPER'S BUNG BORER

No. 755w.

Complete with Handle.
 Size ... 2 2½ 3 in.
 Price ... 9/6 10/6 12/9 each.

TOOL AND MACHINE MERCHANTS

BEST QUALITY BROOM HOOKS

No. 756w.

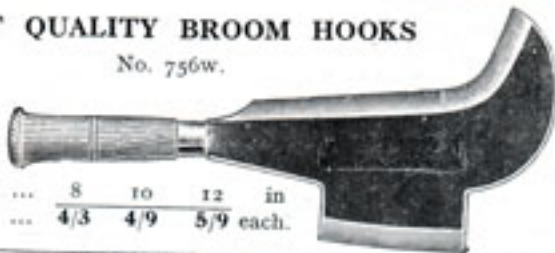

Size	...	8	10	12	in.
Price	...	4/3	4/9	5/9	each.

STAFFORDSHIRE BILL HOOKS

No. 757w



Size	...	8	10	12	in.
Price	...	3/6	4/-	5/-	each.

BENCH KNIVES

Light, for Cardboard, etc.



No. 758w.

To cut	12	15	in.
Price	25/-	30/-	

No. 759w. Strong.

To cut	16	18	20	24	30	36	in.
Price	34/6	45/-	53/6	65/-	75/-	86/6	

RUBBER TAPPING KNIVES

No. 760w



Price -/10 each; 8/9 per doz.

TIMBER SCRIBERS

Rosewood Handles.



No. 761w.

Size	1/2	1	1 1/2	in.
Price	3/9	4/-	6/-	each.



FARRIERS' KNIVES

No. 762w.

Price	1/6	each.
-------	-----	-----	-----	-----	-----	-----	-------

FARRIERS' SEARCHERS

No. 763w.

Price	1/5	each.
-------	-----	-----	-----	-----	-----	-----	-------

MOULDERS' TOOLS



SPOON TOOL No. 764w.
Size, 1 1/2 x 1/2 in., price 2/9 each.



TAPER TROWELS

No. 765w.

Size	...	1 1/2 x 6	1 1/2 x 6 1/2	1 1/2 x 7 in.
Price	...	2/2	2/6	2/9 per doz.



ROUND EDGE FLANGE CORNER SMOOTHER

No. 766w.
Size, 3 x 2 in.
Price 3/3 each.



MOULDERS' SQUARE TROWELS

No. 767w.

Size	...	6 x 1 1/2	6 x 1 1/2	6 x 1 1/2	6 x 1 1/2	in.
Price	...	2/-	2/2	2/6	2/9	each.

HEART AND SQUARE TROWELS

No. 768w.

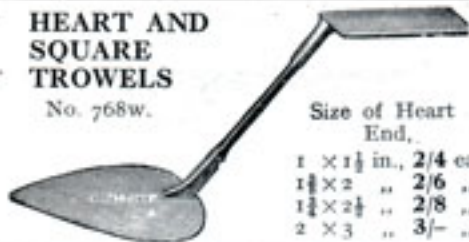

Size of Heart End,	
1 x 1 1/2 in.	2/4 ea
1 1/2 x 2	2/6 "
1 1/2 x 2 1/2	2/8 "
2 x 3	3/- "

For fuller information, see our Illustrated Metal Workers' Catalogue.

SCOTCH CLEANERS

No. 769w.

Size	1/2	3/4	1	1 1/4	1 1/2	1 3/4	2	in.
Price	2/2	2/4	2/9	2/10	3/6	3/8	4/3	each.

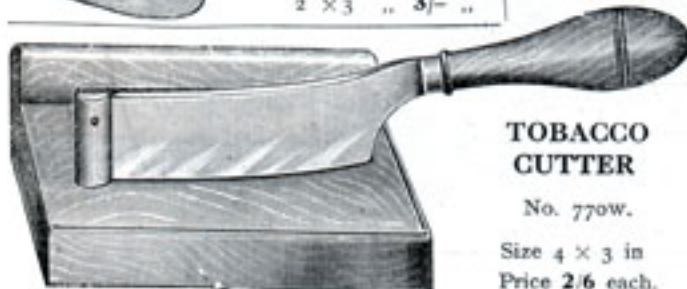

TOBACCO CUTTER

No. 770w.

Size 4 x 3 in
Price 2/6 each.

SLIDING CALLIPER

No. 771w.

In Brass. Length, 4 in.
Marked English and Metric.

Price ... 2/6 each.

PIG SCRAPER WITH HOOK



No. 772w.

Price 3/9 each.

Builders' and Furnishing Ironmongery

RICHARD MELHUISE LIMITED, LONDON, E.C.

BEECH PLANE HANDLES



No. 773W.
Open Jack
Plane Handle.
-9 each.



No. 774W.
Closed Try
Plane
Handle.
1/3 each.



BEECH SAW HANDLES

No. 775W.

Hand Saw	...	1/6 each.
Back "	...	1/6 "
For Disston's Saws:		
No. D8	...	3/- each.
" 7	...	2/2 "
" 16	...	3/2 "
" 12	...	4/- "

ONE-MAN CROSS-CUT HANDLE



No. 776W.
Price ... 1/3 each.
For Disston's Saws.

BOX AND TILLER FOR PIT SAWS



No. 777W.

Price 5/6 per pair.

CROSS-CUT HANDLES



No. 778W.
Climax Pattern.
Price ... 1/9 per pair.

ASH HANDLES

No. 779W.
For Cross-cut Saws.



Price ... 1/4 per pair.

HATCHET (ASH) HANDLES

No. 780W.



Length ...	16	18	20	22	in.
Price ...	-/6	-/7	-/9	-/10	each.

ENGINEERS' HAMMER HANDLES

No. 781W.



Selected Hickory.

Length ...	12	14	16	18	in.
Price ...	-/4	-/5	-/5½	-/6	each.

HANDLES FOR AMERICAN PATTERN CLAW HAMMERS

No. 782W.



Length, 14 in. Price ... -/5 each.

CARPENTERS' HAMMER HANDLES

No. 783W.



Selected Ash.

Length ...	10	12	14	16	in.
Price ...	-/3	-/3	-/3½	-/4	each.

No. 784W. SELECTED HICKORY ADZE HANDLES. Length, 32 in. Price 1/10 each.

HICKORY FELLING AXE HANDLE

No. 785W.

Length, 36 in.
Best, 1/10; Second, 1/8 each.



HICKORY PICK HANDLES



No. 786W.
Length, 36 in.
Best, 1/8; Second, 1/4 each.

HICKORY SLEDGE HAMMER HANDLES



No. 787W.

Length	30	36	in.
Price	-/10	1/-	each.

SCREW BOXES AND TAPS

No. 788W.

Best English Make.

Size ...	½	¾	1	1½	2	2½	3
Price ...	10/-	10/-	10/6	12/-	14/-	15/-	16/- 19/-

Size ...	½	¾	1	1½	2	2½	3
Tap only	2/-	2/-	2/-	2/3	2/3	3/-	3/3 3/9

21/- 26/6 33/- complete.
1½ 1½ 2 in.
4/6 5/6 6/6 each.



FRENCH PATTERN BOXES AND TAPS

No. 789W.

These cut a much cleaner thread than the ordinary pattern.



Size	½	¾	1	1½	2	2½	3	in.
Price	10/-	10/6	11/6	12/6	13/6	14/-	14/6	20/- each.

NOTE. These prices are subject to Rate of Exchange Fluctuations.

Horticultural and Estate Appliances

TOOL AND MACHINE MERCHANTS

WOOD HANDLES, ETC.

**BEST ROUND ASH,
BRASS FERRULES**
No. 790w.



Price -/3 each, 2/9 per doz.

**CARVER'S PATTERN, POL-
ISHED BEECH, Etc.** No. 791w.



Beech ... price -/3 each, 2/6 doz.
Boxwood .. -/4 .. 3/6 ..

OCTAGON BOXWOOD
No. 792w.



Price -/6 each, 5/6 per doz.

**ROUND ASH, TWO
MALLEABLE FERRULES**
No. 793w.



Price -/6 each, 5/- per doz.

**SOCKET CHISEL HANDLES,
IRON HOOPED, POLISHED**
No. 794w.



Price -/6 each, 5/6 per doz.

MORTISE CHISEL HANDLES
No. 795w.



Price -/8 each, 7/6 per doz.

**SCREWDRIVER HANDLES,
LONDON PATTERN**
No. 796w.



Ferrules	1/2	3/4	1	1 1/4	1 1/2	1 3/4	2	2 1/4	2 1/2	2 3/4	3	3 1/4	3 1/2	3 3/4	4	4 1/4	4 1/2	4 3/4	5	5 1/4	5 1/2	5 3/4	6	6 1/4	6 1/2	6 3/4	7	7 1/4	7 1/2	7 3/4	8	8 1/4	8 1/2	8 3/4	9	9 1/4	9 1/2	9 3/4	10	10 1/4	10 1/2	10 3/4	11	11 1/4	11 1/2	11 3/4	12	12 1/4	12 1/2	12 3/4	13	13 1/4	13 1/2	13 3/4	14	14 1/4	14 1/2	14 3/4	15	15 1/4	15 1/2	15 3/4	16	16 1/4	16 1/2	16 3/4	17	17 1/4	17 1/2	17 3/4	18	18 1/4	18 1/2	18 3/4	19	19 1/4	19 1/2	19 3/4	20	20 1/4	20 1/2	20 3/4	21	21 1/4	21 1/2	21 3/4	22	22 1/4	22 1/2	22 3/4	23	23 1/4	23 1/2	23 3/4	24	24 1/4	24 1/2	24 3/4	25	25 1/4	25 1/2	25 3/4	26	26 1/4	26 1/2	26 3/4	27	27 1/4	27 1/2	27 3/4	28	28 1/4	28 1/2	28 3/4	29	29 1/4	29 1/2	29 3/4	30	30 1/4	30 1/2	30 3/4	31	31 1/4	31 1/2	31 3/4	32	32 1/4	32 1/2	32 3/4	33	33 1/4	33 1/2	33 3/4	34	34 1/4	34 1/2	34 3/4	35	35 1/4	35 1/2	35 3/4	36	36 1/4	36 1/2	36 3/4	37	37 1/4	37 1/2	37 3/4	38	38 1/4	38 1/2	38 3/4	39	39 1/4	39 1/2	39 3/4	40	40 1/4	40 1/2	40 3/4	41	41 1/4	41 1/2	41 3/4	42	42 1/4	42 1/2	42 3/4	43	43 1/4	43 1/2	43 3/4	44	44 1/4	44 1/2	44 3/4	45	45 1/4	45 1/2	45 3/4	46	46 1/4	46 1/2	46 3/4	47	47 1/4	47 1/2	47 3/4	48	48 1/4	48 1/2	48 3/4	49	49 1/4	49 1/2	49 3/4	50	50 1/4	50 1/2	50 3/4	51	51 1/4	51 1/2	51 3/4	52	52 1/4	52 1/2	52 3/4	53	53 1/4	53 1/2	53 3/4	54	54 1/4	54 1/2	54 3/4	55	55 1/4	55 1/2	55 3/4	56	56 1/4	56 1/2	56 3/4	57	57 1/4	57 1/2	57 3/4	58	58 1/4	58 1/2	58 3/4	59	59 1/4	59 1/2	59 3/4	60	60 1/4	60 1/2	60 3/4	61	61 1/4	61 1/2	61 3/4	62	62 1/4	62 1/2	62 3/4	63	63 1/4	63 1/2	63 3/4	64	64 1/4	64 1/2	64 3/4	65	65 1/4	65 1/2	65 3/4	66	66 1/4	66 1/2	66 3/4	67	67 1/4	67 1/2	67 3/4	68	68 1/4	68 1/2	68 3/4	69	69 1/4	69 1/2	69 3/4	70	70 1/4	70 1/2	70 3/4	71	71 1/4	71 1/2	71 3/4	72	72 1/4	72 1/2	72 3/4	73	73 1/4	73 1/2	73 3/4	74	74 1/4	74 1/2	74 3/4	75	75 1/4	75 1/2	75 3/4	76	76 1/4	76 1/2	76 3/4	77	77 1/4	77 1/2	77 3/4	78	78 1/4	78 1/2	78 3/4	79	79 1/4	79 1/2	79 3/4	80	80 1/4	80 1/2	80 3/4	81	81 1/4	81 1/2	81 3/4	82	82 1/4	82 1/2	82 3/4	83	83 1/4	83 1/2	83 3/4	84	84 1/4	84 1/2	84 3/4	85	85 1/4	85 1/2	85 3/4	86	86 1/4	86 1/2	86 3/4	87	87 1/4	87 1/2	87 3/4	88	88 1/4	88 1/2	88 3/4	89	89 1/4	89 1/2	89 3/4	90	90 1/4	90 1/2	90 3/4	91	91 1/4	91 1/2	91 3/4	92	92 1/4	92 1/2	92 3/4	93	93 1/4	93 1/2	93 3/4	94	94 1/4	94 1/2	94 3/4	95	95 1/4	95 1/2	95 3/4	96	96 1/4	96 1/2	96 3/4	97	97 1/4	97 1/2	97 3/4	98	98 1/4	98 1/2	98 3/4	99	99 1/4	99 1/2	99 3/4	100	100 1/4	100 1/2	100 3/4
----------	-----	-----	---	-------	-------	-------	---	-------	-------	-------	---	-------	-------	-------	---	-------	-------	-------	---	-------	-------	-------	---	-------	-------	-------	---	-------	-------	-------	---	-------	-------	-------	---	-------	-------	-------	----	--------	--------	--------	----	--------	--------	--------	----	--------	--------	--------	----	--------	--------	--------	----	--------	--------	--------	----	--------	--------	--------	----	--------	--------	--------	----	--------	--------	--------	----	--------	--------	--------	----	--------	--------	--------	----	--------	--------	--------	----	--------	--------	--------	----	--------	--------	--------	----	--------	--------	--------	----	--------	--------	--------	----	--------	--------	--------	----	--------	--------	--------	----	--------	--------	--------	----	--------	--------	--------	----	--------	--------	--------	----	--------	--------	--------	----	--------	--------	--------	----	--------	--------	--------	----	--------	--------	--------	----	--------	--------	--------	----	--------	--------	--------	----	--------	--------	--------	----	--------	--------	--------	----	--------	--------	--------	----	--------	--------	--------	----	--------	--------	--------	----	--------	--------	--------	----	--------	--------	--------	----	--------	--------	--------	----	--------	--------	--------	----	--------	--------	--------	----	--------	--------	--------	----	--------	--------	--------	----	--------	--------	--------	----	--------	--------	--------	----	--------	--------	--------	----	--------	--------	--------	----	--------	--------	--------	----	--------	--------	--------	----	--------	--------	--------	----	--------	--------	--------	----	--------	--------	--------	----	--------	--------	--------	----	--------	--------	--------	----	--------	--------	--------	----	--------	--------	--------	----	--------	--------	--------	----	--------	--------	--------	----	--------	--------	--------	----	--------	--------	--------	----	--------	--------	--------	----	--------	--------	--------	----	--------	--------	--------	----	--------	--------	--------	----	--------	--------	--------	----	--------	--------	--------	----	--------	--------	--------	----	--------	--------	--------	----	--------	--------	--------	----	--------	--------	--------	----	--------	--------	--------	----	--------	--------	--------	----	--------	--------	--------	----	--------	--------	--------	----	--------	--------	--------	----	--------	--------	--------	----	--------	--------	--------	----	--------	--------	--------	----	--------	--------	--------	----	--------	--------	--------	----	--------	--------	--------	----	--------	--------	--------	----	--------	--------	--------	----	--------	--------	--------	----	--------	--------	--------	----	--------	--------	--------	----	--------	--------	--------	----	--------	--------	--------	----	--------	--------	--------	----	--------	--------	--------	----	--------	--------	--------	----	--------	--------	--------	----	--------	--------	--------	----	--------	--------	--------	----	--------	--------	--------	-----	---------	---------	---------

**SCREWDRIVER HANDLES, BOX-
WOOD, REGISTERED PATTERN**
No. 797w.



For 3 4 5 6 in. Screwdrivers.
Price -/6 -/6 -/9 1/- each.
For ... 7 8 9 in. Screwdrivers.
Price ... 1/- 1/3 1/6 each.

BRADAWL HANDLES



No. 798w.
Beech 1/8, Box 2/9 per doz.

FILE HANDLES



No. 799w.
Iron Ferrules, 1/3 per doz.,
14/- per gross.

**"EVERLASTING" PULP
COMPOSITION HANDLES** No. 800w.

Will not split, however tightly the File may be driven in. Cleanly in use and proof against shrinkage.

Length ... 4 4 1/2 5 in.
Price ... 2/3 2/10 3/- per doz.



UNIVERSAL FILE HANDLE No. 801w.

In Japanned Iron with Clamp to adjust it to various sizes of File Tangs. Price 1/- each.

FILE HANDLES Smallest sizes about 3/8 in. diameter. Largest sizes about 1 in. diameter.

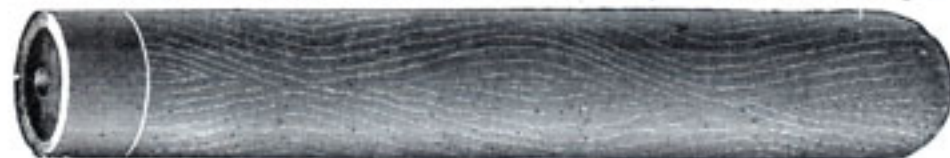

LOCK-JAW FILE HANDLE

No. 802w.



Will neither split nor rust.
Price -/3 1/2 each, 3/- per doz.

No. 803w.

Yew Wood, small 1/2 per doz.
" medium 1/4 "
" large 1/6 "

Electric and Wireless Engineers

RICHARD MELHUISE LIMITED, LONDON, E.C.



No. 804w.

KAYE'S SEAMLESS STEEL CANS

With fast spouts. Very strong.

To hold ...	$\frac{1}{4}$	$\frac{1}{2}$	$\frac{3}{4}$	1	1 $\frac{1}{2}$	2	pt.
Price ...	2/3	2/10	3/4	4/-	4/8	5/8	each.

With interchangeable Steel spouts and patent slide feed hole. Riveted Steel handles.

To hold :

	$\frac{1}{4}$	$\frac{1}{2}$	$\frac{3}{4}$	1	1 $\frac{1}{2}$	2	pt.
Price	3/-	3/4	3/10	4/6	5/2	6/6	each.



No. 805w.

MELHUISE'S STEEL OILERS. Best quality. Seamless.

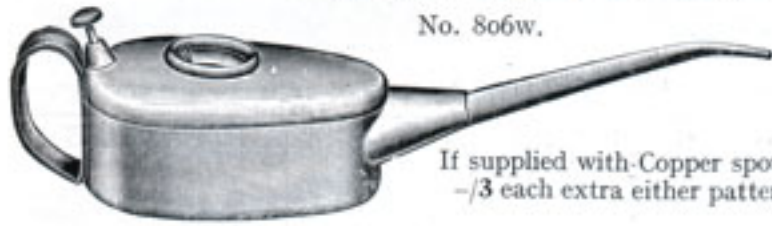

No. 806w.

If supplied with-Copper spouts, -/3 each extra either pattern.



No. 807w.

To hold ...	$\frac{1}{4}$	$\frac{1}{2}$	$\frac{3}{4}$	1	1 $\frac{1}{2}$	2	pt.
Price ...	1/6	1/10	2/3	2/8	3/6	3/9	each.

To hold ...	$\frac{1}{4}$	$\frac{1}{2}$	$\frac{3}{4}$	1	1 $\frac{1}{2}$	2	pt.
Price ...	1/10	2/2	2/6	2/10	3/9	4/-	each.



No. 808w.

REAPER CAN
To hold $\frac{1}{4}$ pt.
Price 7/6 per doz.
Less not supplied.



ALL BRASS BENCH CAN

Polished.
Price 1/6 each.

No. 809w.



No. 810w.

IMPROVED WIDE-MOUTH CAN

Strong Brass bottom.
Diameter, 2 $\frac{1}{2}$ in.
Price ... -/11 each.

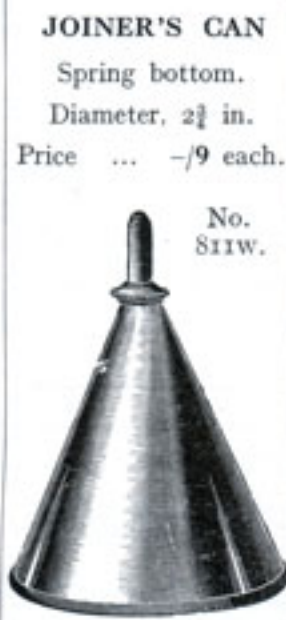

JOINER'S CAN

Spring bottom.
Diameter, 2 $\frac{1}{2}$ in.
Price ... -/9 each.

No. 811w.



No. 812w.

AGRI-CULTURAL OILER

Very strong.
Brass bottom.
 $\frac{1}{4}$ $\frac{3}{4}$ pt.
1/3 1/6 each.

MACHINERY OIL CANS

With fast Steel spouts. Extra strong.

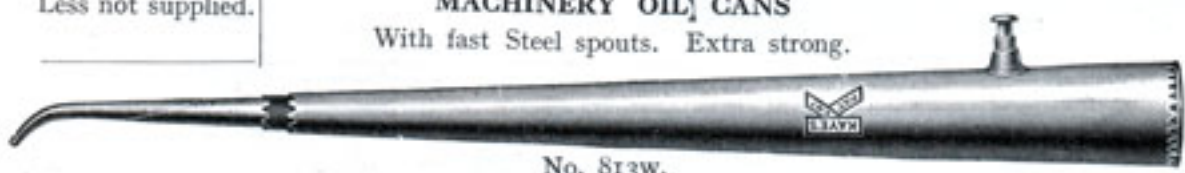

No. 813w.

Length	12	18	24	30	36	42	in.
Price	4/-	4/6	5/-	5/6	6/2	6/10	each.

Bronze Medal 1884—Gold Medal 1890

TOOL AND MACHINE MERCHANTS

SAW AND OTHER FILES

TAPER SAW, Single Cut.
No. 814w.



BLUNT SAW, Double Cut, Lancashire make.
No. 815w.



HALF-ROUND GULLETING
No. 816w.



ROUND GULLETING
No. 817w.



MILL SAW No. 818w.
With two round edges. Second Cut.



DOUBLE-ENDED SAW FILES



No. 819w.

REAPER FILE
No. 820w.
Double Cut. Length, 8 in.



Lengths	2½	3	3½	4	4½	5	6	7	8	9	10 in.
No. 814w	each.	-/4½	-/4½	-/4½	-/5	-/5	-/5½	-/7	-/8½	-/11	1/2	1/4
	per doz.	4/2	4/2	4/2	4/4	4/6	4/10	6/6	8/1	10/3	13/-	15/-
.. 815w	each.	—	—	-/6	-/7	-/8	-/9	-/11	1/2	1/8	—	—
	per doz.	—	—	5/6	6/6	7/6	8/6	10/6	13/-	19/-	—	—
.. 816w	each.	—	—	—	-/5½	-/6	-/6½	-/8	-/10	1/1	1/6	—
.. 817w	"	—	—	—	-/5½	-/6	-/6½	-/8	-/10	1/1	—	—
.. 818w	"	—	—	—	—	—	—	—	—	-/11	1/-	1/1
.. 819w	per doz.	—	—	—	—	—	—	—	-/7	-/8	-/9	-/10
.. 820w	"	—	—	—	—	—	—	—	6/6	7/6	8/6	9/6

HALF-ROUND CABINET RASP
No. 821w.



HALF-ROUND WOOD RASP
No. 822w.

HALF-ROUND CABINET
FILE
No. 823w.



Sizes	4	5	6	8	10	12	14 in.
No. 821w	...	-/8	-/10	1/-	1/3	1/6	1/10	2/9 each.
.. 822w	...	-/7	-/8	-/9	-/10	1/3	1/7	2/3 ..
.. 823w	...	-/8	-/10	1/-	1/3	1/6	1/10	2/9 ..



IMPROVED SHOE RASP Half-file.
No. 824w.

Length ... 8 10 in.
Price ... 1/6 2/- each.

HORSE-MOUTH RASP
No. 825w.

Price ... 4/6 each.



We carry a large stock of Engineers' Files, from 3 to 16 in., in all shapes. We wish it to be particularly noted that the quality is the finest obtainable.

The Steel used is best Crucible Cast. See our Metal Workers' List for prices.

Engineers' Tools and Machinery

T SECTION STEEL BAR CRAMPS

These T Bar Cramps are now all manufactured with the bar cold drawn to the exact section, which ensures free and at the same time perfectly fitting sliding jaws, and any jaw required to replace would also be of a perfect fit; further, the finish of the Cramps is consequently very superior.



Full Size Section.



Full Size Section.

No. 826w.



Length ...	3	3½	4	4½	5	6	7	ft.
No. A ...	12/-	12/6	12/9	13/6	13/9	—	—	each.
.. B ...	16/6	17/6	18/-	18/6	19/-	20/-	21/9	..
.. A.—Lengthening Bars ...	6/6	7/-	7/6	—	—	—	—	..
.. B.— ..	8/6	9/-	9/9	—	10/9	12/-	—	..

IMPROVED JOINER'S CRAMP

No. 827w.

Cold drawn Steel bar, screw, and handle, with Malleable Iron head and jaws.

Size of Bar, 2 × ¼ in.

Length of Bar ...	3	4	5	6	7	ft.
Price ...	21/-	22/6	24/-	25/6	27/-	ea.
Lengthening Bar ...	9/3	10/6	12/-	13/6	—	..

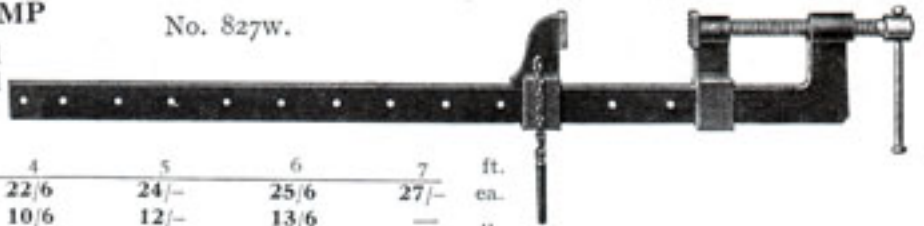

IMPROVED PATENT CRAMPS

ADVANTAGES: Self-fastening sliding jaw, which only requires pushing up to the work. The greater the pressure applied, the firmer the grip. Instant adjustment on any part of the bar.

STEEL BARS
T Section.
2½ × ¼ × ⅜ in.



DEPTH OF JAWS
2½ in.

IMPROVED HEAD

Length of Bar ...	3	4	5	6	7	ft.
To take in about ...	2 ft. 4 in.	3 ft. 4 in.	4 ft. 4 in.	5 ft. 4 in.	6 ft. 4 in.	..
Price ...	27/-	28/6	30/-	33/-	34/-	each.
Lengthening Bars ...	12/6	13/-	13/6	—	—	..

SASH CRAMPS

No. 829w.

Bright Steel Bar, 1½ × ¼ in. Black fittings. Depth of jaws, 2 in.

Length of bar ...	24	30	36	42	48	in.
To take in ...	18	24	30	36	42	..
Price ...	8/6	9/-	9/3	9/6	10/-	each



No. 830w.

PATENT CRAMP

Bright. Size 1½ × ¼ in.; depth of jaws, 1½ in.

Length of Bar ...	24	30	36	42	48	in.
To take in about ...	18	24	30	36	42	..
Price... ..	12/-	12/6	13/-	13/6	14/-	each

Goods on this page Free on Rail London only.

Builders' and Furnishing Ironmongery

TOOL AND MACHINE MERCHANTS

MACHINE-CUT SQUARE THREAD CRAMPS

Bright Screw and Handle.



No. 831w.

To take $\frac{3}{4}$ $\frac{4}{6}$ $\frac{5}{3/6}$ $\frac{6}{4/-}$ $\frac{7}{4/8}$ $\frac{8}{5/3}$ in.
Price ...

STRONG RIBBED

Bright Screw and Handle.



No. 832w.

To take ... $\frac{5}{5/-}$ $\frac{6}{5/6}$ $\frac{7}{6/6}$ $\frac{8}{8/-}$ $\frac{10}{9/-}$ $\frac{12}{9/6}$ in.
Price ...

ALL WROUGHT IRON

Bright Steel Screw and Handle.



No. 833w.

To take : $\frac{4}{6/9}$ $\frac{5}{7/6}$ $\frac{6}{8/6}$ $\frac{8}{10/-}$ $\frac{10}{11/9}$ $\frac{12}{13/-}$ in.
Price ... ea.

PIANO MAKER'S CRAMP

Best Wrought Iron.



No. 834w.

To take : $\frac{6}{25/6}$ $\frac{8}{26/3}$ $\frac{10}{28/-}$ $\frac{12}{30/-}$ $\frac{16}{37/6}$ $\frac{18}{39/6}$ in.
Price ... ea.

COACHMAKER'S CRAMP

Extra Strong. All Wrought.



No. 835w.

To take : $\frac{8}{21/-}$ $\frac{10}{22/-}$ $\frac{12}{26/-}$ $\frac{14}{30/-}$ $\frac{16}{35/-}$ $\frac{18}{39/-}$ in.
Price ... ea.

INSTANTANEOUS ACTION

Malleable Iron with Bright Steel Screw.

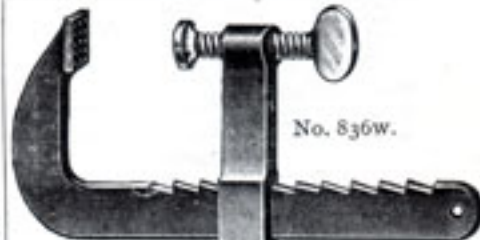

No. 836w.

To take $\frac{4}{2/6}$ $\frac{6}{3/9}$ $\frac{8}{4/6}$ $\frac{10}{5/-}$ in.
Price ... each.

STRONG MALLEABLE "G" CRAMP

With ball end screw and socket swivel head to conform to irregularity in work to be cramped.



No. 837w.

Screw is of steel with heavy square thread.

Size ... $\frac{3}{2/-}$ $\frac{4}{2/9}$ $\frac{5}{3/3}$ $\frac{6}{3/10}$ in.
Price ... each.

WOOD CRAMP

No. 838w.



Size 6 in. Price 3/6 ea.

HAMMER'S ADJUSTABLE CRAMPS



No. 839w.

By giving the bolt one-quarter turn to the left, it can be moved its full length out or in; when turning it to the right, it operates like another screw.

Size ... $\frac{3}{3/-}$ $\frac{4}{4/-}$ $\frac{5}{5/-}$ $\frac{6}{6/3}$ $\frac{8}{8/6}$ in.
Price ... each.

UNIVERSAL WOODWORKERS' CRAMPS

Cramp No. 840w is operated by one screw working both arms.

No. 841w has two independent spindles—one moving in the other. This arrangement allows a much larger variety of work.

By turning the nut on the outer spindle the two side cramps are pressed against the material, whereas the inner spindle can be fixed for a lower and higher position just depending on the dimensions of material in work.

The outer spindle is movable, and allows, therefore, a quick adjustment.

Price ... No. 840w, 5/6; No. 841w, 6/6 each.



Horticultural and Estate Appliances

FLOORING CRAMPS

BISSELL'S PATTERN

No. 842w.



Cast iron body, malleable fittings, and steel screws.

Weight, 24 lb.

For joists ... $1\frac{1}{2}$ - $3\frac{1}{2}$ $1\frac{1}{2}$ - $4\frac{1}{2}$ $1\frac{1}{2}$ - 6 in.
Price ... 18/- 19/- 20/- each.

TOP ACTION

No. 843w.

Malleable frame and steel working parts.

For joists ... $1\frac{1}{2}$ - $3\frac{1}{2}$ $1\frac{1}{2}$ - $4\frac{1}{2}$ in.
Price ... 25/- 27/6 each.

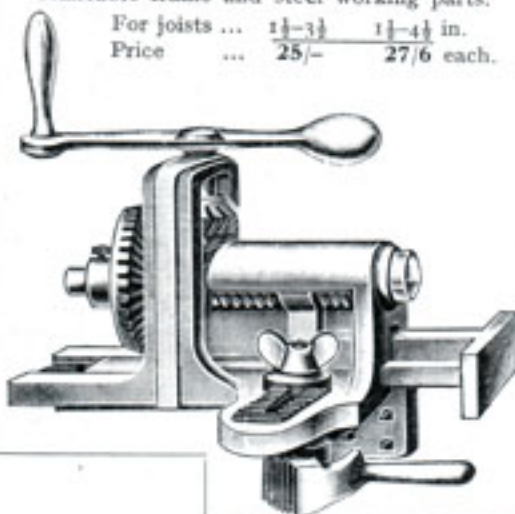

THE "RAPID"

No. 844w.

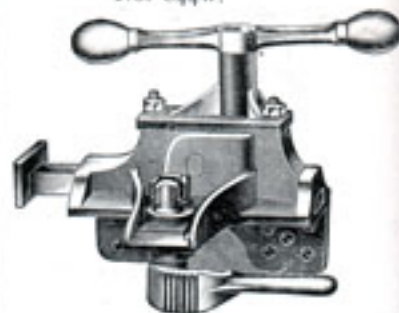

Malleable frame and steel working parts.

This is a strong and very serviceable Cramp.

Weight, 20½ lb.

To take joists $1\frac{1}{2}$ -4 in.

Price ... 28/6 each.

SINGLE PRONG

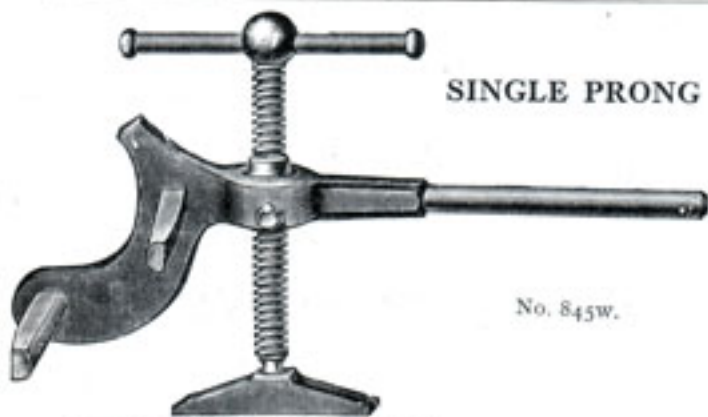

No. 845w.

Best Wrought Iron, with steel screw.

To suit joists $1\frac{1}{2}$ - $3\frac{1}{2}$ in.

Price per pair, left and right ... 27/6

DOUBLE PRONG

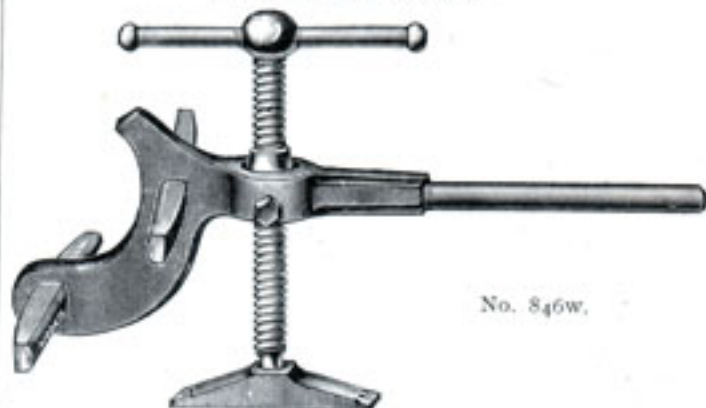

No. 846w.

Made of the same materials as Single Cramp opposite. This double-prong pattern can be used as either a left- or right-hand Cramp. For joists 2-4 in.

Price ... 15/- each.

LEVER FLOOR CRAMP

No. 847w.

Fits any sized joist without packing.

Applied and detached instantly.

Simple and cannot get out of order.

Strong and durable.

Length,
45 in.
Weight, about
20 lb.
Price
36/6 each.



CRAMP HEADS

No. 848w.

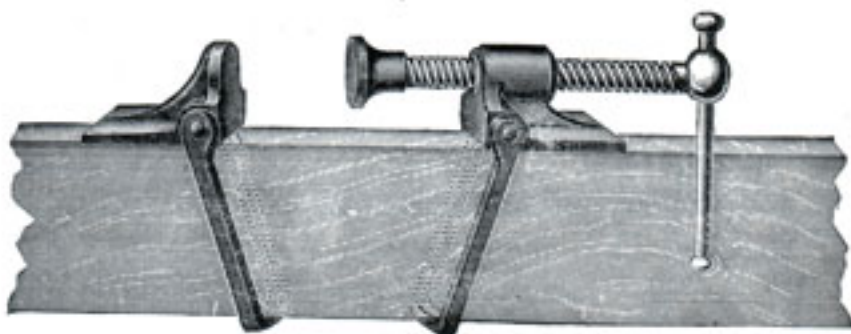

Mild steel screw and handle, wrought iron straps, other fittings cast iron

Size ...	No. 1.	No. 2.	No. 3.
Diameter of screw ...	$\frac{1}{2}$ in.	$\frac{3}{4}$ in.	$\frac{7}{8}$ in.
To suit plank ...	$4 \times 1\frac{1}{2}$ in.	$5\frac{1}{2} \times 2\frac{1}{2}$ in.	$6 \times 3\frac{1}{2}$ in.
Price per pair ...	7/6	10/6	14/-

ENGLISH AND AMERICAN BENCH STOPS

THE "GEM" BENCH STOP



No. 849w.
Nicely made and easily raised or lowered by thumb and finger.
Size $2\frac{1}{8} \times 1\frac{1}{2}$ in.
Price 1/9 each.



"CAM" STOP

No. 850w.
Painted Blue and complete with screw and metal bush.
Price ... 3/- each.
This raises wood stop from underneath bench.

SOLID IRON STOP WITH SPRING
No. 851w.

This is used in benches of our own manufacture.
Price ... 2/6 each.

JOINERS' BENCH KNIFE PATTERN

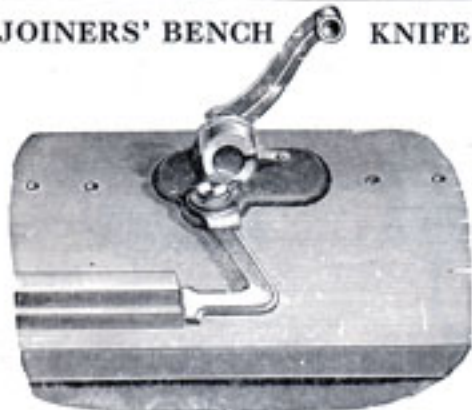

No. 852w.
It will securely hold, and can be instantly adapted to any piece of work of whatever size.
Price 5/- each.

SPRING BENCH STOP

No. 853w.
The Stop is raised or lowered by turning the slit head screw, and remains in any position required by the action of the spring.
This is one of the simplest made, and no parts are likely to get out of order.
Price ... 2/6 each.



MORRILL'S NO 1 BENCH STOP.



MORRILL'S OWN MAKE

As illustrated.
No. 854w ... 5/9 each.

MORRILL'S PATTERN

No. 855w.
English manufacture. Malleable body, mild steel screw, and steel top.
Price ... 3/3 each.

"AJAX" BENCH STOP

No. 856w.
Operated from top of bench, and made with toothed Iron or Wood Stop.
It may be instantly released and clamped in any desired position by turning the wing knob shown.
Specify whether Iron or Wood Stop is required.



Price ... 5/- each.

BENCH HOLDFAST



No. 857w.

Size :
 $10 \times \frac{3}{4}$ in.
Price 7/6

$12 \times \frac{7}{8}$ in.
Price 8/3

14×1 in.
Price 9/6

Wrought Iron, with mild steel screw and malleable arm and shoe.

DOUBLE SCREW BENCH CHOPS

No. 858w.
Size of jaws, $12 \times 3\frac{1}{4}$ in.
Price ... 3/6 each.

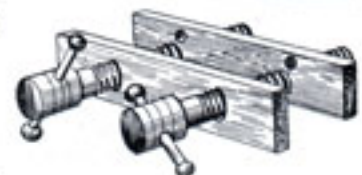

CARPENTERS' BENCH CHOPS. No. 859w.

Block ...	$20 \times 6 \times 1\frac{1}{2}$	$22 \times 6\frac{1}{2} \times 1\frac{1}{4}$	$24 \times 7 \times 2$ in.
Screw ...	2	2 $\frac{1}{2}$	2 $\frac{1}{2}$ in.
Price ...	11/6	13/6	15/6 each.

(Carriage extra.)



MALLEABLE BENCH STOP

No. 860w.
With mild steel screw and steel spring.
Size $3 \times 1\frac{1}{2}$ in.
Price .. 2/3 each.

Bronze Medal 1884—Gold Medal 1890

PATENT IMPROVED CRAMPING MACHINE



In Japanned Malleable Iron. By turning the centre cranked handle the four arms are drawn in and the four mitres are instantly closed and are nailed without a chip, rubbers being supplied with grips for protection.

To cramp from 3 x 2 to 36 x 48 in.
Height of Stand, 30 in.

No. 861w	72/6 each.
No. 862w.	As above,	without Stand	60/- ..

UNIVERSAL FRAMING CRAMP

No. 863w.
Patent.

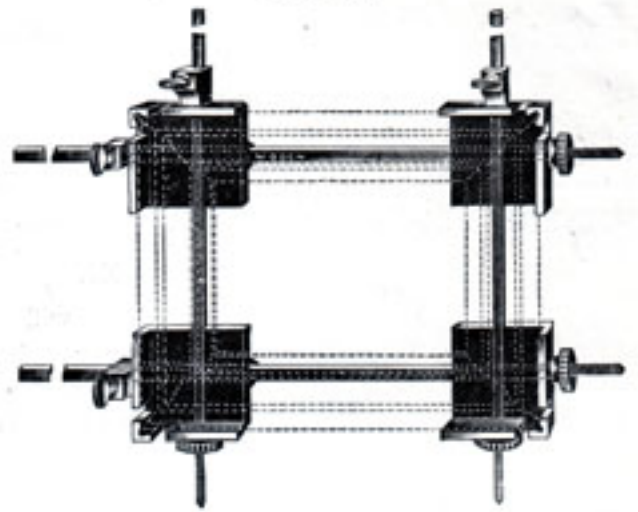

Best Cast Iron Corner Plates, accurately fitted with Cold Drawn Steel Rods.

This Cramp is specially suitable for round, oval, or square work. It is most effective, and easily and quickly manipulated. The Bars can be supplied any length that may be required for increasing the cramping capacity.

To cramp up to 3 ft. 3 in. square	...	18/6 per set.
.. larger sizes...	... extra	1/2 .. ft.

PATENT FRAMING OR CORNER CRAMPS

No. 864w.

Accurately made, nickel-plated, and will cramp from 9 in. upwards, and take in mouldings up to 3 1/4 in.
Each Cramp is supplied with 10 ft. of chain.

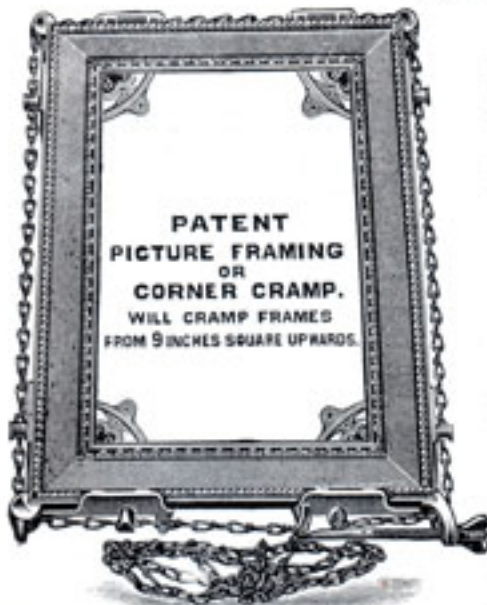

No. 1. Price, with 10 ft. Chain, 18/6 set.

Each set consists of Four Corner Cramps which have projecting lugs with holes through which the Chain passes and surrounds the entire frame. This Chain is operated upon by means of a hooked screw and fly nut. When the Chain is passed round the frame, the hook is inserted in any convenient link, and then screwed up tightly by means of the hooked screw and fly nut.

No. 2 is supplied with Top Corner Pressure Grips for pressing down the pieces of frame when nailing, and being fitted with rubber underneath, will not damage the moulding.

GARRIAGE FORWARD.

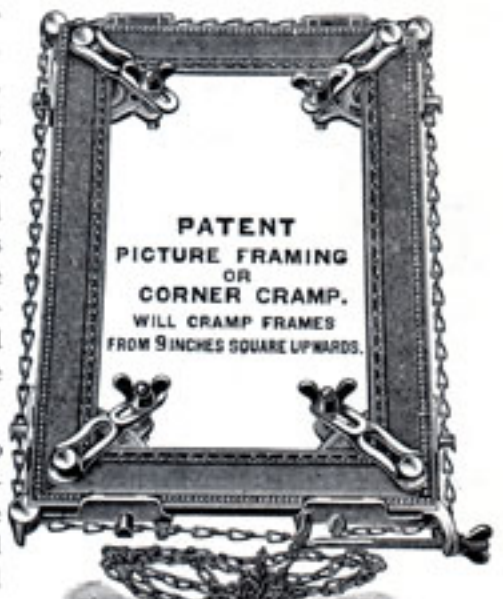

No. 2. Price, with Top Corner Pressure Grips and 10 ft. Chain, 22/6 set.

PICTURE FRAMING CRAMPS



No. 865w.
To take
1 1/4 in.
1/6 each.
No. 866w.
To take
2 in.
2/3 each.

No. 867w.
To take
4 in.
3/6 each.

ROLLER CRAMP
No. 868w.



Easy and simple to use. Perfect joints obtained without trouble. Cannot get out of order.
No. 1. Takes Mouldings up to 2 1/2 in. wide ... 5/6 each.
No. 2. Takes Mouldings up to 4 in. wide ... 7/- each.

IMPROVED CORNER CRAMPS
No. 869w.



Takes Mouldings 1 1/2 2 1/2 4 in.
Price ... 2/- 2/6 3/3 each.

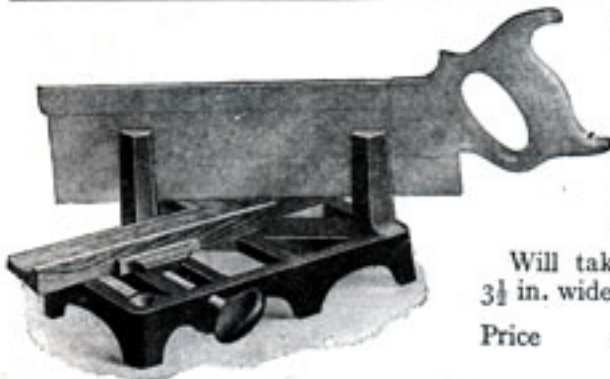

NEW MITRE MACHINE AND CRAMP COMBINED

No. 870w.

No loose parts. Easy and simple to work. Cannot get out of order.

Will take Mouldings up to 3 1/2 in. wide x 2 1/2 in. deep.

Price ... 13/- each.

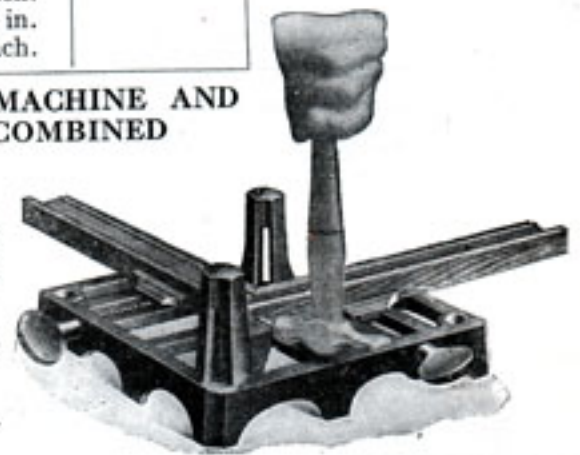

FOUR-CORNER CHAIN CRAMP

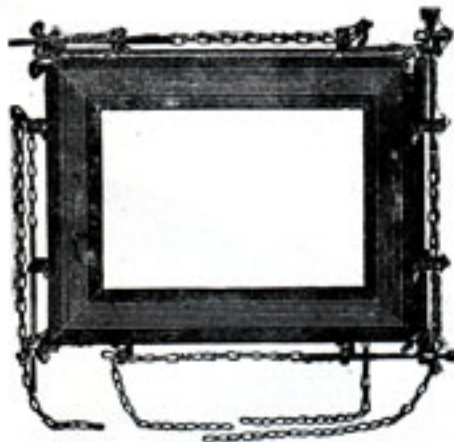

No. 871w.

This is effective, cheap, and thoroughly recommended. It will take any intermediate size and shape of frame to 33 x 27 in.

Complete, with four stops for holding down moulding.

Price ... 14/- each.

PATENT AMATEUR FRAMING CRAMPS

No. 872w.

These are made of Hardwood and cramp moulding in one operation. One grip has an iron ratchet for tightening the cord.

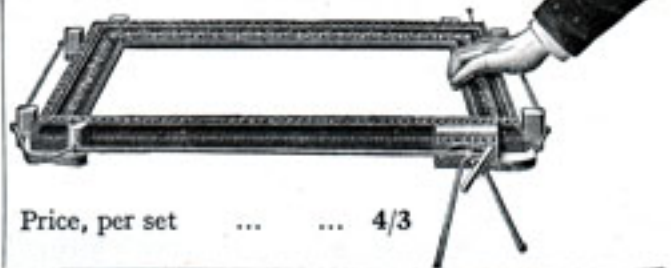

Price, per set ... 4/3

No. 873w.

MOUNT CUTTERS' HANDLES AND KNIVES

No. 874w.



Tool complete ... 2/-
Handle in Rosewood ... 1/3 each.
Blade only ... -/10 "

London Pattern, Ebony, complete with blade 5/6
Handle only ... 4/3 each.
Blade only ... 1/6 "

Builders' and Furnishing Ironmongery

MITRE BOXES

No. 875w.

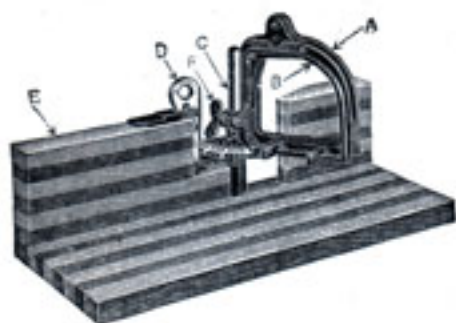

The saw guide can be instantly set and rigidly held by the set screw at any angle wanted. To facilitate such adjustment with accuracy, notice the projecting gauge points for setting against a "T," or angle bevel.

By means of the sliding key (exactly adjusted between bearings) the saw guide can be set to the angles more commonly used, indicated on the dial by the letters M, P, H, O, W, R, W, O, H, P, M, viz.: R, right angle or square cut; M, mitre, or 45°; P, Pentagon, or 36°; H, Hexagon, or 30°; O, octagon, or 22½°; W, to match usual door and window-sill pitch, 9°.

Any saw may be used—back saw, panel, or hand.

For cutting to exact depths, use a back saw, the back rib resting on the shoulders within the swinging guide: this guide, adjusted to the proper height, will determine the depth, at the same time that it keeps to the angle, to be cut.

A friction stop, operated by a strong spiral spring below the set screw, holds the saw guide from sliding down on the post.

The three screws in the arch of the saw guide control and adjust the diameter of the opening in which the saw moves, according to the thickness of the saw blade.

The guide is long, thus ensuring accuracy.

May be detached in a minute from the wood box and folded to carry in tool chest.

Price, as shown, 21/-

16 in. Panel Saw to suit, 7/6 extra.

STANLEY MITRE BOX

No. 876w.

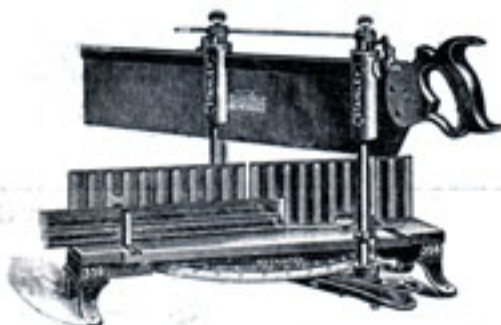

Frame in one piece, with detachable malleable legs. Strong, accurate, compact, durable, and possesses the following advantages: Saw is held above work when not in use. Swivel is automatically locked at any angle. Stock Guides for holding work in place or as length gauges for duplicating work. Extra wide range of work—will saw at angle of 30°.

No.	Saw.	Cuts at Mitre 45°.	Cuts at 30° without Guide.	Price, with Diston's Saw.
A	20 × 4 in.	5½ in.	3½ in.	£3 : 18 : 6
B	24 × 4 ..	5½ ..	3½ ..	£4 : 2 : 6
C	26 × 4 ..	6½ ..	4½ ..	£4 : 11 : 6
D	30 × 6 ..	7½ ..	5½ ..	£5 : 16 : 0

IMPROVED NEW LANGDON ACME MITRE BOX

Polished and Nickel-plated

No. 877w.

This is our most improved type of box, and has, in addition to the usual features, the guides an inch longer than usual and a graduated arc in front (see illustration). It also has a metallic index plate with degrees marked thereon, and the steel bottom boards are roughened to prevent work from slipping.

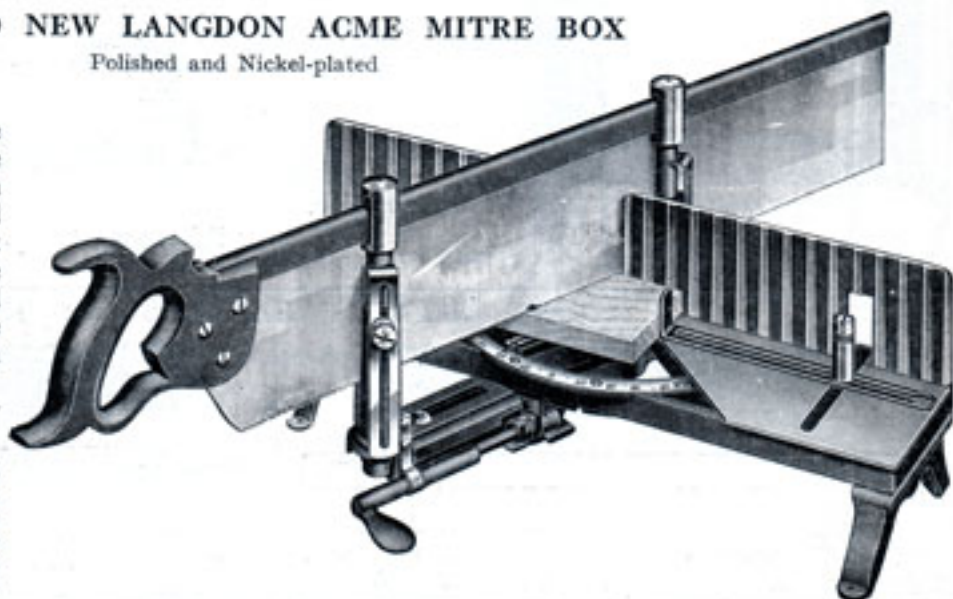

Saw.	Capacity at Right Angles.	Capacity at Mitre.	Price.
22 × 4 in.	7½ in.	5 in.	£3 : 16 : 0
24 × 4 ..	7½ ..	5 ..	£3 : 19 : 6
26 × 4 ..	7½ ..	5 ..	£4 : 2 : 9
22 × 4 ..	10½ ..	7 ..	£4 : 2 : 9
24 × 4 ..	10½ ..	7 ..	£4 : 5 : 3
26 × 4 ..	10½ ..	7 ..	£4 : 7 : 0

TOOL AND MACHINE MERCHANTS

PATENT ADJUSTABLE TEMPLATE

No. 878w.

WITH this ingenious device it is possible to obtain a profile of anything in a few seconds without using a file, shears, calipers, pencil, sheet brass or tin, and even to obtain the male and female profile in one operation, correct to .007 in.

It is composed of hundreds of very fine pieces of hard drawn solid brass, therefore rustless, the thickness of each being .007 in. These laminations are held in position by two aluminium clamps, secured by two thumbscrews and springs, by the tension of which the pieces of brass just take the shape of anything they are pressed against.

The illustrations herewith will make quite clear the ingenuity of the invention, and prove the great advantage of the tool.



No.	1	2	3	4	5	
Width	2	4	6	9	12	in.
Price	10/6	21/-	30/-	80/-	150/-	each.



IMPROVED SQUARE AND MITRE TEMPLATE

No. 879w.

Nickel-plated.
Size, 6 in.

Price ... 2/9 each.



BRASS MITRE TEMPLATE

No. 880w.

Size ... 3 1/4 4 1/2 6 in.

Price ... 2/- 3/3 4/6 each.



MITRE BOXES

No. 881w.

With Malleable Iron Guides adjustable to any gauge of saw. Takes mouldings up to 3 in. wide.

Price ... 4/6 each.

No. 881 1/2 w. To take up to 4 in. ... 5/6 ..



UNIVERSAL BRACE BIT HOLDER

No. 882w.

Boxwood Handle
with Set Screw.

Price ... 2/6 each.



MITRE BLOCKS

No. 883w.

Best quality Beech.

Length ... 9 12 16 in.

Price ... 1/- 1/3 2/- each.

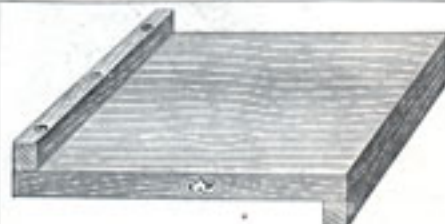

BEECHWOOD BENCH HOOK

No. 884w.

Dowelled ends.

Size, 10 x 6 x 1/2 in.

Price ... 2/9 each.

.. in Deal ... 2/3 ..

Electric and Wireless Engineers

**THE
"ECONOMICAL"
WOOD
TRIMMER**

No. 885w.

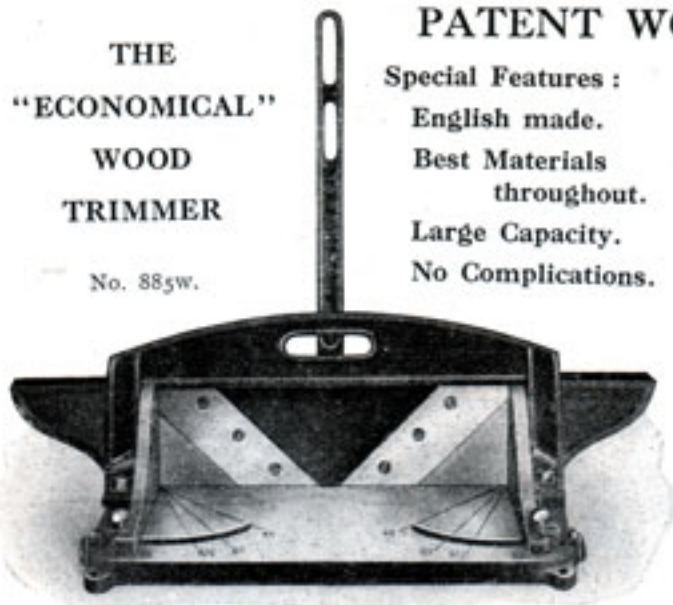

PATENT WOOD TRIMMERS

Special Features :
English made.
Best Materials
throughout.
Large Capacity.
No Complications.

No. 886w.

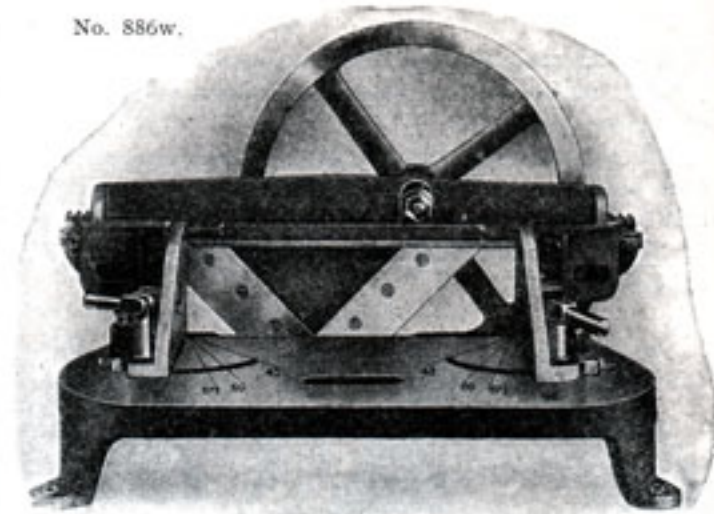

This is the same high-class manufacture as machine opposite. The knife slide is propelled by means of a flywheel and cut steel rack.

No.	Length of Cut.	Height of Cut.	Bed.	Weight.	Price
0	7 in.	4 in.	18 x 7 in.	30 lb.	£5 : 15 : 0
1	9 ..	5 ..	21 x 9 ..	56 ..	£8 : 10 : 0
2	11 ..	6 ..	27 x 11½ ..	115 ..	£11 : 10 : 0
3	13 ..	6 ..	29 x 13 ..	124 ..	£15 : 0 : 0

No.	Height of Cut.	Length of Cut.	Bed.	Weight.	Price.
1	4 in.	13 in.	22 x 9 in.	82 lb.	£13 : 0 : 0
2	4 ..	13 ..	22 x 9 ..	82 ..	£17 : 10 : 0

Angles on No. 1 Machine, 45°-90°; on No. 2, 45°-130°.

THE IMPROVED PATENT TRIMMER

English workmanship throughout, and fully warranted. In this design the flywheel is extra heavy and the knife slide is an oblong frame giving a 20 in. bearing.

No. 887w.

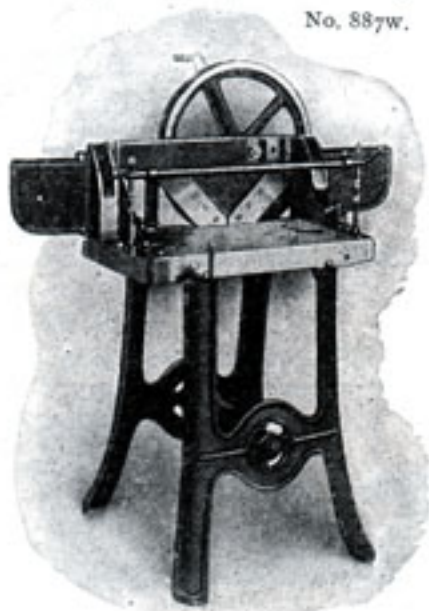

No.	Length of Cut.	Height of Cut.	Bed.	Weight.	Price.
1	20 in.	5½ in.	26 x 12 in.	390 lb.	£21 : 0 : 0
2	20 ..	4 ..	26 x 12 ..	360 ..	£20 : 0 : 0

Fitted with horizontal bar for cutting cornice moulds at any angle.

**PATENT
MITRE
CUTTERS**

Guaranteed to cut a true mitre of 45°.

No. 1. To cut mouldings to 2½ in. 25/-

No. 2. To cut mouldings to 4½ in. 37/6

Knives for No. 1, 7/6 per pair.

Knives for No. 2, 10/6 per pair.

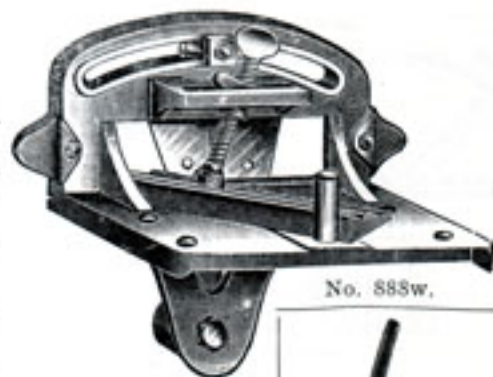

No. 888w.

**APPRENTICE MACHINE
ON STAND**

No. 889w.

No.	Length of Cut.	Height of Cut.	Bed.	Price.
1	9	4½	18 x 8 in.	£9 : 15 : 0
2	12	5½	23 x 10 ..	£14 : 10 : 0
3	16	6	23 x 10 ..	£18 : 10 : 0

Machines on this page
Carriage Forward.



Bronze Medal 1884—Gold Medal 1890

TOOL AND MACHINE MERCHANTS

IMPROVED PATTERN SHOOTING BOARDS No. 890w.

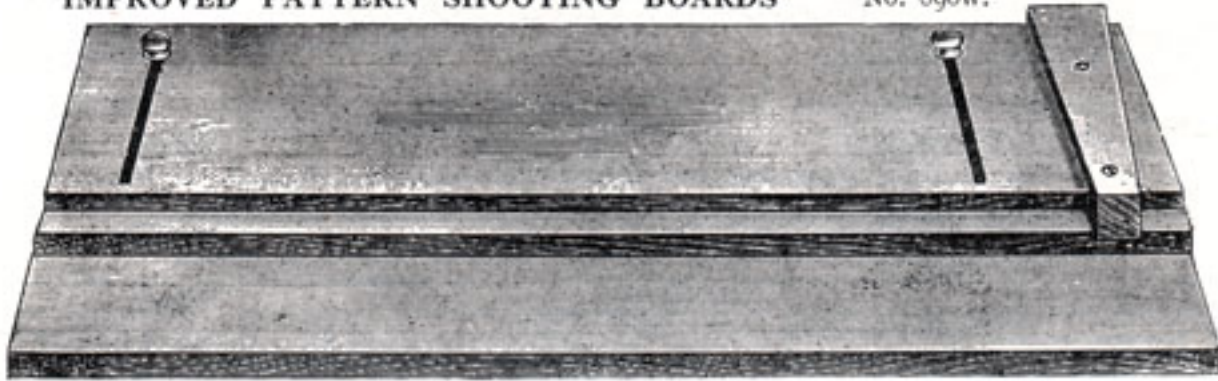

Improved Pattern Shooting Board with Adjustable Parallel Sliding Fence, most useful for squaring the edges of boards and joints before gluing, and many other purposes.

Price, as illustrated, in Pine, 3 ft. long... 14/- each. In Selected Oak 25/- each.
 „ without Adjustable Fence, 3 ft. long 11/- „ „ „ 19/6 „

MITRE SHOOTING BOARD

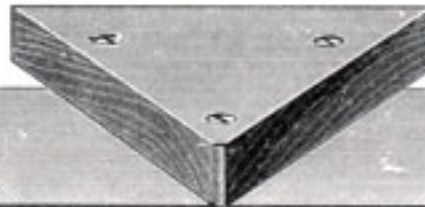

No. 891w.

Improved pattern with mortised joints and outlet for shavings.

Price, in Pine 24 36 in. long. 36 in. long.
 8/6 11/- each. Price, in Selected Oak 21/- each.

The above Shooting Boards are made on the premises by our own experienced cabinet makers. We shall be pleased to quote for larger sizes on application.

For planing at any desired angle on straight or curved work. The plane runs on a way at rear of bed plate, and the material to be planed is guided by the movable quadrant swinging on pivot A. When the quadrant is in the centre of bed plate its side elevations form an exact mitre, so that no change is required in planing the ends of parts for frames of four sides. In the sides of the quadrant are two adjustable guides or rests, kept in position by set screws D, D. The special objects of these rests is to enable one to finish the ends or angles on curved work with exactness.

In preparing pieces for circular or oval work, frames, emery wheels, circular patterns, etc., it is necessary to plane the ends of the various segments at varying angles. In planing these, the point of the quadrant, near the plane, and the adjustable guides form the rests required for accurate work.

IMPROVED MITRE PLANER

No. 892w.

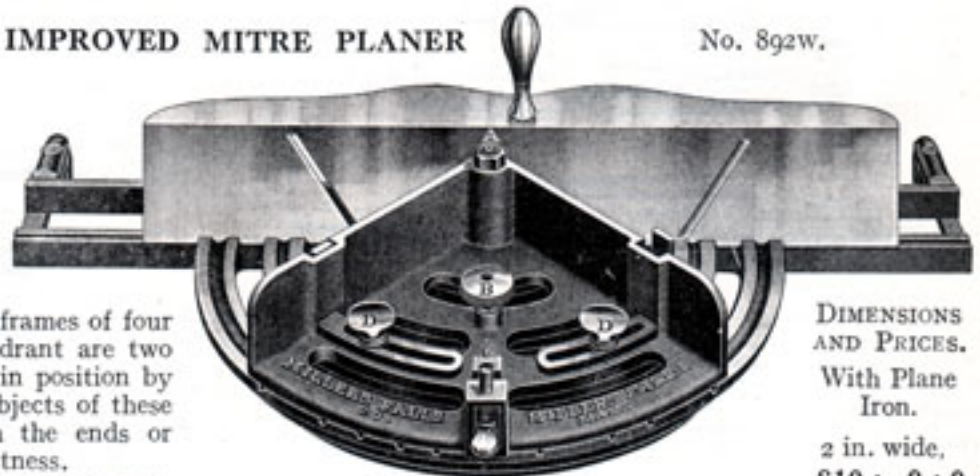

DIMENSIONS AND PRICES.

With Plane Iron.
 2 in. wide, £10 : 0 : 0
 3½ in. wide, £15 : 10 : 0

Export Orders have the attention of our experienced men, and a wide knowledge of the various manufactures enables us to execute all foreign orders and commissions effectively and satisfactorily. We are always pleased to receive communications from our clients abroad.—R. MELHUISE, LTD., London, E.C.

Engineers' Tools and Machinery

WOOD-CARVING TOOLS

No. 893w.

S. J. ADDIS' celebrated make, as supplied to Carving Schools throughout the Country.

SPECIAL TERMS TO TECHNICAL CLASSES.

We hold the largest and best selected stock of Carving Tools in the trade.
Every size and section kept in stock ready for immediate delivery.

All patterns advance by sixteenths up to $\frac{1}{2}$ in., and then by eighths.

PLEASE NOTE.—The prices given herewith are for Carving Tools ground to a sharp edge, but not "set." It will be recognised that it is not possible to keep Tools in stock with specially finished edges without damaging them. As many of our customers prefer to set and buff their own Carving Tools, we send them out (unless ordered otherwise) ground to a sharp edge.

We have an improved method of buffing and setting Carving Tools, and charge at the rate of 2/- per dozen extra.
Instructors of Technical Classes wishing to grind their own Tools can be supplied in quantities at special prices.

FIRMERS



From $\frac{1}{4}$ in. and all sizes up to $\frac{1}{4}$ $\frac{1}{2}$ $\frac{3}{4}$ 1 1 $\frac{1}{2}$ 2 $\frac{1}{2}$ in.
Price 1/- 1/2 1/4 1/5 1/8 2/- each.

STRAIGHT GOUGES

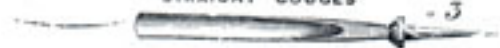

Sizes from $\frac{1}{4}$ in. to $\frac{1}{4}$ $\frac{1}{2}$ $\frac{3}{4}$ 1 1 $\frac{1}{2}$ 2 $\frac{1}{2}$ in.
Price 1/3 1/4 1/6 1/7 1/8 2/- each.



Sizes from $\frac{1}{4}$ in. to $\frac{1}{4}$ $\frac{1}{2}$ $\frac{3}{4}$ 1 1 $\frac{1}{2}$ 2 $\frac{1}{2}$ in.
Price 1/4 1/4 1/6 2/- 2/4 2/8 3/- each.



Sizes from $\frac{1}{4}$ in. to $\frac{1}{4}$ $\frac{1}{2}$ $\frac{3}{4}$ 1 1 $\frac{1}{2}$ 2 $\frac{1}{2}$ in.
Price 1/4 1/6 2/- 2/2 2/8 3/4 3/10 each.

We carry a stock of extra Flat Gouges, No. 21. Prices as No. 3.

CURVED GOUGES.



Sizes from $\frac{1}{4}$ in. to $\frac{1}{4}$ $\frac{1}{2}$ $\frac{3}{4}$ 1 1 $\frac{1}{2}$ 2 $\frac{1}{2}$ in.
Price 1/6 1/6 1/8 2/2 2/6 3/- 3/4 each.



Sizes from $\frac{1}{4}$ in. to $\frac{1}{4}$ $\frac{1}{2}$ $\frac{3}{4}$ 1 1 $\frac{1}{2}$ 2 $\frac{1}{2}$ in.
Price 1/6 1/9 2/3 2/6 3/- 3/4 4/- each.

BENT CHISELS.

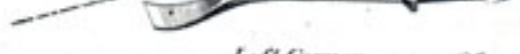

Sizes from $\frac{1}{4}$ in. to $\frac{1}{4}$ $\frac{1}{2}$ 1 1 $\frac{1}{2}$ 2 $\frac{1}{2}$ in.
Price 1/3 1/7 2/2 2/6 3/- each.

Builders' and Furnishing Ironmongery

TOOL AND MACHINE MERCHANTS

CARVING TOOLS (continued).

FRONT BENT GOUGES. No. 24

Sizes $\frac{1}{2}$ in. to ... $\frac{1}{6}$ $\frac{1}{8}$ $\frac{1}{2}$ $\frac{1}{6}$ $\frac{1}{4}$ $\frac{1}{3}$ in.
 Price ... $1/6$ $1/8$ $2/2$ $2/6$ $3/-$ $3/3$ each.

FRONT BENT GOUGES. No. 24 (continued)

Sizes $\frac{1}{2}$ in. to ... $\frac{1}{6}$ $\frac{1}{9}$ $\frac{1}{2}$ $\frac{1}{6}$ $\frac{1}{4}$ $\frac{1}{3}$ in.
 Price ... $1/6$ $1/9$ $2/2$ $3/-$ $3/4$ $4/-$ each.

BACK BENT GOUGES. No. 33

Sizes $\frac{1}{2}$ in. to ... $\frac{1}{6}$ $\frac{1}{8}$ $\frac{1}{2}$ $\frac{1}{6}$ $\frac{1}{4}$ $\frac{1}{3}$ in.
 Price ... $1/6$ $1/8$ $2/2$ $2/6$ $3/-$ $3/3$ each.

BENT SPADE CHISEL No. 101.

BENT SPADE GOUGE No. 104.

Prices:

No. 101 ...	$\frac{1}{1}$	$\frac{1}{1}$	$\frac{1}{1}$	$\frac{1}{1}$	$\frac{1}{1}$	$\frac{1}{1}$	$\frac{1}{2}$ each.
" 104 ...	$\frac{1}{3}$	$\frac{1}{3}$	$\frac{1}{3}$	$\frac{1}{3}$	$\frac{1}{3}$	$\frac{1}{3}$	$\frac{1}{4}$..

PARTING TOOLS. No. 39

All sizes up to ... $\frac{1}{6}$ $\frac{1}{2}$ $\frac{1}{8}$ $\frac{1}{4}$ $\frac{1}{4}$ in.
 Price ... $1/6$ $2/2$ $2/8$ $3/4$ $4/-$ each.

PARTING TOOLS. No. 39 (continued)

All sizes up to ... $\frac{1}{2}$ $\frac{1}{4}$ $\frac{1}{2}$ $\frac{1}{6}$ $\frac{1}{4}$ in.
 Price ... $2/-$ $2/4$ $3/-$ $3/6$ $4/3$ each.

SQUARE SPADE CHISEL No. 96.

SKREW SPADE CHISEL No. 97.

STRAIGHT SPADE GOUGE No. 98.

Prices:

No. 96 ...	$\frac{1}{1}$	$\frac{1}{1}$	$\frac{1}{1}$	$\frac{1}{1}$	$\frac{1}{1}$	$\frac{1}{1}$	$\frac{1}{1}$ in.
" 97 ...	$1/-$	$1/-$	$1/-$	$1/-$	$1/-$	$1/1$	$1/1$ each.
" 98 ...	$1/-$	$1/-$	$1/-$	$1/-$	$1/-$	$1/1$	$1/1$..

SPADE "V" PARTING TOOL No. 106.

No. 106 ... $\frac{1}{5}$ $\frac{1}{5}$ $\frac{1}{5}$ $\frac{1}{5}$ $\frac{1}{5}$ $\frac{1}{5}$ $\frac{1}{5}$ in.
 Price ... $1/5$ $1/5$ $1/5$ $1/5$ $1/5$ $1/5$ $1/6$ each.

RICHARD MELHUIH LIMITED, LONDON, E.C.



SET OF TWELVE SPADE CARVING TOOLS

No. 894w.

In Beech Handles to $\frac{1}{2}$ in.

Price 13/- per set.



SET OF TWELVE LADIES' HANDLED CARVING TOOLS, IN CLOTH-LINED CANVAS ROLL

No. 895w.

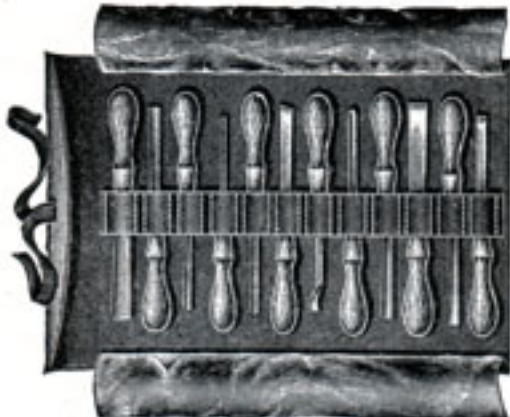

Number of Tools in each set ... 12 18 24
 Price 27/6 35/- 50/-

CHIP CARVING RACK No. 896w.



Polished Pine Rack, with 5 Tools, Mallet, Punch, Cramp, Bent Knife, Oilstone, Compass, Sheet of Designs, etc.

Price ... 18/- each complete.

SOUTH KENSINGTON SET LADIES' CARVING TOOLS, IN POLISHED PINE BOX

No. 897w.



Number of Tools in each set 7 12
 Price... .. 17/- 22/6
 Set of 12 in Cardboard Box 19/9

WOOD CARVERS' OUTFIT

No. 898w.



Polished Pine Lock-up Box, 16 x 15 x 3 in., with 12 Hardwood Handled Tools, Mallet, 2 Punches, Book of Designs, 2 Cramps, Router, Riffler File, Set of Arkansas Slips, Block Plane, Glue Kettle, Brass Back Saw, Awl, Boxwood Rule, Turnscrow, Hanging Plates and Screws, etc. Price ... 55/- each complete.

NOTE.—All Knives illustrated are of best quality English manufacture.

WOOD CARVERS' KNIVES

No. 899w.

No. 900w.



Price 1/3 each.

Price 1/- each.

No. 901w.

No. 902w.



Price 1/3 each.

Price 1/9 each.

No. 903w.



Price 1/3 each.

No. 904w.

No. 905w.



Price 1/3 each.

Price 1/3 each.

Electric and Wireless Engineers

TOOL AND MACHINE MERCHANTS



RIFFLERS, FOR CARVING AND OTHER PURPOSES

No. 906w.
Nos. A to H, with Rasp one end and File the other. Length, 7 in.
Price 1/9 each.

CARVERS' SCREWS

No. 907w.



With Black Wing Nut.

Size $8 \times \frac{1}{2}$ $10 \times \frac{1}{2}$ in.
Price 5/- 6/- each.

CARVERS' MALLETS

No. 908w.
Polished Beech.



3 in. 2/3 each.
3 1/2 in. 2/6 each.
4 in. 3/- each.

CARVERS' PUNCHES

No. 909w.



Price -/9 each.



SETS OF LADIES' HANDLED CARVING TOOLS IN POLISHED PINE BOX

No. 910w.
Set of 12, 24/-
Set of 24, 50/-

MATERIAL FOR BENT IRON WORK, STRIP IRON, COPPER, AND BRASS

Widths of Stock Sizes. In 24 in. lengths. No. 911w.

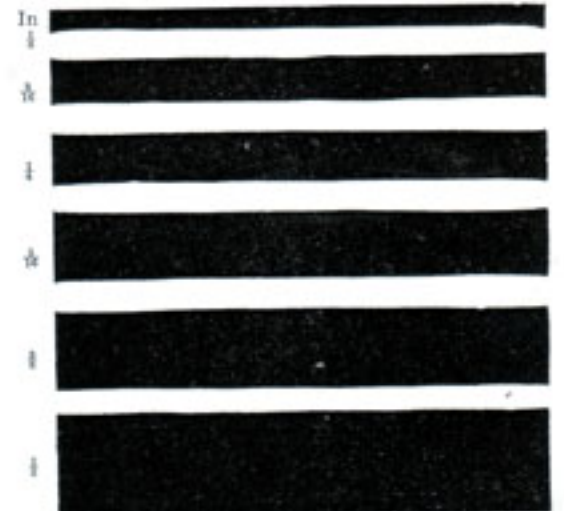

The Copper and Brass are beautifully polished by machinery, and will be found to be quite as pliable as our well-known Strip Iron. As these highly polished metals are very quickly tarnished by the atmosphere and hot hands, they should be lacquered at the earliest opportunity. Until this is done, or before using, it should be kept well wrapped up.

Best Quality Strip Iron, $\frac{1}{8}$, $\frac{3}{16}$, $\frac{1}{4}$, $\frac{5}{16}$, $\frac{3}{8}$, $\frac{1}{2}$ in. ... 2/- lb.
Copper or Brass, $\frac{1}{8}$ to $\frac{1}{2}$ in. wide... 4/- ..
Framing Iron, $\frac{1}{2}$, $\frac{3}{4}$ in. -/8 ..



ARKANSAS CARVING TOOL SLIPS

No. 912w.
Per set of 4, 5/6.

Bronze Medal 1884—Gold Medal 1890

RICHARD MELHUISSH LIMITED, LONDON, E.C.



No. 913w. **No. 1 Quality Washita.**
 Size 8 x 2 x 1 in. Price 3/- each.

Other sizes in this quality obtained to order quickly.

WASHITA OILSTONES No. 914w.

Lily White Washita is the best selection of Washita possible to obtain. It is uniform in texture, free from foreign substance, and is nicely finished. It is the most satisfactory natural grit Oilstone ever produced for carpenters' and general woodworkers' tools.

Size .. *8 x 2 x 1 *9 x 2 x 1 in.
 Price .. 3/9 4/6 each.

* Approximate sizes.

WASHITA OILSTONES No. 1 Quality

Mounted in Polished Boxes, all 2 in. wide.

Size...	6	7	8	9	in.
Price	2/6	3/-	4/-	5/-	each.

Lily White grade of Washita Stone quoted for on application.



No. 915w.

SELECTED TURKEY STONES



No. 916w.

Size about ... 8 x 2 x 1 9 x 2 x 1 in.
 Price ... 5/6 6/6 each.
 No. 916 1/2 w. Turkey Slips. Price 1/-, 1/3, 1/6 ea.



WASHITA WHEELS

No. 917w.

Size... 2 x 1/2 2 1/2 x 1/2 3 x 1 in.
 Price 6/6 8/6 12/6 each.

RAZOR HONES

These Honers are superior to others for sharpening razors and other fine instruments. They possess a very fine satin grit and are generally preferred to any other hone by the leading cutters and razor manufacturers throughout the world.

No. 919w.



Length	...	5	6	7	8	in.
First quality	...	3/-	4/6	7/6	12/6	each.
Second	..	2/6	3/6	6/6	10/9	..

No. 918w.

WASHITA SLIPS



Size 3 1/2 x 4 1/2 4 1/2 x 5 1/2 in.
 Price 1/3 1/6 each.

No. 920w.



In Polished Mahogany Boxes with Hinged Lids. Honers of special value. Length

Length	4	5	6	7	in.
Price	2/6	4/-	4/6	6/6	each.



BEST CANADA STONE

No. 921w.
 Length, 8 in.
 Price 1/3 each.

"MIKADO" STONE

No. 922w.

Suitable for Machine Plane Irons.
 Length, 8 x 2 x 1 1/2 in. Price 2/6 each.

WATER OF AYR STONE

No. 923w.

Prices -/10, 1/3, and 1/6 each.



QUICK CUT EMERY OILSTONES

No. 924w.
 One side Coarse and the other Medium.
 Size 8 x 2 x 1 in. Price 1/6 each.

"SILVER GRIT" STONE

No. 925w.

Similar to the "Mikado." Fast cutting.
 Size 8 x 1 1/2 x 1/2 in. approx.
 For use with water. Price 1/6 each.

TOOL AND MACHINE MERCHANTS

CARBORUNDUM STONES

No. 926w.



No.	Length, In.	Width, In.	Thick-ness, In.	Grade.	Price, each.
288	8	1 1/2	1 1/2	Md. Fine	6/3
115	8	2	1	Fine	5/3
116	8	2	1	Medium	5/3
118	8	2	1	Fine	4/9
119	8	2	1	Medium	4/9
121	6	2	1	Fine	4/-
122	6	2	1	Medium	4/-
124	6	2	2	Fine	3/3
125	6	2	2	Medium	3/3
130	6	1 1/2	1 1/2	Fine	2/6
131	6	1 1/2	1 1/2	Medium	2/6
133	7	2	2	Fine	4/6
134	7	2	2	Medium	4/6
136	5	2	2	Fine	2/9
137	5	2	2	Medium	2/9
142	4	1 1/2	1 1/2	Fine	2/3
143	4	1 1/2	1 1/2	Medium	2/3
145	4	1	1	Fine	1/6
146	4	1	1	Medium	1/6

No. 928w.



CARBORUNDUM MACHINISTS' SPECIAL

This Stone is especially designed for machinists' use. It is a fast-cutting stone and holds its shape perfectly. The grit and the grade of hardness is adapted to sharpening lathe and planer tools, milling cutters, reamers, and drills. Oil or water may be used without injurious effect to stone or cutting qualities.

- No. 292. 4 x 1 x 1/2 in., FF grit, fine.
 Price 2/- each.
- No. 292 M. 4 x 1 x 1/2 in., medium grit.
 Price 2/- each.



SHARPENING STONES

Positively unequalled for rapid-cutting qualities. Used dry or with water or oil. Are quite porous, and may be tempered in their cutting by filling with wax or vaseline.

No. 929w.



COMBINATION STONES

MADE IN EIGHT SIZES.

These Stones are designed especially for carpenters and mechanics.

They are made with one face of coarse and one face of very fine grit. The coarse side can be used for sharpening dull tools; the fine side for giving required keen, lasting edge.

No.	Dimensions	Price, each.
No. 108.	8 x 2 x 1 in.	6/3
.. 109.	6 x 2 x 1 ..	4/6
.. 110.	7 x 2 x 1 ..	5/3
.. 111.	5 x 2 x 3/4 ..	3/6
.. 112.	4 x 1 1/2 x 1 ..	3/-
.. 328.	8 x 3 x 1 ..	8/-
.. 329.	9 x 3 x 1 1/2 ..	11/6
.. 333.	12 x 2 1/2 x 1 ..	10/9

Thickness.	4 in. long.				6 in. long.			
1/2 in.	1/9	2/3	2/3	2/6	2/6	3/-	3/-	3/6 each.
3/4 ..	1/9	2/3	2/3	2/6	2/6	3/-	3/-	3/6 ..
1 ..	1/9	2/3	2/3	2/6	2/6	3/-	3/-	3/6 ..
1 1/4 ..	2/-	2/6	2/6	2/9	2/9	3/6	3/6	3/9 ..
1 1/2 ..	2/-	2/6	2/6	2/9	2/9	3/6	3/6	3/9 ..
1 3/4 ..	2/3	2/9	2/9	3/-	3/-	3/9	3/9	4/- ..

No. 927w.



SLIP STONES

MADE IN TWO GRITS.

Are made in five sizes and two different grits of each size. These Slip Stones cut rapidly and hold their shape perfectly.

No.	Length, In.	Width, In.	Thick-ness, In.	Grade.	Price, each.
174	6	2 1/2	1/2	Fine	4/-
175	6	2 1/2	1/2	Medium	4/-
177	4 1/2	1 1/2	1/2	Fine	2/3
178	4 1/2	1 1/2	1/2	Medium	2/3
180	4 1/2	2 1/2	1/2	Fine	3/3
181	4 1/2	2 1/2	1/2	Medium	3/3
183	4 1/2	1 1/2	1/2	Fine	2/3
184	4 1/2	1 1/2	1/2	Medium	2/3
186	4	1	1/2	Fine	2/-
187	4	1	1/2	Medium	2/-

No. 930w.



Set of 4 Slips for carving tools, price 6/-; Single Slip, 1/6 each.

STICKS

No. 931w.

Shapes as below.

In ordering above, kindly give Nos. 926w/288, etc.

For a more comprehensive display of Carborundum Stones, Grinders, etc., kindly refer to Metal List.

Builders' and Furnishing Ironmongery

INDIA OILSTONES

No. 932w.

THESE are made from "Alundum," a remarkable reproduction of one of the minerals of nature—corundum. The advantages of "Alundum" over every other known abrasive material lie in its peculiar combination of hardness, sharpness, and temper. By temper is meant strength of grain and the character of its fracture under sharpening pressure.

India Stones, therefore, possess the characteristics of hardness, sharpness, and toughness, and, in addition to these qualities, they also possess absolute uniformity. They cut more rapidly, last longer, and keep a better surface than any other artificial stone, and are a necessary factor wherever edge tools are used. They are especially adaptable for the quick sharpening of all kinds of machinists' tools made of modern tool steels, such as scrapers, taps, reamers, milling cutters, lathe and planer tools.

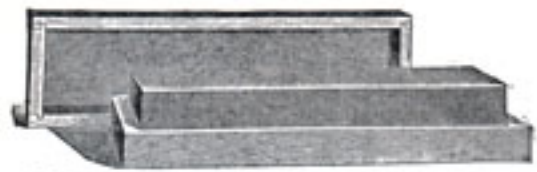
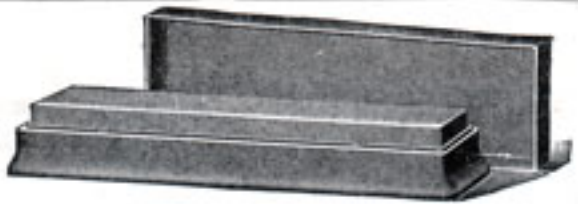
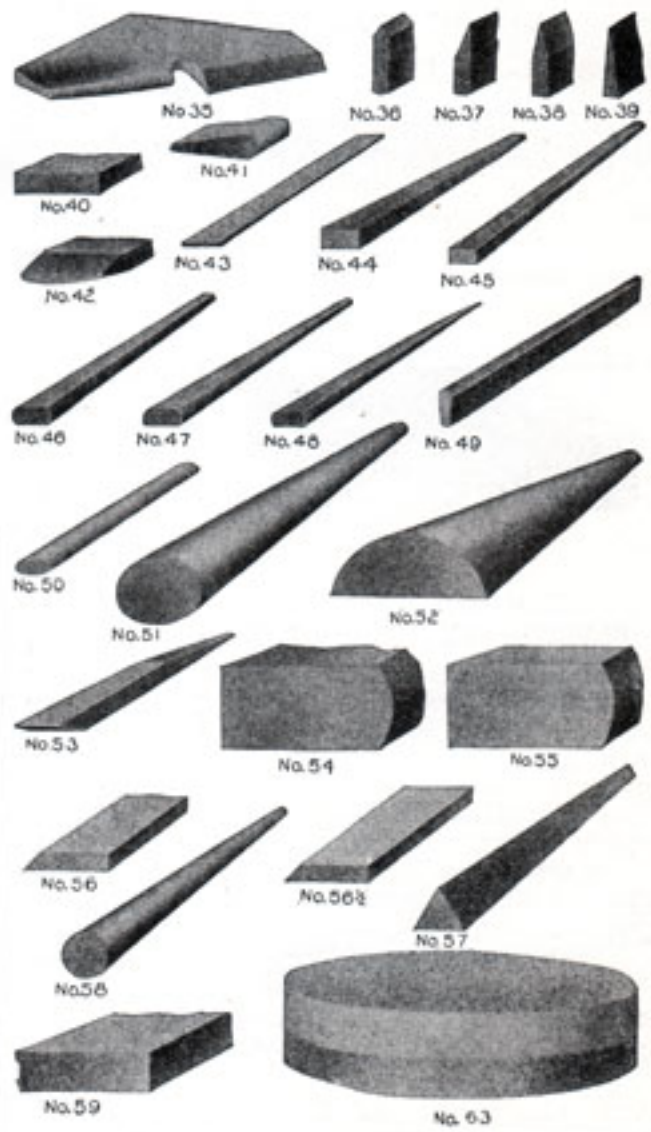
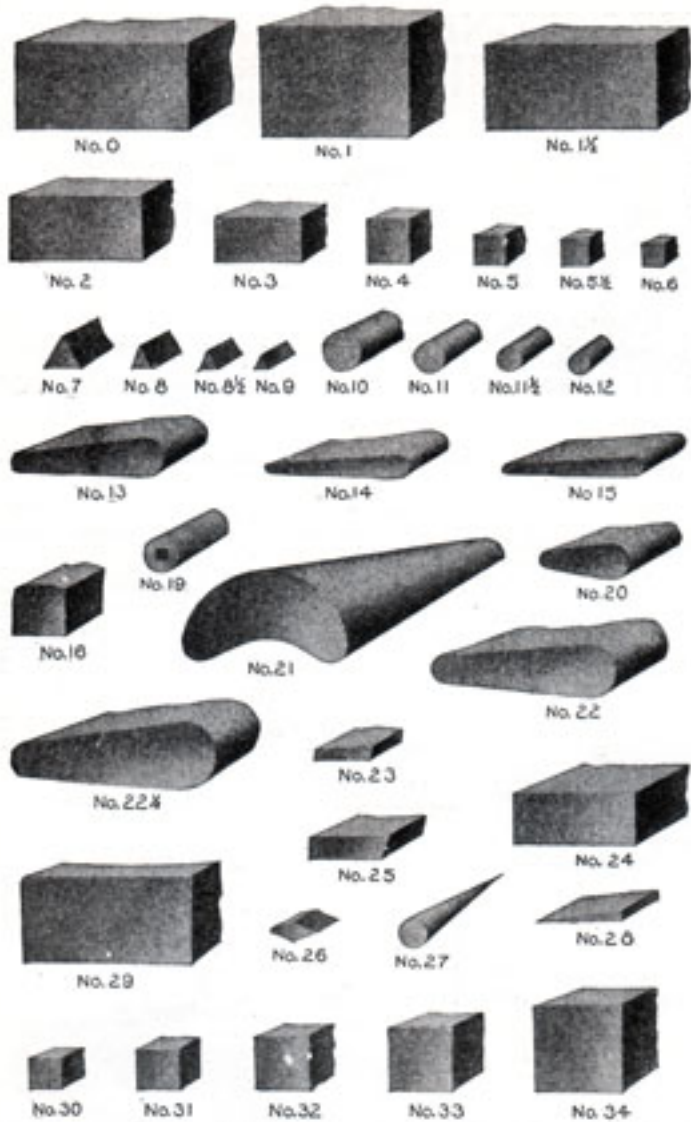

MOUNTED INDIA OILSTONES

No. 933w. No. 934w.

Size, 8 x 2 x 1 in. ...	In Wood Box.	In Iron Box.
" 8 x 1 1/2 x 1 1/2 " ...	7/11	9/3
" 7 x 2 x 1 " ...	9/-	10/-
" 6 x 1 1/2 x 1 " ...	6/11	8/6
" 6 x 1 1/2 x 1/2 " ...	5/10	7/4

Medium and Fine, same price.

For prices of Stones Nos. 0-63, see next page.
Kindly order India Stones thus: No. 932w/0, etc.

TOOL AND MACHINE MERCHANTS

PRICES OF INDIA STONES ILLUSTRATED OPPOSITE

Shape.	Dimensions.	Price, each. Medium and Fine.	Shape.	Dimensions.	Price, each. Medium and Fine.
0	8 x 2 x 1	6/3	36		
1	8 x 1 1/2 x 1 1/2	7/4	37	1 Set (4) Carvers' Slips, 2 1/2 x 1/2 x 1/8	8/4
1 1/2	7 x 2 x 1	5/3	38		
2	6 x 1 1/2 x 1/2	4/2	39		
3	4 x 1 x 1/2	2/6	40	2 x 1 x 1/2	2/1
4	Square File 4 x	2/1	41	5 x 1 x 1/2 x 1/2	2/11
5	" " 4 x	2/1	42	4 x 1 x 1/2	3/2
5 1/2	" " 4 x	2/1	43	4 x 1/2 x 1/2	3/2
6	" " 4 x	2/1	44	4 x 1/2 x 1/2 x 1/2	3/2
7	Triangular File 4 x	2/9	45	4 x 1/2 x 1/2 x 1/2	3/2
8	" " 4 x	2/9	46	4 x 1/2 x 1/2 x 1/2	3/2
8 1/2	" " 4 x	2/9	47	4 x 1/2 x 1/2 x 1/2	3/2
9	" " 4 x	2/9	48	4 x 1/2 x 1/2 x 1/2	3/2
10	Round File 4 x	2/11	49	4 x 1/2 x 1/2 x 1/2	3/2
11	" " 4 x	2/11	50	3 1/2 x 1/2 x 1/2	3/7
11 1/2	" " 4 x	2/11	51	Oval Plug 6 x 1/2 x 1/2	4/7
12	" " 4 x	2/11	52	Heel Breast Stone 6 x 2 x 1/2	2/11
13	4 1/2 x 1 1/2 x 1/2 x 1/2	2/9	53	Automobile Stone	2/9
14	4 1/2 x 1 1/2 x 1/2 x 1/2	2/9	53	" " " in Case	3/2
15	4 1/2 x 1 1/2 x 1/2 x 1/2	4/2	54	8 x 2 " " High Round	6/3
16	8 x 1/2 x 1/2	4/7	54 1/2	5 x 1 1/2 x 1/2	4/2
19	(Engravers' Pencils, Fine one end, Medium the other)	2/1	55	4 x 1 1/2 x 1/2	2/1
20	4 x 1 x 1/2 x 1/2	2/9	56	5 x 1 x 1/2 (Reamer Stone)	3/2
*21	6 x 2 x 1 x 1/2 x 1/2	6/3	56 1/2	6 x 1 x 1/2	3/2
22	4 1/2 x 2 1/2 x 1/2 x 1/2	4/2	57	4 x 1/2 x 1/2	3/2
22 1/2	6 x 2 1/2 x 1/2 x 1/2	1/8	58	4 x 1/2 x 1/2	3/7
23	3 1/2 x 1/2 x 1/2 x 1/2	2/1	59	(3 x 1 1/2 x 1/2 Axe Stone, Coarse Grit only)	1/11
24	4 1/2 x 1 1/2 x 1/2	3/2	60	Circular Axe Stone 3 x 1/2	3/2
24	4 1/2 x 1 1/2 x 1/2 Combination	1/8	61	3 1/2 x 1 x 1/2	4/2
25	4 1/2 x 1 x 1/2 Reamer Stone	2/1	62	Sportsmen's Stone 3 x 1 1/2 x 1/2	4/7
26	4 x 1/2 x 1/2	3/9	63	Circular Comb 4 x 1	6/11
27	3 x 1/2 Points	3/9	63	Above in Steel Box	11/1
28	4 x 1 x 1/2	2/11	64	Triangular File 6 x 1/2	3/7
29	6 x 2 x 1	4/10	65	" " 6 x 1/2	4/-
30	Square File 6 x	2/11	66	" " 6 x 1/2	4/-
31	" " 6 x	2/11	67	" " 6 x 1	4/7
32	" " 6 x	2/11		Engravers' Chuck	5/3
33	" " 6 x	3/7		Points 1 x 1/2, per doz.	6/1
34	" " 6 x 1	3/7	68	4 1/2 x 1/2 x 1/2	1/6
35	Bath Universal Slip	10/5			

* No. 21 made in special fine only.

† No. 52 made in medium fine only.



COMBINATION INDIA OILSTONES

No. 935w.

These Stones have one face medium and one face coarse grade. The coarse side can be used for sharpening dull tools, or tools where fast work is required without regard to fine finish, while the medium size can be used when a finer edge is required, or for finishing after the coarse side has been used.

Size ...	4 x 1 x 1/2	6 x 1 1/2 x 1/2	6 x 2 x 1	7 x 2 x 1	8 x 1 1/2 x 1 1/2	8 x 2 x 1 in.
Price ...	3/6	5/6	6/3	7/3	9/3	8/- each.



THREE IN ONE OIL

No. 936w.

A favourite oil with a great number of practical workmen. It does not clog or dry up.

Price in bottles ... -/9 and 1/6
 .. tin can 1/6

PIKE OIL

No. 937w.

The best oil for Oilstones, Razor Hones, Razor Stropps, Tool Grinders and Small Machinery.

Price in 3 ounce tins, 1/3.



RICHARD MELHUISH LIMITED, LONDON, E.C.

UNMOUNTED GRINDSTONES

No. 938w.

Turned Ready for Use.

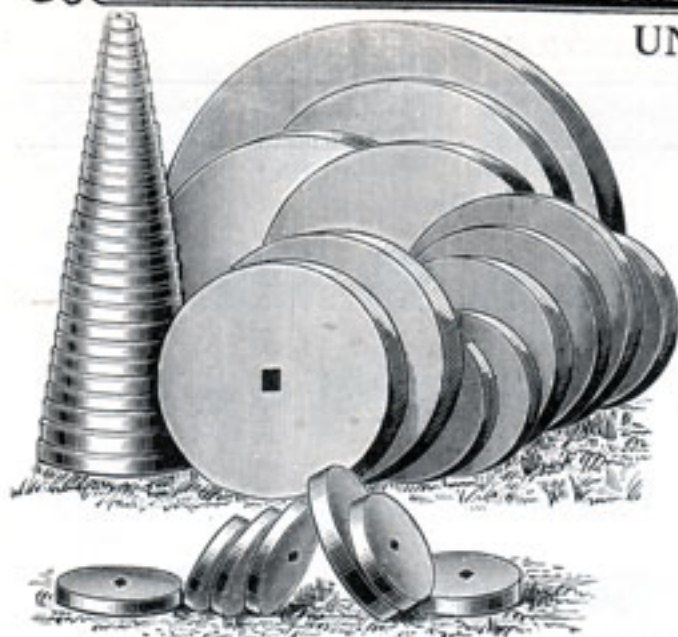

Size.	Best York.	Blue Grit Bilston.
6 × 2 in.	2/- each.	3/6 each.
8 × 2 " " " " " "	2/9 "	4/9 "
10 × 2 " " " " " "	3/6 "	6/- "
12 × 2-3 " " " " " "	4/9 "	7/6 "
14 × 2-3 " " " " " "	5/6 "	9/6 "
18 × 2-3 " " " " " "	7/6 "	13/6 "
20 × 3½ " " " " " "	12/6 "	18/- "
24 × 4 " " " " " "	17/6 "	28/- "
26 × 4 " " " " " "	21/- "	33/- "
28 × 4 " " " " " "	24/6 "	47/6 "
30 × 5 " " " " " "	35/- "	55/- "
36 × 6 " " " " " "	61/- "	95/- "

Quotations for Larger Sizes on Application.
At Owner's Risk. Carriage Forward.

ARKANSAS STONES

An excellent hard stone for producing a very keen edge on tools, especially those used by engravers, surgeons, dentists, etc.

ARKANSAS BEVELLED GOUGE SLIPS No. 939w.



Size	3-4	4-4½	4½-5 in.
Price	2/-	2/3	2/6 each.

ARKANSAS BENCH STONES No. 940w.



Size	4 × 2 × 1	5 × 2 × 1	6 × 2 × 1	8 × 2 × 1 in.
Unmounted ..	7/6	12/9	22/6	30/- each.
Mounted	—	11/6	16/6	22/- "

ARKANSAS SQUARES No. 941w.



Size	½	¾	1 in.
Price	1/9	2/-	2/6 each.

Length, 3-4 in. Triangular Stones at same prices.

ARKANSAS NEEDLE POINTS

No. 942w.



Size, 3-5 in. long; ¼ in. at thick end. 1/6 and 2/- each.

JOINERS' NAME STAMPS, BRANDS, ALPHABETS, ETC.

NAME STAMP FOR WOOD

No. 943w.



Size of Letters, 3/32 or 1/8 in.
Price -/4 per letter.

No. 944w.

Heavier make for Stamping Steel.

Size	3/32	1/8	5/32	3/16 in.
Price	-/8½	-/9	-/10	1/- per letter.

Speciality.—Stamps made to customers' designs at lowest rates.

BURN BRAND FOR WOOD

No. 945w.

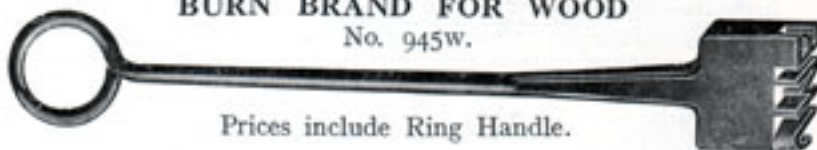

Prices include Ring Handle.

Size	2 letters	3 letters	4 letters	5 letters	6 letters	7 letters	8 letters	9 letters	10 letters	11 letters	12 letters
3/6	4/6	5/-	6/-	7/6	8/6	9/-	10/6	11/-	12/-	13/6	14/6
4/-	5/6	6/3	8/6	9/-	10/6	13/6	13/6	14/6	16/-	17/6	18/6
4/6	6/-	8/6	10/-	11/-	13/6	15/6	16/6	19/6	22/-	24/-	25/-
5/-	7/6	9/9	13/-	14/-	16/6	19/-	22/-	25/-	26/-	28/-	29/-

IMPORTANT TO THOSE ORDERING THROUGH SHIPPERS.—In order to ensure entire satisfaction, we advise our friends to be careful in giving definite instructions that the goods shall be procured direct from our house. By these means they may be sure of receiving the pattern and quality specified in our Catalogues.

RICHARD MELHUISH, Ltd., London, E.C.

Bronze Medal 1884—Gold Medal 1890

SUPERIOR GRINDSTONES

WOOD FRAME

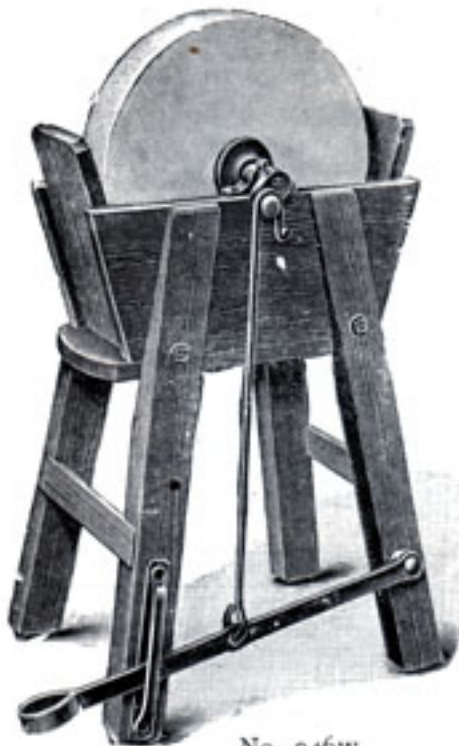

No. 946w.

IRON FRAME

No. 947w.



The Stones are best quality grit, and can be used either by farmers, engineers, carpenters, or butchers.

All the Stones are turned perfectly true on the spindle. The connecting rods, spindles, and treadles are of best Wrought Iron. Anti-friction roller bearings are recommended, making the Stone run more easily and requiring less attention and oiling.

Pulleys may be fitted to any size with plain bearings, but not to those with anti-friction rollers.

Price of Pulleys,
fast or loose, 8 in.,
12/- each; 10 in.,
16/6 each.



No. 948w.

These are similar to above, but are larger and stronger.

Size 24 x 4 in.... £6 : 8 : 0
 " 26 x 4 " ... £7 : 10 : 0
 " 30 x 5 " ... £10 : 0 : 0

For Pulleys, see above.

Size,	Wood Frame.	Wood Frame. Anti-friction Rollers.	Iron Frame.	Iron Frame. Anti-friction Rollers.
18 x 3 in. ...	£2 : 15 : 0	£3 : 2 : 6	£3 : 18 : 0	£4 : 4 : 0
18 x 4 " ...	£3 : 0 : 0	£3 : 9 : 0	£4 : 8 : 0	£4 : 14 : 0
24 x 4 " ...	£4 : 5 : 0	£4 : 13 : 0	See Pattern No. 948w.	

CHISEL AND PLANE IRON HOLDERS

No. 949w.

With this appliance plane irons, paring chisels, turning gouges, and metal scrapers may be ground rapidly and accurately, and with comfort and cleanliness.

The attachment may be fixed to the trough of No. 947w.

To suit a Stone	Price.
No. 1. 16 x 3 in. ...	45/-
" 2. 18 x 3 " ...	46/-
" 3. 20 x 3 " ...	48/6
" 4. 22 x 3½ " ...	49/-
" 5. 24 x 3½ " ...	50/-

All Carriage Forward.



RICHARD MELHUISH LIMITED, LONDON, E.C.



No. 950w.

This is of cheaper construction than our well-known "SUPERIOR" pattern. It is lighter, but quite a good general Stone. Grit is coarser.

Size of Stone in inches.	Price.
12 x 2½	47/6 each.
14 x 2½	50/- ..
16 x 3	55/- ..
18 x 3	57/6 ..
20 x 3	65/- ..
24 x 3½	86/6 ..

EXTRAS.

Fitted with Water Can and Tap. Sizes, to 20 in., 8/6; to 24 in., 10/6

All Grindstones are consigned Carriage Forward.

BENCH GRINDSTONES

No. 951w.

Best quality, fast-cutting Blue Grit Stones, fitted in iron frame with wrought iron spindles, having screwed nut and collar plates to prevent the possibility of the stone breaking.

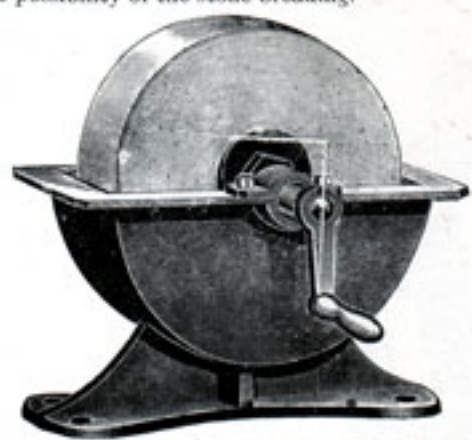

Sizes ...	8 x 1½	10 x 2	12 x 2	14 x 2½	in.
Price ...	12/6	15/-	18/6	22/6	each.

With wrought side plates and ordinary bearings.



No. 952w.

For Stone: 12x2 in., 7/6; 14 or 16x2½ or 3 in., 9/6; 18 or 20x3 in., 11/6 per set.

Japanned fittings. Complete as shown.

No. 953w.



Length of spindle:	17	21	24	in.
For Stone	15 x 2½	18 x 3	21 x 4	..
Price ...	4/6	6/6	8/6	each.

Extra strong wrought fittings with plummer blocks and brasses.

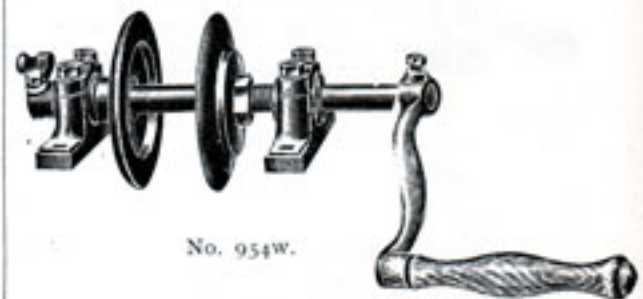

No. 954w.

For Stone	24 x 3½	30 x 4	36 x 5	in.
Price ...	30/-	45/-	58/6	per set.

PATENT GRINDSTONE DRESSERS

No. 955w.



Will true a Grindstone without dust or danger in a few minutes whilst running at ordinary speed.

Position of cutter when truing circumference of Stone.

Position of cutter when truing the edges (double-action type).

Readily fixed to troughs of varying widths by shifting brackets BB.



Tubular slide A is swivelled to bring the cutter axis into correct position relative to centre of stone. Depth of cut is regulated by the feed screw D, which draws cutter bar E in or out as required. To dress the face of the stone the saddle S is traversed along the slide A by means of the handle which actuates a screw. The cutter C, on coming into contact with the stone, revolves and removes the inequalities by a rolling wedge action and leaves the surface of the stone in perfect condition for grinding. The cutter never requires sharpening.

Size.	For Stones up to	For Troughs up to	Single Action (for face of Stone only).	Double Action (for face and edges).	Spare Cutters.
1	5 in. wide	18 in. over flanges	£6 : 5 : 0	£7 : 10 : 0	1/9 each.
2	8 ..	21	£6 : 12 : 6	£8 : 0 : 0	1/9 ..
3	10 ..	26	£8 : 5 : 0	£10 : 10 : 0	1/9 ..
4	15 ..	31	£11 : 10 : 0	£13 : 5 : 0	1/9 ..

Prices include Handle and Cutters, and one Liner for Cutters.

Builders' and Furnishing Ironmongery

TOOL AND MACHINE MERCHANTS

PATENT WOODWORKERS' VICES

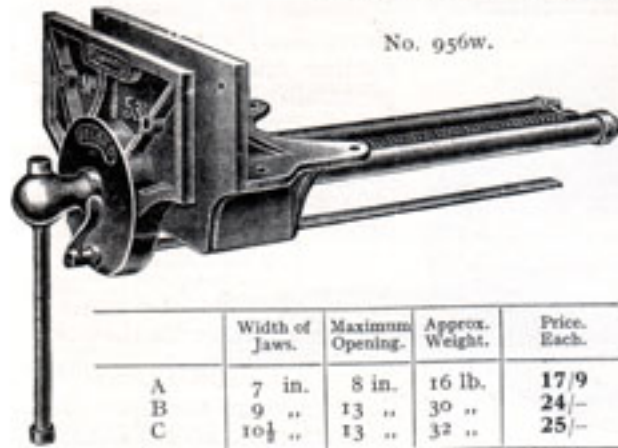

No. 956w.

	Width of Jaws.	Maximum Opening.	Approx. Weight.	Price. Each.
A	7 in.	8 in.	16 lb.	17/9
B	9 "	13 "	30 "	24/-
C	10½ "	13 "	32 "	25/-

These Vices combine all the advantages of the continuous Screw Vice with the quickness and economy of the sudden grip. They are very simple to manipulate, will give a tighter grip than any other vice, and the wearing parts are so constructed that they improve with use.

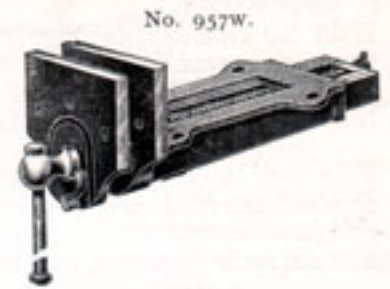

No. 957w.

	Width of Jaws.	Opening.	Weight.	Price. Each.
A	7 in.	6 in.	21 lb.	19/6
B	9 "	12 "	40 "	26/-
C	10½ "	12 "	43½ "	27/9

WOODWORKER'S VICE

Instantaneous and ordinary action.

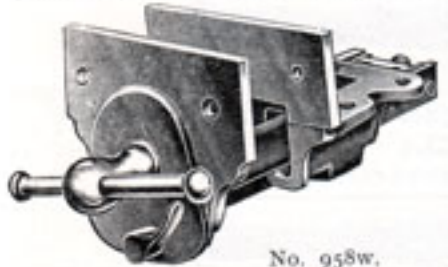

No. 958w.

No.	Width of Jaws.	Opening.	Weight.	Price.
1	7 in.	6 in.	21½ lb.	15/9
2	9 "	12 "	44 "	23/6
3	10½ "	12 "	48 "	25/6

HARDWOOD VICE

No. 959w.

Specially made for sculptors and gunsmiths. Largely in use at Bisley and other camps.

Length, 14 in.; width of jaws, 2½ in.; opening, 8 in.

Price 37/6 each.

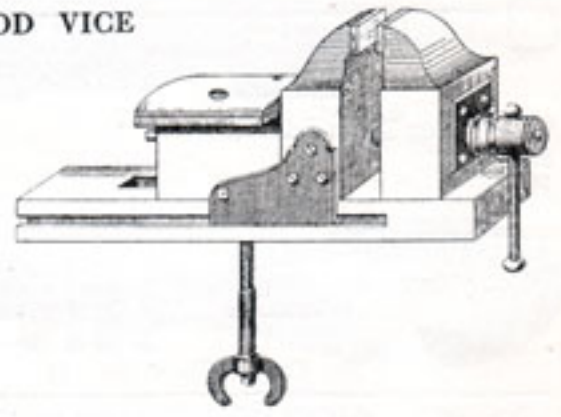

WROUGHT IRON BENCH SCREW

No. 960w.



Double thread, movable collars, wood handles.

Diameter of thread	...	1	1½	1½	in.
Price	4/6	6/-	6/6	each.

BEST MILD STEEL BENCH SCREW



No. 961w. Superior make. Malleable loose collar and undernut.

Length ...	16	18	20	in.
Diameter ...	1	1½	1½	"
Price ...	6/-	8/-	9/-	each.

No. 962w. Smaller, with fixed collar. Mild steel screw and handle, malleable collar and nut.

6 × ⅜	8 × ½	10 × ¾	in. screw.
4/-	4/3	5/-	each.

HARDWOOD BENCH SCREWS

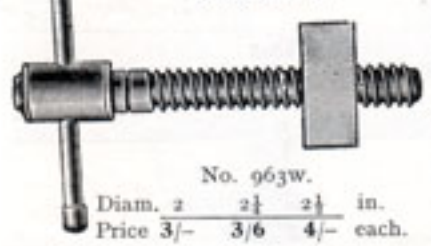

No. 963w.

Diam. 2	2½	2½	in.
Price 3/-	3/6	4/-	each.

BEST BEECHWOOD HAND SCREWS

No. 964w.

Size ...	8	10	12	14	16	18	in.
Price ...	2/-	2/3	2/9	3/3	4/6	5/6	each.

SPECIAL QUOTATIONS FOR QUANTITIES ON APPLICATION.

Goods on this page Carriage Forward.

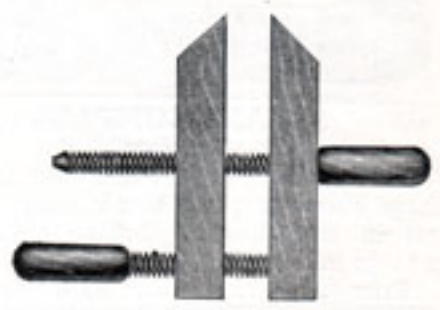

Horticultural and Estate Appliances

BEST QUALITY GLAZIERS' DIAMONDS

Suggestions and Instructions.

Hold the Diamond between the first and second finger, with the finger and thumb on the flats of the handle, as in the illustration.



Take care to find the right angle at which the cut is best obtained, and then endeavour to keep at that angle the whole length of cut.

If used too high it will "score" and the point of the Diamond will soon be worn. The correct angle will be approximately the slope on bevel of block.

Never lend your Diamond to another hand. If you do the probability is that it will be returned spoilt.

Keep the end of the cutting lath in good condition with glass-paper, and apply a little oil occasionally.

Never go over the same cut twice, not even with the thickest glass.

For rough cast and glass of that character use an old Diamond.

When the brass setting appears to be worn away, send the Diamond up to our Warehouse for examination, otherwise you may lose the stone entirely.



Crown Glass Diamonds	7/-	10/- each.	
Sheet	"	"	"	"	"	12/6	16/-	19/-	22/- "
Plate	"	"	"	"	"	—	28/6	36/-	48/- "

P.S.—We supply strong Leather Cases for our Diamonds at an extra cost of 1/- each.



For Crown Glass, 8/-, 11/- each.

For Sheet Glass, 17/-, 23/- each.

No. 967w. A very convenient and handy size for waistcoat pocket.

For Sheet Glass.

Price ... 10/-, 13/6, 17/- each.



WRITING DIAMOND No. 968w.

Used for writing on glass, bottles, lenses, etc.

Price ... 7/-, 11/- each.



FOLDING POCKET DIAMONDS

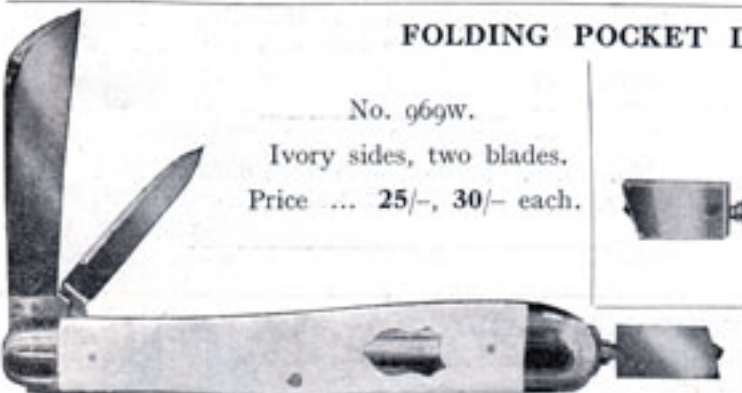

No. 969w.

Ivory sides, two blades.

Price ... 25/-, 30/- each.

No. 970w.



Buckhorn handle, with rack.

No blade.

Price ... 21/-, 24/- each.

BEAM COMPASS

No. 971w.

For cutting circles and sections from large sheets of glass, best quality diamond set in steel block. Cutting circles from 2 to 30 in. diameter.

Price ... 62/6 complete.



TOOL AND MACHINE MERCHANTS

No. 972w. STEEL WHEEL GLASS CUTTERS



SUPERIOR PATTERN Made of Brass and Nickel-plated.

Price 1/- each.
Cheaper make -/8 ..



No. 973w. GLASS TUBE CUTTER



Graduated beam. 6½ in. long ... price 5/- each.

No. 974w. TURRET HEAD CUTTER



Having six cutters price 1/6 each.

No. 975w. CIRCLE CUTTER



Cutting 2-12 in. ... price 5/- each.

MAGAZINE PATTERN No. 976w.
Containing 12 best quality wheels. Steel ball at end.
Price 2/6 each.



ALL IRON GLASS CUTTER No. 977w.
With best quality cutting wheel.
Price 1/3 each.
Cheaper pattern -/9 ..

No. 978w.
1 2 3
Price :
35/- 50/- 75/-
Cheaper quality
15/- and 20/-

DIAMOND HAND TURNING TOOL
For truing Emery Wheels. (Brazilian Carbon.)





UNIVERSAL SAFETY TOOL REST

No. 979w.

The operation of grinding by means of a fixed rest cannot be too strongly condemned. The above possesses many unique features. It is readily adjustable in width, height, and inclination. Suits all sizes of stones and troughs and secures the best possible position for grinding. It is free to swing back and instantly release hand or tool which might otherwise become jammed between Rest and stone. The Rest is shaped not only to form a support for the tool, but also for the hand, thereby promoting greater accuracy and comfort in grinding.

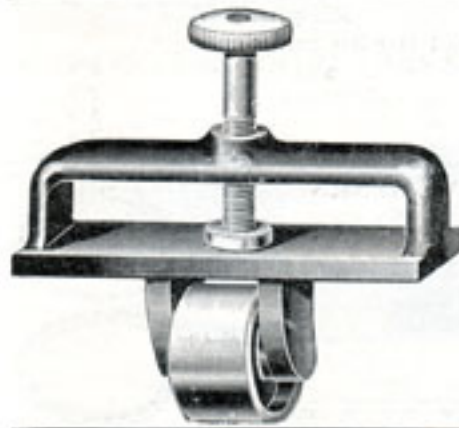
Size.	Length of Rest.	For Troughs measuring between centre of bolt holes in flanges.	Price.
1 ...	8 in.	up to 11½ in.	30/-
2 ...	10 "	" 14 "	33/6
3 ...	15 "	" 19 "	37/-
4 ...	20 "	" 23 "	40/-



TOOL GRINDING REST

No. 980w.

This is neatly made of all Malleable Iron (not brass nut as shown), and is most useful for holding chisels or plane irons whilst being ground.

Price 3/6 each.

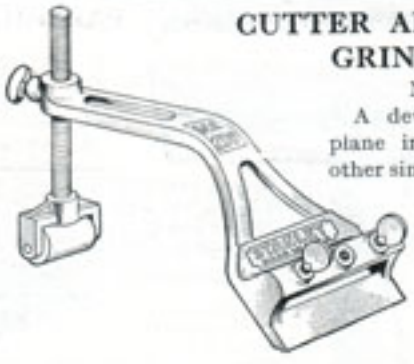

CUTTER AND CHISEL GRINDER

No. 981w.

A device for holding plane irons, chisels, and other similar cutting tools that they may be ground or honed to any desired angle or bevel.

Nickel-plated.
Price ... 6/- ea.

Bronze Medal 1884—Gold Medal 1890

GLAZIERS' AND PAINTERS' KNIVES

PUTTY KNIFE Cocoa Handle.
No. 982w.



Length of Blade ... 4 4½ 5 5½ in.
Price ... 1/3 1/4 1/5 1/6 each.

CLIPT POINT Ebony Handle.
No. 983w.



Length of Blade ... 4 4½ 5 5½ in.
Price ... 1/5 1/6 1/7 1/8 each.

CHISEL KNIFE Ebony Handle.
No. 984w.



Length of Blade ... 4 4½ 5 5½ in.
Price ... 1/4 1/5 1/6 1/8 each.

PALETTE KNIFE Cocoa Handle. Scale Tang.
No. 985w.



Length of Blade 4 5 6 7 8 9 10 12 in.
Price ... 1/1 1/3 1/6 1/11 2/- 2/9 3/6 5/- each.

HACKING KNIFE Leather Hand
No. 986w.



Length of Blade, 4½ in. Price ... 1/- each.

BENT HACKING KNIFE Strong.
No. 987w.



Length of Blade, 5 in. Price ... 1/6 each.

CHISEL KNIFE Ebony Handle.
No. 988w.



Elastic Steel, Brass Ferrule.
Width of Blade ... 2 2½ 3 4 in.
Price ... 1/9 2/- 2/3 3/3 each.

WALL SCRAPER With Hardwood Handle.
No. 989w.

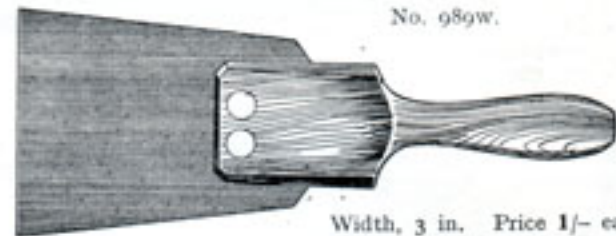

Width, 3 in. Price 1/- each.

LINOLEUM KNIFE Beech Handle.
No. 990w.



Price ... 1/9 each.
No. 990½w. In Rosewood Handle ... 2/6 ..

WALL SCRAPER Hardwood Handle. Through Tang.
No. 991w.

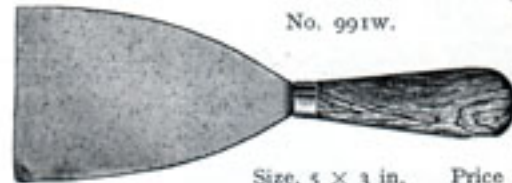

Size, 5 x 3 in. Price 1/3 each.



Size, 3½ in. wide.
A. Covered Chamois Leather.
Price 3/6 each.
B. Plain Wood.
Price 1/9 each.
With Polished Handles to unscrew.



Size, 3½ in. wide.
C. Covered India-rubber.
Price 3/3 each.
D. Seam Roller, 1½ in. wide, Boxwood.
Price 2/3 each.

PAPERHANGERS' ROLLERS

No. 992w.

Size, 7 in. With Polished Handles to unscrew.

E. Covered Chamois Leather. Price ... 4/9 each.
F. Plain Wood. 2/3 ..
G. Covered India-rubber. 4/3 ..
H. Angle Roller, 1½ in. wide, Boxwood. 2/6 ..

PAPERHANGERS' SHEARS

Best English Manufacture. No. 993w.



Length ... 8 9 10 11 12 in.
Price ... 3/9 4/- 4/9 5/9 7/- each.

TOOL AND MACHINE MERCHANTS

PATENT WALLPAPER TRIMMER



No. 994W.

It unwinds the paper, trims one or both edges "fine," or one "fine" and one "rough," and re-winds the piece at one operation in 40 seconds (90 pieces per hour). To trim the paper of a nine-piece room costs you (with scissors) 2/-, with Trimmer, -/2. Trims the edges of plain papers perfectly true for "butt" joints. Makes scissors an out-of-date tool.

We can supply numerous testimonials on request, but the best one is the fact that over 20,000 of these Trimmers are in regular use in the United Kingdom. The cutters are self-sharpening as they work.

To cut all widths to 22 in., £7 : 5 : 0; to cut 30 in., £8 : 10 : 0

An attachment is supplied for trimming relief decorations, as lincrusta, at an extra cost of 26/3. When ordering, kindly state which Machine it is for.

No. 995W.

THE IDEAL PAINT REMOVING AND SOLDERING LAMP



It burns off paint perfectly and solders small joints equally well. The Lamp burns in any position and gives a strong fine jet. Spirit used is Methylated. Price 5/- each. Soldering Iron, 1/6 extra if required. For larger and more powerful Lamps, see our Engineers' Catalogue.



PAINT REMOVING LAMP

For Paraffin, with Round or Flat Nozzle.

No. 996W. With Round Nozzle.
Price 15/- each.
No. 997W. With Flat Nozzle.
Capacity, 1 pt.
Price 17/6 each.

PAPERHANGER'S ROLLER No. 998W.



Combined Angle and Seam Roller. In Boxwood.
Price 2/9 each.

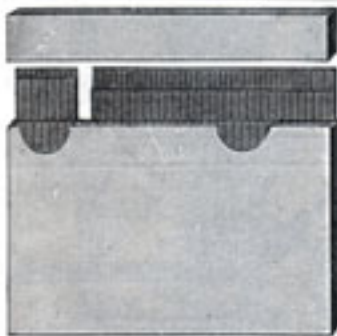

GRAINING COMBS

No. 999W.
Price 4/6
per set of
12 in
Tin Case.

Loose Combs,
-/2½ per in.

No. 1000W.

Size.	Price.
1 in. ...	4/-
1½ " ...	5/6
1¾ " ...	7/6
2 " ...	11/-
2½ " ...	16/6
3 " ...	20/-

BRASS FOLLOWER

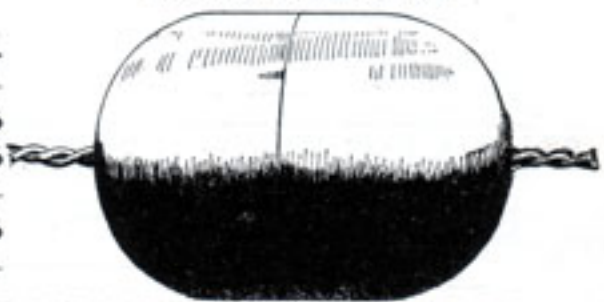

PAINTERS' WIRE BRUSHES

No. 1001W.



Price in 4 rows, Fine or Medium Wire ... 1/3 each.

IMPROVED PATTERN LEAD AND ZINC CUTTER

No. 1002W.



Price 2/6 each.

This Section of our Catalogue contains the leading lines in Woodworkers', Painters', and Plumbers' Tools, Machines, and Accessories. Other sections, embracing a great variety of Engineers' Tools, Machines, and Appliances, Electrical Goods, Motor Tools, Horticultural and Estate Agents' Requirements, Builders' and Furnishing Ironmongery, Wireless, Sanitary Fittings, etc., will be sent per post on application.

Builders' and Furnishing Ironmongery

PLUMBERS' TOOLS

BENDING IN STICKS No. 1003w.



Price ... Small. 2/3 Medium. 2/6 Large. 3/- each.



HANDLED STEP TURNER

No. 1004w.



Price ... 3/3 each.

DOUBLE-ENDED SETTING IN STICK
No. 1005w.



Price ... 3/6 each.

SETTING IN STICK No. 1006w.



Price ... Small. 2/3 Medium. 2/6 Large. 3/- each.

STEP TURNER
No. 1007w.



Price ... 2/9 each.

DRESSER

No. 1008w.

Small. Medium. Large.

Hornbeam 2/- 2/3 2/6 ea.
Boxwood 2/6 3/- 4/- ..



MANDRILS No. 1009w.



Size ... 1 1 1/2 1 3/4 in.
Price ... -/9 1/- 1/3 each.
Size ... 2 2 1/2 3 in.
Price ... 2/- 3/- 5/6 each.

CANE HANDLED MALLETS



No. 1010w.
Size ... 2 2 1/2 2 3/4 3 in.
Price ... 1/3 1/4 1/6 2/2 ea.

BOSSING MALLETS

No. 1011w.

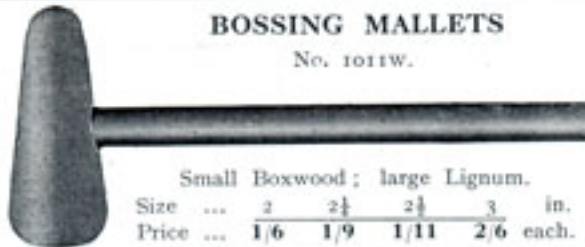

Small Boxwood; large Lignum.
Size ... 2 2 1/2 2 3/4 3 in.
Price ... 1/6 1/9 1/11 2/6 each.

BOBBINS

No. 1012w.



Same prices as Turnpins.

IRON BOUND Mallet No. 1013w.



Lignum Vitae, with Ash Handle.
Size ... 2 1/2 3 4 in.
Price ... 3/9 4/9 6/6 each.

STEEL DRIP PLATE



No. 1014w
Price ... 2/2 each.

TURNPINS No. 1015w.



Size 1 1 1/2 1 3/4 2 2 1/2 3 3 1/2 4 in.
Price -/3 -/4 -/5 -/7 -/10 1/6 2/- 2/9 ea.

BILLINGS PATTERN PIPE BENDER No. 1016w.



Size ... 1 1 1/2 1 3/4 2 in.
Price ... 5/9 4/9 6/- 8/- each.

MALACCA CANE HANDLED DUMMY No. 1017w. Assorted lengths.



Price ... 5/- each.

STEEL BEND BOLTS No. 1018w.

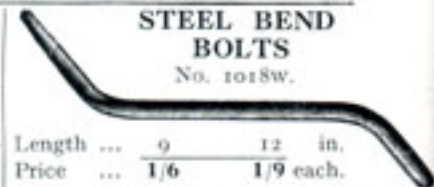

Length ... 9 12 in.
Price ... 1/6 1/9 each.

WIPING CLOTHS No. 1019w.



Size ... 3x3 4x3 4 1/2 x 4 in.
Price ... 1/4 1/4 2/- each.

CHASE WEDGE No. 1020w.



Size ... 2 2 1/2 3 in.
Price ... 1/1 1/6 1/9 each.

COPPER SOIL POTS No. 1022w.



Price 2/3 each.

BOSSING STICK No. 1021w.



Small. 2/3 Medium. 2/6 Large. 2/9 each.

SCRIBING PLATES No. 1023w.

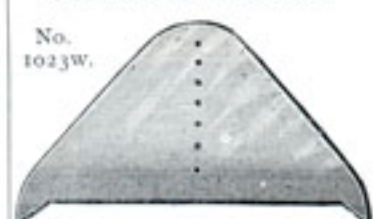

Size ... 4 1/2 6 1/2 in.
Price ... 2/6 3/- each.

If you cannot find what you require in this List, please write to us.

TOOL AND MACHINE MERCHANTS

PLUMBERS' TOOLS

TRIANGULAR SHAVE HOOK
No. 1024w.



Price ... 1/- each.

HEART SHAPE HOOK
No. 1025w.



Price... 1/- each.

COMBINATION PATTERN
No. 1026w. As shown.



Price ... 1/6 each.

WROUGHT IRON LADLES
No. 1027w.



Size ...	2	3	3½	4	5	6	in.
Price ...	1/-	1/1	1/3	1/6	2/-	3/-	each.

MELTING POTS
No. 1028w.

With Improved Pattern Upright Ears.



Capacity	1	1½	2½	4	6	8	pt.
Size	4	5	6	7	8	9	in.
Price	2/3	2/6	3/6	4/3	4/9	5/6	ea.

STRONG PAINT CANS
No. 1029w.
Galvanised.



Size ...	5	6	7	8	in.
Price ...	9	1/-	1/3	1/6	ea.

PAINT OR DISTEMPER STRAINERS
No. 1030w.
With Removable Gauzes.



Size ...	4	5	6	in. diam. gauze.
Price ...	1/9	3/-	4/-	each.
Spare gauzes	1/-	1/1	1/2	..

MILLS FOR GRINDING PAINT, ETC.

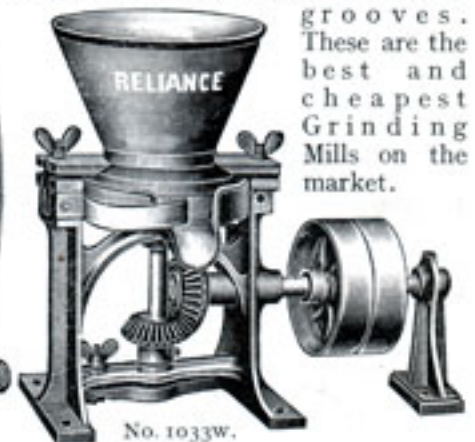

The efficiency and output of these Grinding Mills have been increased 50 per cent. by making them with bright polished iron grinding surface with cut grooves both in cone and hopper, instead of cast cones and grooves. These are the best and cheapest Grinding Mills on the market.

Prices in japanned green; hopper and channel enamelled white inside:

"RELIANCE" PAINT MILL.				Height.	Diameter of Grinding Cone.	Diameter of Hopper (inside).	Capacity of Hopper.	Weight.	Grinding Capacity per hour.	Price.
No. 1031w, with Handle.	Size 1	12½ in.	4½ in.	6 in.	2 pt.	16 lb.	6½ lb.	46/- each.
	" 2	15 ..	5½ ..	7½ ..	4½ ..	29½ ..	11 ..	58/- ..
	" 3	17 ..	6½ ..	8½ ..	6½ ..	41 ..	17 ..	73/- ..
No. 1032w, with Flywheel.	" 2	15 ..	5½ ..	7½ ..	4½ ..	30½ ..	11 ..	70/- ..
	" 3	17 ..	6½ ..	8½ ..	6½ ..	61 ..	17½ ..	88/- ..
	" 4	19 ..	7½ ..	9 ..	9 ..	80½ ..	23 ..	110/- ..
No. 1033w, with Pulley.	" 4	19 ..	7½ ..	9 ..	8 ..	60 ..	44 ..	118/- ..
	" 5	24 ..	10 ..	11½ ..	13½ ..	141 ..	88 ..	172/- ..

Electric and Wireless Engineers

RICHARD MELHUIH LIMITED, LONDON, E.C.

POKER WORK AND RELIEF BURNING, Etc.



No. 1034W.

The "Amateur" is an efficient but inexpensive apparatus. Can be fitted with any Platinum Point—see below.
 Price, without Point 15/-

When ordering Poker Machines, please state pattern or number of Platinum Point required.

No. 217W.
GUIDE TO POKER WORK
 By W. D. THOMPSON.
 Sixth Edition.
 This is the most practical and up-to-date Guide to Poker Work yet published. Price 1/2



No. 1035W.

The "Pyro" is a very handy Machine, with an exceedingly simple flame or burner top. The flame top, which takes the place of the Spirit Lamp in the "Original" Machine, is worked exactly like a gas jet, and burns entirely without smell. The "Pyro" Machine is cheaper than the "Simplex" on account of the simplicity of the flame top.

Can be fitted with any Platinum Point—see below.
 Price, without Point 16/-



No. 1036W. Price 19/6 each.



No. 1037W. Price 28/6 each.



No. 1038W. Price 27/6 each.



No. 1039W. Price 25/- each.



No. 1040W. Price 29/6 each.



No. 1041W. Shading Point. Price 28/6 each.

LEATHER WORKERS' TOOLS

No. 1042W.

A. Hammer	2/6 each.
B. Dresden Tool	1/6 "
C. Point	1/6 "
D. "	1/6 "
E. Knife	1/6 "
F. Small Modelling Tool	1/9 "
G. Large "	2/- "
H. Wheel	2/- "
I. Ring Punch	1/- "
J. Matting Tool	1/6 "
K. Square Nail Head Punch	1/3 "
L. Oval "	1/3 "
M. Steel Rule; length, 12 in.	1/3 "
N. Brass Rule	1/- "

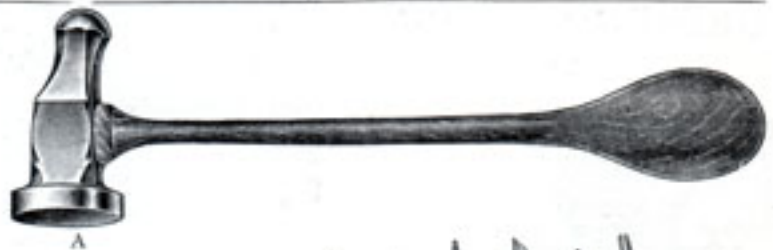

LEATHER SHEARS WITH TOOTHED BLADE

No. 1043W.



These Shears are made specially for cutting leather. The lower blade is notched as shown, and prevents any slipping of the material. The upper blade is very thin and sharp, and care must be exercised to avoid such articles as copper rivets or lacing in belting.

Length, 8 1/2 in. Price 5/6

Bronze Medal 1884—Gold Medal 1890

TOOL AND MACHINE MERCHANTS

MASONS' TOOLS

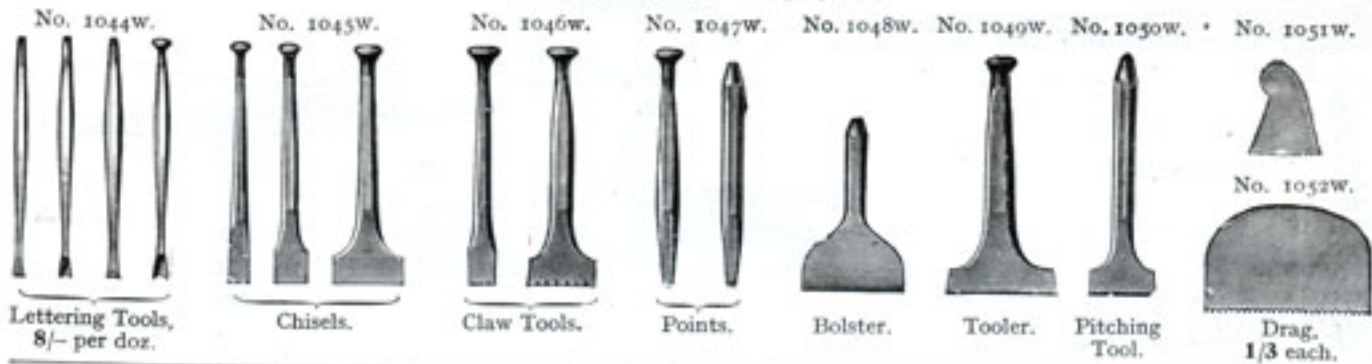

No. 1045w. Mallet Head Chisels,	1/2	3/4	1	1 1/4	1 1/2	1 3/4	2	2 1/2	3 in.	No. 1047w. Points, 1/2-1 in., 1/- each.
.. 1046w. Claw Tools	-/10	-/10	1/-	1/-	1/2	1/3	1/4	1/5	1/7	.. 1048w. Bolster, 4 in., 2/2 each.
.. 1050w. Pitching Tools	-	-	-	-	1/3	-	1/4	-	1/7	.. 1051w. Combs, asstd., 1/1 each.
					1/4	1/6	1/6	1/8	1/10	.. 1049w. Tooler, 3 1/2-5 in., 2/3-3/- ea.

No. 1053w.

BEST CAST STEEL BRICK TROWELS

Size ...	10	11	12	13	in.
Price ...	3/6	3/8	3/10	4/3	each.

No. 1054w.

CAST STEEL POINTING TROWEL

Size ...	5	5 1/2	6	7	8	in.
Price ...	1/6	1/8	1/9	2/-	2/3	each.

No. 1055w.

CAST STEEL GAUGING TROWELS

Size ...	5	6	7	in.
Price ...	2/4	2/6	2/8	each.
Size ...	8	9	in.	
Price ...	2/10	3/3	each.	

No. 1056w.

TWITCHER OR ANGLE TROWEL

Width ...	2	2 1/2	2 3/4	3	in.
Price ...	4/-	4/3	4/6	4/9	each.

W.H.S. CELEBRATED TROWELS

No. 1057w.

Size ...	12	12 1/2	13	in.
Price ...	4/11	5/1	5/3	each.

No. 1058w.

Single Hang

Length, 11 in., price ... 7/6 each.

HY. DISSTON'S PLASTERING TROWELS

The mounting and handle of this Trowel are adjusted by an improved method, making it strong, durable, and easy to the hand. The blade is of the very best quality Steel, highly tempered, and ground tapering from the centre to the edges on the working side.

No. 1060w. Finishing Trowel, 9/3

No. 1059w.

Double Hang

Length, 11 in., price ... 8/6 each.

No. 1061w.

BEST QUALITY ENGLISH PLASTERING TROWELS

Size, 11 in.

Single Hang, price ... 5/6 each.

Double 6/6 ..

BEST QUALITY ENGLISH PLASTERING TROWELS

Size, 11 in.

Single Hang, price ... 5/6 each.

Double 6/6 ..

No. 1062w.

BEST QUALITY ENGLISH PLASTERING TROWELS

Size, 11 in.

Single Hang, price ... 5/6 each.

Double 6/6 ..

No. 1063w.

FLOORING TROWEL

For Cementers.

Length ...	12	13	14	in.
Price ...	6/6	7/-	7/6	each.

FLOORING TROWEL

For Cementers.

Length ...	12	13	14	in.
Price ...	6/6	7/-	7/6	each.

BRICKLAYERS' JOINTERS

No. 1064w.

Width on Face	1/2	3/4	1 in.
Short, 2 1/2 in.	1/6	1/6	1/6 ea.
Long, 5 in.	2/-	2/-	2/- ..

RICHARD MELHUISH LIMITED, LONDON, E.C.



SLATER'S RIPPER

No. 1065w.
Length, 30 in.

Price 5/6 each

BRICKLAYER'S HAMMER
No. 1066w.

Handled.
Weight, 2 lb.
Price ... 3/3 each

SLATER'S AXE
No. 1067w.

Price 6/6 each.

MORTAR PICK
No. 1068w.
Price 3/9 ea.

SLATER'S DRESSING IRON
No. 1069w.
Length, 10 in.
Price 2/- each.

MASON'S SOLID STEEL HAMMER
No. 1070w.
Weight 2 2½ 3 lb.
Price ... 2/- 2/6 2/9 ea.

LATH HAMMER No 1071w.
No. ... 1 2 3
Price ... 3/3 3/6 3/9 each.

SOLID HEAD BRICK SCUTCH
No. 1072w.
Handle and Wedge 4/9
Blade only ... 2/6

SLATER'S AXE, WITH CLAW
No. 1073w.
Best Quality.
No. ... 1 2
Price ... 5/3 5/9 each.

BRICKLAYERS' IMPROVED SCUTCHES
No. 1074w.
Price 6/6 each.

Extra Blade, 1/9

JOINT RULES No. 1075w.
Length 2 3 4 6 8 10 12 14 in.
Price -/6 -/8 -/8½ 1/2 1/5 1/9 2/1 2/4 ea.

SCAFFOLDING HAMMER No. 1076w.
London Pattern.
Handled.
Weight 2 2½ 3 lb.
Price 5/6 6/6 7/- each.

HANDLED BRICK CLEANER
No. 1077w.
Price ... 4/- each.

IRON SQUARE
No. 1078w.
18 x 12 x 1½ in. ... 2/6 each.
24 x 12 x 1½ .. 3/- ..

MORTAR LARRIE
No. 1079w.
Length, 10 in.
Price 3/- ea.
Handle extra.

Builders' and Furnishing Ironmongery

TOOL AND MACHINE MERCHANTS

SADDLERS' TOOLS

EDGE SHAVE No. 1080w.



Price 2/- each.

SCREW CREASE No. 1081w.



Price 2/6 each.

BEVEL CREASE No. 1082w.



Price 1/9 each.

SINGLE CREASE No. 1083w.



Price 1/3 each.

HAND WHEEL AND FRAME No. 1084w.



Price 8/6 each.

BENT PALM No. 1085w.



Price 1/6 each.

CUTTING KNIFE

5 in. 4/-
6 " 5/-
7 " 6/-

No. 1086w.



PLOUGH GAUGE

No. 1087w.

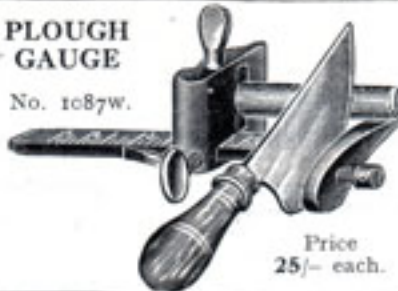

Price 25/- each.

SET OF LEATHER PUNCHES

No. 1088w.
Twelve sizes,
1/8 to 1/2 in.



Price, complete in nice neat box, 17/6

SOLID STEEL SADDLER'S PUNCH No. 1090w.



Nos. ...	1 to 6	7	8	9	10	11	12	13	14	16
Sizes ...	1/8 to 3/8	7/8	1	1 1/8	1 1/4	1 1/2	1 3/4	1 7/8	2	2 1/2 in.
Price ...	-5 1/2	-6	-7	-8	-10	1/-	1/1	1/3	1/4	1/9 ea.

WAD OR LEATHER PUNCH

No. 1091w.



Size ...	1/8	3/8	1/2	5/8	3/4	7/8	1 in.
Price	1/10	1/10	1/11	2/-	2/-	3/9	5/- each.
Size ...	1 1/2	1 3/4	1 7/8	2	2 1/4	2 1/2	2 in.
Price ...	6/6	8/3	10/-	12/6	15/6	19/-	each.

Prices of larger sizes on application.

EYELET CLOSING PLIERS No. 1092w.



Length ...	7	7 1/2	8 in.
No. ...	0	1	2
Price ...	3/3	3/6	3/9 each.

PUNCH PLIERS No. 1093w.



Length, 6 1/2 in. ...	price 2/9 each.
Extra nipples ...	-6 ..

HAND PUNCH

No. 1094w.

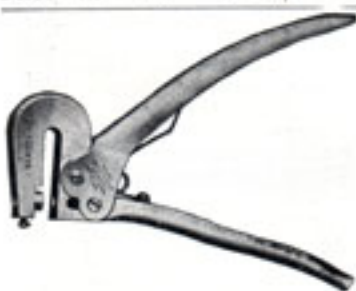

This will punch without burr through 1/8 in. sheet brass, steel, iron, and metal of every description to 17 gauge in diameter, also slate without cracking. In softer materials to 1/2 in. thick. The tool is made of forged steel, and all parts are interchangeable. Depth of throat, 1 1/2 in.

Price, with one 1/2 in. punch 11/6 each.

The set of six punches, 1/8 to 1/2 in., and dies to fit punch ... 13/- ..

Single Punch and Die, price 2/3 ..



Horticultural and Estate Appliances

SHOEMAKERS' TOOLS



SHOE KNIVES

No. 1095w
Beech handled. Length of blade, 4 in.
Price 1/- each; 10/6 per doz.

BROAD POINT KNIVES

No. 1096w.
Beech Handles. Length of blade, 4 in.
Price 1/- each; 10/6 per doz.



SHOE PINCERS



No. 1097w.
London Pattern. Length, 7 in. Price 4/- each.

BULL-DOG PINCERS



No. 1098w.
Price 4/6 each.



No. 1099w.
Length, 6 in., 3/- each; 7 in., 3/6 each.

END CUTTING NIPPERS



No. 1100w.
Length, 7 in. Price complete, 3/-; extra Punch, -/6 each.

PUNCH PLIERS



SHOEMAKER'S TOOL CHEST

- No. 1101w.
- | | |
|----------------------------|-------------------------------------|
| 1 Shoe Rasp imp. 1/4 file. | 1 Shoe Pincer B.A. x 2. |
| 1 London Hammer No. 2. | 1 Shoe Pincer B.A. x 0. |
| 1 Tower Nipper No. 0. | 1 Rhan File. |
| 1 Peg Haft No. 2. | 1 Double Iron No. 3 x D. |
| 1 gro. Tacks Asstd. | 1 Movable Peg Wheel. |
| 1 Sand Stone. | 3 O.S. Pegging Awl Hafts. |
| 1 Punch Plier 8. | 1 Drag Knife No. 1. |
| 1 Peg Knife No. 20. | 1 Cutting Nipper No. 1. |
| 1 Short Peg Tool No. 6. | 1 Fudge Wheel No. 30 x 10. |
| 1 Shoe Knife No. 402 C. | 1 Shoe Scraper. |
| 1 Eyelet Plier No. 2. | 1 Waist Wheel. |
| 1 Forepart Iron No. 1 x D. | 12 Shouldered Oval Peg Awls, Asstd. |
| 1 Glazing Iron No. 14 x 2. | |
| 3 Beech Awl Hafts. | |
| 6 Sewing Awl, Asstd. | |
- Price complete, as above 60/-
No. 1102w. With 28 Tools 45/-
No. 1102 1/2 w. With 11 Tools 18/-

SINGLE WASHER CUTTER

Best Wrought.
No. 1103w.
Will cut washers up to 1oin. diam.
Price 6/- each.



DOUBLE WASHER CUTTER

Best Wrought.
No. 1104w.

Will cut washers up to 1oin. diam.

Price 8/-



NEW PATTERN CUTTER

Best English Manufacture.

No. 1105w.

No. 1. Cutting to 6 in. diam. circle, 4/6 each.
No. 2. Cutting to 11 in. diam. circle, 6/6 each.



TOOL AND MACHINE MERCHANTS

REPOUSSE TOOLS

No. 1106w. Tracing Tools.



-/8 each.

No. 1107w.
Solid Brass.



Raising Tools.



Price -/6 each up to No. 17; No. 18, -/9 each.

STEEL RAISING TOOLS

No. 1108w.



All sizes from 19 to 40 inclusive, -/9 each.

No. 1109w.

RING TOOL AND PEARLS



-/9 each.

1/- each.

-/9 each.

1/- each.

No. 1110w.

MATTING OR GROUNDING TOOLS



Nos. 61 to 77, -/10 each; Punches No. 78 as illustrated, 1/- each.

ALL METAL CENTRIFUGAL DRILL BRACE WITH CHUCK

No. 1111w.



First-class manufacture and finish. Nickel-plated. Total length, 14 in.

Price 5/6 each.

ALL METAL NICKEL-PLATED CENTRIFUGAL DRILL

No. 1112w.



Length, 10 in. overall.

Price, with 6 Drills 3/3 each.

PISTOL GRIP HAND DRILL

No. 1113w.

This Drill has been specially designed to provide the discriminating mechanic with an entirely satisfactory Tool for all classes of drilling, reaming, and wood boring by hand. Machine-cut gears. Ball thrust. Worm gear drive. Capacity, 1/8 in.

Price 12/6 each.



Bronze Medal 1884—Gold Medal 1890

RICHARD MELHUISE LIMITED, LONDON, E.C.

EGG-EYED UPHOLSTERERS' AND MATTRESS NEEDLES



UPHOLSTERER'S NEEDLE



MATTRESS NEEDLE

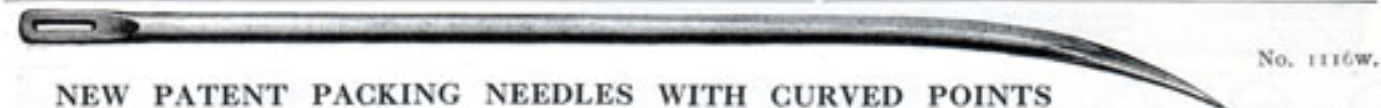

NEW PATENT PACKING NEEDLES WITH CURVED POINTS

Length... ..	5	6	7	8	9	10	12	14 in.
No. 1114W. { per doz.	1/3	1/6	1/9	2/-	2/2	2/4	2/9	3/3
{ each.	-1 1/2	-2	-2	-2 1/2	-2 1/2	-2 1/2	-3	-4
" 1115W. { per doz.	1/3	1/6	1/8	1/9	2/-	2/3	3/-	3/3
{ each.	-1 1/2	-2	-2	-2	-2 1/2	-2 1/2	-3 1/2	-4
" 1116W. { per doz.	1/-	1/3	2/-	2/6	3/-	4/6	—	—
{ each.	-1 1/2	-1 1/2	-2 1/2	-3	-4	-5	—	—

ROPING NEEDLE (Sail) No. 1117W.



SEAMING NEEDLE (Sail) No. 1118W.



NEW PATTERN No. 1119W.
For general purposes.

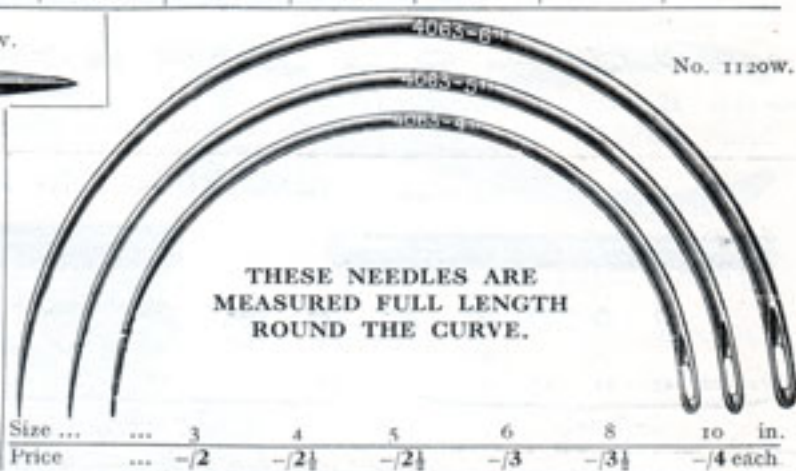
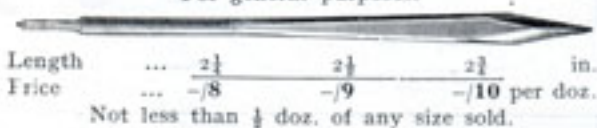

CARPET STRETCHERS No. 1121W.



UPHOLSTERERS' PINCERS No. 1122W.



UPHOLSTERERS' HAMMERS

No. 1123W.

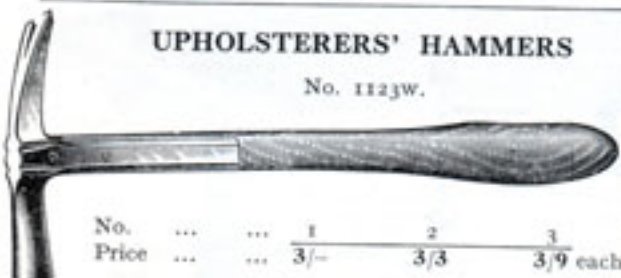

No. 1124W.

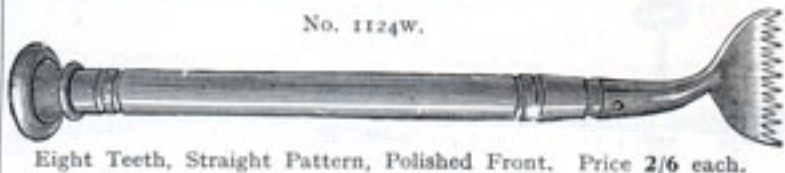

CABRIOLET HAMMER

No. 1125W.



CANVAS STRETCHER

No. 1126W.



CHAIN BURNISHERS

Double.
No. 1127W.

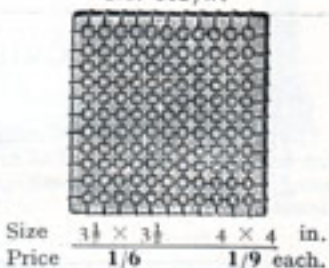

TOOL AND MACHINE MERCHANTS



NEW WORKMAN'S BAG

No. 1128W.

Everlasting wear. The fabric is spun and woven very closely, and is not affected by rain or hard wear.

Size across $\frac{30}{5/6}$ $\frac{33}{6/-}$ $\frac{36}{6/3}$ in.
Price ...

CARPENTERS' TOOL BASKETS

No. 1129W.

Rush, lined with Stout Sailcloth, and Bound.

No. ...	2	3	4	5	6
Size, approx.	27	30	33	36	39
Price	$\frac{2}{3}$	$\frac{2}{6}$	$\frac{3}{-}$	$\frac{3}{6}$	$\frac{4}{3}$ each.



BROWN CANVAS HARDWEAR BASKETS

No. 1130W

No. ...	2	3	4	5	6
Size, approx.	25	29	31	34	36
Price	$\frac{3}{6}$	$\frac{4}{-}$	$\frac{4}{6}$	$\frac{5}{3}$	$\frac{6}{-}$ each.

BEST TOWER PINNERS

No. 1132W.



Length ... $\frac{6}{1/4}$ $\frac{7}{1/6}$ $\frac{8}{2/-}$ in.
Price ...

BEST LANCASHIRE PINNERS

No. 1133W.



Length ... $\frac{6}{2/9}$ $\frac{7}{3/3}$ $\frac{8}{3/9}$ $\frac{9}{4/6}$ in.
Price ...

BLACK WING COMPASSES

No. 1134W.



Length ... $\frac{6}{3/-}$ $\frac{7}{3/3}$ $\frac{8}{3/6}$ $\frac{9}{4/3}$ $\frac{10}{4/6}$ in.
Price ...

SILL BORER OR JOIST TOOL

No. 1131W.

(Ball Bearings.)

This is indispensable to car builders, electricians, etc., for boring at right angles. Depth of head is only $2\frac{1}{2}$ in., permitting its use in narrow spaces.

Length, 23 in. Price ... $\frac{28}{-}$ each.

Japanned frame, working parts hardened Steel; sweep, 12 in.

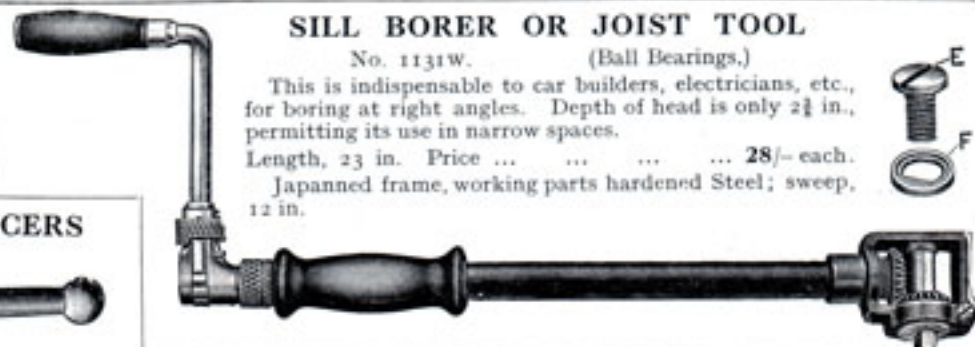

RATCHET

AUGER HANDLE

No. 1135W.

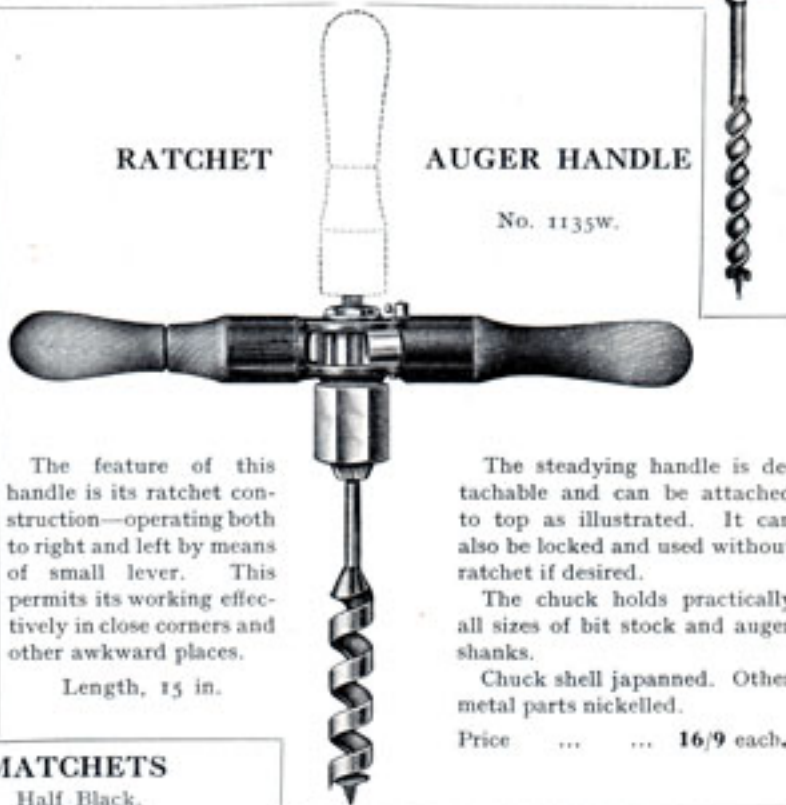

The feature of this handle is its ratchet construction—operating both to right and left by means of small lever. This permits its working effectively in close corners and other awkward places.

Length, 15 in.

The steadying handle is detachable and can be attached to top as illustrated. It can also be locked and used without ratchet if desired.

The chuck holds practically all sizes of bit stock and auger shanks.

Chuck shell japanned. Other metal parts nickelled.

Price ... $\frac{16}{9}$ each.

MATCHETS

Half Black.

No. 1136W.



Length ... $\frac{14}{15/-}$ $\frac{16}{13/6}$ $\frac{18}{14/-}$ $\frac{20}{14/6}$ $\frac{22}{15/-}$ in.
Price (either pattern) ... per doz.

Packing Cases extra.

These are not for Home Trade, but are used extensively in the Colonies and elsewhere in sugar plantations, etc.

No. 1137W.

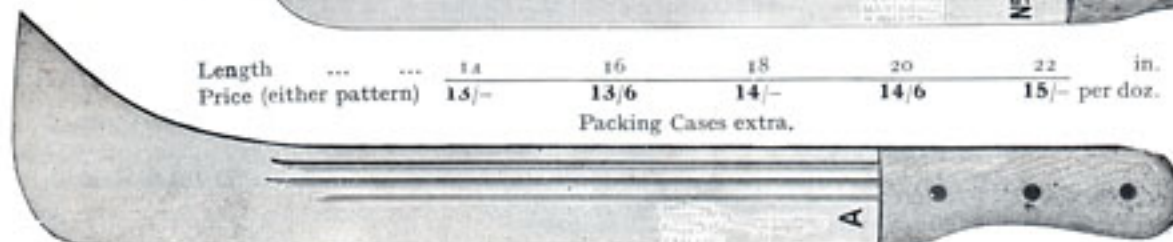

Builders' and Furnishing Ironmongery

SUNDRY TOOLS

RAILWAY CARRIAGE KEY
No. 1138W.
Price 1/6 each.



BOXWOOD LATHE CHUCKS No. 1139W.
Size ... 1 1/2 2 2 1/2 3 4 in.
Price ... 1/- 1/3 1/6 1/9 2/- each.



PLASTERERS' SMALL TOOLS
No. 1140W.
Assorted Patterns. 1/4 in. wide.
Price 2/- each: 23/- per doz.



CARD WIRE No. 1141W.
For cleaning Files.
1 1/2 in. wide. Price -/5 per ft.



FILE HANDLES
No. 1142W.
With screw for warding and other small files. Price 1/- each.



GRADUATED TYRE WHEEL
No. 1143W.
The circumference of wheel is exactly 2 ft. graduated by 1/8th of an in. The pointer is held in place by friction and can be set instantly.
Price 10/- each.



CANVAS HANDBAG
No. 1144W.
For keeping a few tools in. Very strong and most useful. Length, 14 in. Price 8/6 each.



CLOSING PLIERS
No. 1145W.
For Bent Iron Work.
Price 3/6 each.



YANKEE TOOL SET No. 1146W.
Consisting of a Spiral and 2 Ratchet Screwdrivers, Chuck with 8 drills, 1/8 to 1 1/2 in., and a Countersink. Price 35/- ea.



PATENT CHISEL HANDLES
No. 1147W.
Manufactured from solid Beech and bound with metal band. They are unbreakable.
Size across ferrule 1/2 3/4 1 1 in.
Price ... -/5 -/5 1/2 -/6 -/7 each.



EXPANSION DRILL
No. 1148W.
For cutting holes in metal. Invaluable to the plumber for tank work.
Price, with round shank, as illustrated, or with square for fitting an ordinary brace, 6/- each.
Extra cutter, 1/6 each.



BOXWOOD DESK RULE No. 1149W.
Length, 18 in. Bevelled Edge. Price 1/3 each.
Ditto, Brass Tipped. Price 1/6 each.



ASSORTED FRET FILES ON CARD No. 1150W.
Length, 5 1/2 in. Price 1/3 per card.



PIANO KEYS No. 1151W.
With Hardwood Handle. Price 2/3 each.
No. 1152W. T shape. Price 2/- each.



PLUMBER'S OR ELECTRICIAN'S CHISEL No. 1153W.
Specially adapted for lifting floorboards without injury.
Width of cutting edge, 2 in. Price 2/- each.



Horticultural and Estate Appliances

TOOL AND MACHINE MERCHANTS

WALL PLUGS AND PLUGGING CHISELS

INVALUABLE TO ELECTRICIANS, GAS FITTERS, DECORATORS, AND BUILDERS

STAR SECTION SOLID STEEL WALL DRILLS



No. 1154W.

Size $10 \times \frac{1}{8}$ $12 \times \frac{1}{8}$ $10 \times \frac{1}{4}$ $12 \times \frac{1}{4}$ $10 \times \frac{3}{8}$ $12 \times \frac{3}{8}$ in.
Price $\frac{-}{10}$ $1\frac{-}{-}$ $1\frac{-}{-}$ $1\frac{2}{2}$ $1\frac{2}{2}$ $1\frac{6}{6}$ each.

OCTAGON STEEL CHISELS FOR BRICKS

Length	12	18	24	in.
in. diam.	$\frac{1}{6}$	$\frac{2}{-}$	$\frac{2}{6}$	each.
..	$\frac{1}{8}$	$\frac{2}{2}$	$\frac{3}{-}$..



No. 1155W.

CORRUGATED IRON CHISEL No. 1156W.



Size $8 \times \frac{1}{4}$ in. Price $1\frac{3}{3}$ each.

CAST STEEL WALL DRILL No. 1157W.



Size $10 \times \frac{1}{8}$ $10 \times \frac{1}{4}$ $10 \times \frac{3}{8}$ $10 \times \frac{1}{2}$ in.
Price $\frac{1}{1}$ $\frac{1}{3}$ $\frac{1}{6}$ $\frac{1}{9}$ each.

PUNCH FOR CORRUGATED IRON No. 1158W.



Size $7 \times \frac{1}{4}$ in. Price $\frac{-}{10}$ each.

PLUGGING CHISEL No. 1159W.



Size $10 \times \frac{1}{4}$ in. Price $1\frac{6}{6}$ each.

LIGHTNING PLUGGING CHISEL No. 1160W.



Size	$\frac{1}{2} \times 9$	$\frac{3}{4} \times 9$	$\frac{1}{2} \times 10$	$\frac{3}{4} \times 10$	$\frac{1}{2} \times 12$	1×12 in.
Price	$\frac{1}{3}$	$\frac{1}{4}$	$\frac{1}{9}$	$\frac{2}{-}$	$\frac{2}{6}$	$\frac{3}{-}$ each.

LIGHTNING WALL PLUGS No. 1161W.

Size	$\frac{1}{2}$	$\frac{3}{4}$	$\frac{1}{2}$	$\frac{3}{4}$	1	in.
Price	$\frac{4}{-}$	$\frac{4}{-}$	$\frac{4}{6}$	$\frac{5}{-}$	$\frac{5}{6}$	$\frac{6}{-}$ per 100.
..	$\frac{-}{8}$	$\frac{-}{8}$	$\frac{-}{8}$	$\frac{-}{9}$	$\frac{-}{10}$	$\frac{1}{-}$.. doz.



RAWLPLUG OUTFITS No. 1162W.

The Domestic Set, comprising 50 Plugs, No. 8 (assorted lengths), Tool Holder, and 1 Bit, a supply of round head and countersunk Screws and Screw Eyes, Cup Hooks, Square Hooks, and instructions. Price $3\frac{6}{6}$ complete.

Mechanics' Outfits.

100 Rawlplugs (assorted lengths), Tool Holder, 2 Bits, and a supply of Screws, Hooks, etc. Set 6, $5\frac{-}{-}$; 8, $5\frac{6}{6}$; 10, $6\frac{-}{-}$; 12, $7\frac{-}{-}$; 14, $8\frac{-}{-}$; *16, $7\frac{-}{-}$; *18, $8\frac{-}{-}$; *20, $9\frac{-}{-}$ complete.
* Sets 16, 18, and 20 have only 50 Plugs.



MAKING THE HOLE



INSERTING THE PLUG



TURNING HOME THE SCREW



HOOP IRON PUNCH No. 1163W.



Size $4 \times \frac{1}{4}$ in. Price $\frac{-}{10}$ each.

HAND RAIL PUNCH No. 1164W. Price $\frac{-}{9}$ each

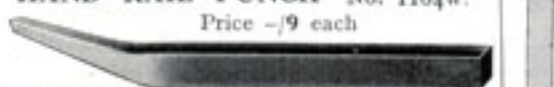

CAST STEEL NAIL SETS No. 1166W.



Length, 4 in. Price $\frac{-}{6}$ each; $5\frac{-}{-}$ per doz.

DRAWER LOCK CHISEL No. 1165W. Price $1\frac{6}{6}$ each.



NAIL HOLDER AND SET No. 1167W.



Price $1\frac{3}{3}$ each.

Electric and Wireless Engineers

RICHARD MELHUISE LIMITED, LONDON, E.C.

JOINERS' MALLET
 No. 1168w.

 Best Quality Hard Beech.
 Handles mortised square from top.
 Size... 4 4½ 5 5½ 6 7 in.
 Price 1/2 1/6 1/9 2/- 2/3 3/- ca.

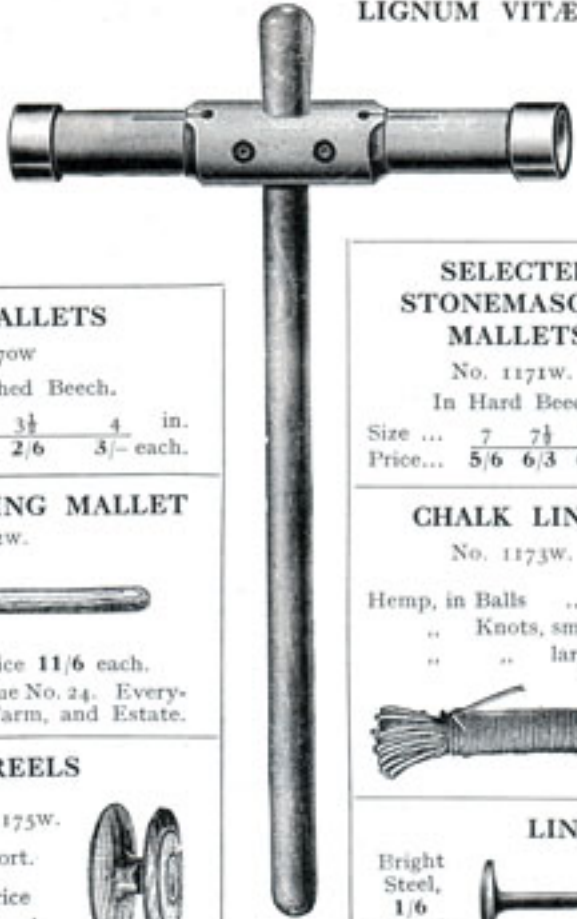
LIGNUM VITÆ CAULKING Mallet
 No. 1169w.
 Length of head, 12 in.
 Price 6/6 each.



CARVERS' MALLET
 No. 1170w.
 Polished Beech.
 Size ... 3 3½ 4 in.
 Price ... 2/3 2/6 3/- each.



SELECTED STONEMASONS' MALLET
 No. 1171w.
 In Hard Beech.
 Size ... 7 7½ 8 in.
 Price... 5/6 6/3 6/6 each.



TIMBER SPLITTING Mallet
 No. 1172w.
 Size 11 x 5 in. Price 11/6 each.
 Please write for Catalogue No. 24. Everything for the Garden, Farm, and Estate.



CHALK LINES
 No. 1173w.
 Hemp, in Balls -/8 each
 .. Knots, small -/2½ ..
 large -/3 ..



Best Cotton, about 20 yds., -/5 per knot.

BEECH CHALK LINE REELS
 No. 1174w. Long. Price -/5 each.
 No. 1175w. Short. Price -/4 each.



LINE PINS No. 1176w.
 Bright Steel, 1/6 per pair.



FORGED STEEL JOINERS' DOGS
 No. 1177w.
 Size 2 2½ in. Price 2/6 3/- doz.
 Size 3 4 in. Price 3/6 4/3 doz.



STEVEDORE HOOK
 No. 1178w.
 Black finish. Price 1/- each.



FORGED STEEL WOOL HOOKS
 No. 1179w.
 Approx. size, 6 x 4 in. Price 2/6 each.



FORGED STEEL COTTON HOOKS
 No. 1180w.
 Price 2/3 each.



SHIP SCRAPER No. 1181w.
 Socket Screwed. Size 5 in. Price 2/3 each.



SHIP SCRAPER No. 1182w.
 Total length, 25 in.; width, 2½ in. Price 1/6 each; 16/- per doz.



SHIP SCRAPER No. 1183w.
 Price 1/4 each; 14/- per doz.



SHIP CARPENTER'S PIN MAUL
 No. 1184w.
 Weight ... 3 4 5 lb.
 Price ... 2/3 2/9 3/3 each.
 See page 68 for various Handles.



BRIGHT STEEL SHIP CAULKING TOOLS
 No. 1185w. No. 1186w. No. 1187w.
 Straight, 2/3 each. Single Crease, 2/6 each. Double Crease, 3/- each.



Bronze Medal 1884—Gold Medal 1890

TOOL AND MACHINE MERCHANTS

COMPRESSED JOINERS' RUBBERS

No. 1188w.

No. 1189w.

No. 1190w.



Price ... -/4

-/5

-/6 each.

FILE CLEANERS

No. 1191w.



Price -/5 each, 4/6 per doz.

Write for quotations of Carbon Steel Files.
See our Metal Workers' Catalogue.

No. 1192w.

TOOL RACKS



Made from bright Spring Steel, in 24 in. lengths.

Size ...	1/4	3/8	1 in.
Will hold ...	20	14	10 tools.
Price ...	1/5	1/4	1/9 each.

AJAX CLEANER

No. 1193w.



Size, 6 x 2 in.

Price ... -/6 each.

RACKS FOR FILES, CHISELS, Etc.

No. 1194w.



12 in. long. Price 2/- ea.

No. 1196w.

FILE CARD



Size of wire, 4 1/2 x 1 1/2 in. Price 2/9 each.

COMBINED FILE BRUSH AND CARDING WIRE AT BACK

No. 1197w.



Price 4/3 each.

RACKS FOR HOLDING TWELVE BORING BITS.

No. 1195w.
Price 3/3 each.

IMPROVED PATENT ROUND METAL BOXES, WITH GLASS TOPS

No. 1199w.

For Nails, Screws, and small Fittings.

Particular attention is called to the special construction of these boxes, the chief feature of which is the close fit of the lid, rendering the boxes virtually air-tight, contents can be seen without removing the cover, combined with perfect ease in putting on or taking off the lids.

Size ... 1 1/2 x 1/2 2 x 1/2 2 1/2 x 1/2 in.
Price ... 2/3 3/- 4/- doz.



POLISHED BRASS TOOL CLIPS

No. 1198w.

Size per across.	doz.	Price
1/2 in. ...	2/-	
3/4	2/6	
1	3/-	



SPRING STEEL CLIPS

No. 1200w.

Size across.	Price per doz.
1/2 in. ...	1/6
3/8	1/9
1/4	2/-
1/2	2/4
1 1/4	2/8
1 1/2	3/-



RED VASELINE

No. 1201w.

In sealed tins. The best rust preventive.

Size 1/2 lb. tin. Price 1/6 per ..
Size 1 lb. tin. Price 2/- per ..



LEAK-PROOF OIL CAN

No. 1202w.

Price 1/3 each.

See page 70 for fully illustrated sheet of Oil Feeders, etc.



Engineers' Tools and Machinery

DOWEL SHAVER



No. 1203w.

Straight Pattern.

This will shave or trim rapidly the ends of dowel pegs. Size $\frac{1}{8}$ in. Price 1/10 each.

DOWELLING JIGS

For boring dowel holes in the edge, end, or surface of work. Will take any thickness of material up to 3 in. They are also a bit guide for mortising.



A Depth Gauge is furnished which can be used with or without the Jig.

No. 1206w. With 5 Guides (1 each $\frac{1}{8}$, $\frac{3}{16}$, $\frac{1}{4}$, $\frac{5}{16}$, and $\frac{3}{8}$ in.), nickel-plated 11/- each.

No. 1207w. With 9 Guides (1 each $\frac{1}{8}$, $\frac{3}{16}$, $\frac{1}{4}$, $\frac{5}{16}$, $\frac{3}{8}$, $\frac{7}{16}$, $\frac{1}{2}$, $\frac{5}{8}$, and $\frac{3}{4}$ in.), nickel-plated ... 16/- each.

DOWEL PLATES
No. 1204w.



Size $\frac{1}{8}$ in.
" "
" "
Price 2/9 each.
Size $\frac{3}{16}$ in.
" "
" "
Price 4/6 each.
Size $\frac{1}{4}$ in.
" "
" "
Price 5/9 each.

DOWEL POINTER

No. 1208w.

Price 2/3 each.

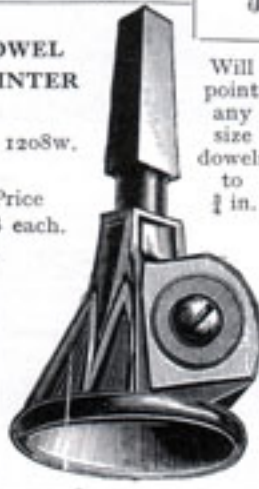

Will point any size dowels to $\frac{1}{4}$ in.

DOWEL ROUNDER



No. 1205w.

This little tool will round the ends of dowels perfectly.

Size $\frac{1}{8}$ $\frac{3}{16}$ $\frac{1}{4}$ in.
Price 2/- 2/- 2/- each.

DOWEL AND ROD TURNING MACHINE

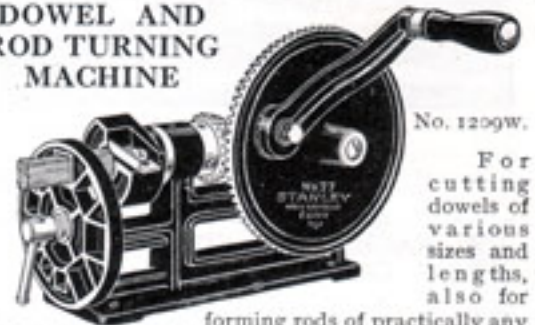

No. 1209w.

For cutting dowels of various sizes and lengths, also for

forming rods of practically any length. The crank can be adjusted for a long or short throw, giving power or speed to the machine as desired. One cutter head complete for making dowels or rods $\frac{1}{2}$ in. in diameter is furnished with each machine. Additional cutter heads with cutters $\frac{1}{8}$, $\frac{3}{16}$, $\frac{1}{4}$, $\frac{5}{16}$, $\frac{3}{8}$, $\frac{7}{16}$, and $\frac{1}{2}$ in. can be furnished if desired.

Japanned. Weight, 10 lb.

Price 47/6 each.

Extra Cutter Heads, 4/9 each.

DOWELS

In White Birch.

No. 1210w.



Diameter :	$\frac{1}{8}$	$\frac{3}{16}$	$\frac{1}{4}$	$\frac{5}{16}$	$\frac{3}{8}$	$\frac{7}{16}$	$\frac{1}{2}$	in.
Length :	36	36	36	36	36	36	42	..
Price :	7/6	8/-	8/6	10/6	12/6	13/6	15/6	26/6 100.
	1/-	1/-	1/3	1/6	1/9	2/-	2/3	3/6 doz.

AUGER HANDLE

No. 1211w.

This will hold and centre all sizes and shapes. Made of Hardwood. Length, 17 in. Price 3/6 each



ANGULAR BIT STOCK

No. 1212w.

This is used with an ordinary brace or breast drill and is an efficient tool for drilling at an angle. It can be used as a bit extension for straight work. Length, $12\frac{1}{2}$ in.

Price 10/9 each.



CORNER BIT BRACES

No. 1213w.

For corner work, when using a bit of ordinary size, these braces will work much faster than a regular ratchet brace.

The gears are of bevel type, the teeth carefully cut, and the whole mechanism enclosed to protect same from dirt as well as to guard the user's hands.

The quill is fastened to the head by three screws, one of which goes through that part of the frame where it enters the head, securely fastening all three together.

These braces are nickel-plated, metal-clad ball-bearing head, cocobolo head and handles, jaws forged, machined, and hardened, with springs for automatic release.

Size 8 in., price 24/6 ; 10 in., 26/9

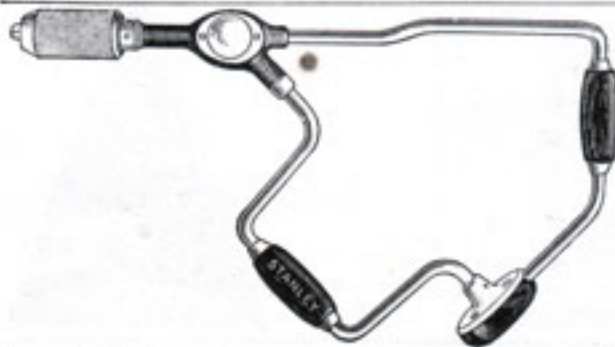

LIQUID AND OTHER GLUES

FOR WOOD, IRON, LEATHER, EARTHENWARE, IVORY, BRIC-À-BRAC, CHINA, GLASS, FURNITURE, ETC. ETC.



No. 1214W.

"Croid" has a breaking strain of 1,250 lb. to the square inch and is specified by the British Government for the construction of aircraft.

"Croid" is used cold at 63°-65°F. is of uniform strength, resists damp and heat, and does not deteriorate by keeping.

	2 oz.	1/2	1	7	14	28 lb.
Price ...	-/6	-/11	2/6	8/-	14/-	27/-

Standard Strength. *



No. 1215W.
In glass bottles,
with spreader.
Price -/10



No. 1216W.
In tin cans, as illustrated.

Price	1 gill,
	2/-
	1/2 pint,
	3/-
	1 pint,
	5/-
	1 quart,
	9/-
	4 quarts,
	30/-



No. 1217W.
Large tubes,
Price -/9

BEST SCOTCH GLUE

No. 1218W.

	1	7	14 lb.
Price ...	-/8	-/7	-/6 1/2 per lb.

SELECTED GELATINE GLUE

No. 1219W.

	1	7	14 lb.
Price ...	1/3	1/2	1/- per lb.

BEST FRENCH GLUE

No. 1220W.

Same prices as Scotch.

COPPER GLUE POTS

No. 1221W.

Recommended as being clean and light and quickly heated over a gas or spirit lamp.

No. ...	1	2	3
Holding, pints	1/2	1	1 1/2
Price ...	6/-	6/9	8/- ea.

No. ...	4	5
Holding, pints	1	2
Price ...	9/-	13/- each.



IRON GLUE POTS

No. 1222W.

The outer vessel or kettle has specially designed lugs, which ensure the handle remaining in an upright position when Glue Pot is placed on a fire or gas stove. The handle is thereby kept cool and clean, as it does not come into contact with heat or contents of Glue Pot.

The inner pot or cup is round at bottom and stands on an annular foot.

Price, with tinned inside linings.

No.	6/0	3/0	2/0	0	1	2	3
Holds pints	1/2	3/4	1	1	1 1/2	1 1/2	2
Price	2/9	3/6	4/-	4/6	5/-	6/-	7/6 ea.

No. ...	4	5	6	7	8	9	10
Holds, pints	2 1/2	3	3 1/2	4	5	6	8
Price ...	9/-	10/9	12/-	14/-	15/3	18/-	21/- ea.



SAFETY GAS GLUE POTS

GAS HEATED
WITH BURNERS
PROTECTED TO
SUIT THE
REQUIREMENTS
OF THE
INSURANCE
OFFICES.

These are made singly and also in sets of two and three of all the standard sizes of pots.
Outer casing of galvanised iron, Glue Pot cast iron tinned inside.

Prices of Glue Pots.

Sizes, pints.	Prices, extra.
1/2	2/6
3/4	2/6
1	3/8
1 1/2	5/-
2	5/-
3	7/3
4	9/6
5	9/6
6	12/3

No. 1223W.

Prices of Heater only.

To hold 1 pot	1/2-1 pt.	1 1/2-3 pt.	4 pt.	5 and 6 pt.
" 2 pots	23/6	26/6	32/6	38/-
" 3 "	52/-	52/-	52/-	79/-
	62/6	62/6	62/6	97/6



Illustration of One-pot Heater.

RICHARD MELHUISH LIMITED, LONDON, E.C.

BEST QUALITY FORK SASH TOOLS

No. 1224W.



String Bound, Lily Bristles.

No.	0	1	2	3	4	5	6	7	8	9	10	12
Price	7/6	8/6	9/8	10/10	11/1	12/3	13/6	14/2	15/3	16/6	17/6	18/6

each.

GLUE BRUSHES

No. 1225W.



Pressed Metal Ferrules, Bridled

Nos.	...	12	14	16	18	20	22	24
Price	...	9/-	1/-	1/2	1/10	2/9	3/3	4/-

each.

BEST QUALITY ONE KNOT GROUND BRUSHES

No. 1226W.



Copper Wire Bound.

Sizes	...	8/0	6/0	4/0	3/0	2/0
Price	...	16/6	15/-	13/6	10/6	9/-

each.

BEST QUALITY ROUND GROUND BRUSHES

No. 1227W.



Wire Bound.

Sizes	...	8/0	6/0	4/0	3/0	2/0
Price	...	16/6	15/-	13/6	10/6	9/-

each.

BEST QUALITY PAINTERS' DUSTERS

No. 1228W.



Round Wire Bound.

Sizes	...	8/0	6/0	4/0	3/0	2/0
Price	...	16/-	14/-	13/-	9/-	7/9

each.

BEST QUALITY JAMB BRUSHES

No. 1229W.



Black Bristles.

No.	...	1	2	3	4
Length of Bristles out of Stock	...	3 1/2	3 1/2	3 1/2	4 in
Price	...	2/9	3/3	4/-	5/-

each.

BEST QUALITY COPPER WIRE BOUND TWO KNOT DISTEMPER BRUSHES

No. 1230W.



Weight, 10 oz. Price 35/- each.

BEST QUALITY WASHING-DOWN BRUSHES

No. 1231W.



Weight, 8 oz
17/- each

No. 1232W. All Grey Bristles. 5 in. long. Price 5/6 each.

BEST NAILED STOCK BRUSHES

No. 1233W.



Leather Bound.
Yorkshire Pattern.

Weight	...	9	8	7	6	oz.
Price	...	25/-	22/6	19/6	16/6	each.
No. 1234W. Cheaper Quality.						
Width	...	4	4 1/2	5 1/2	6	in.
Price	...	3/3	4/-	5/6	6/6	each.

TWO KNOT COPPER BOUND DISTEMPER BRUSHES

No. 1235

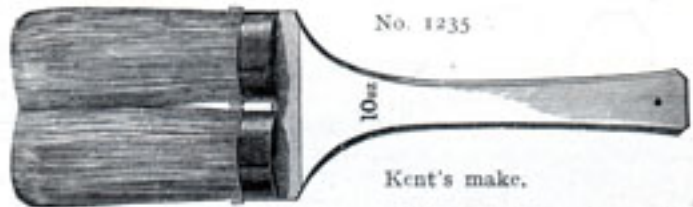

Kent's make.

Weight	...	12	11	10	9	8	oz.
Length of Bristle	...	6	6	6	6	5 1/2	in.
Price	...	27/6	23/6	22/-	21/-	18/-	each.

TAR BRUSHES

No. 1236W.



No.	...	1	2	3
Price	...	2/-	2/3	2/6

each.

No. 1237W.



No.	...	1	2	3
Price	...	1/3	1/6	2/-

each.

Electric and Wireless Engineers

TOOL AND MACHINE MERCHANTS

OVAL BEVELLED VARNISH

Nickelled Steel Ferrules.
No. 1238w.



Warranted to remain sound when used in Water, Turps, Oil, Varnish, or Paint.

Black Bess Brand (Regd.).

No.	1	2	3	4	5	6
Price	1/-	1/3	1/9	2/-	3/-	3/9 each.

OVAL VARNISH, BEST BRISTLES

No. 1241w.



Sizes...	6/0	4/0	3/0	2/0	1/0
Price	19/-	16/6	12/6	10/6	8/3 each.

BEST QUALITY FLAT VARNISH

No. 1239w.



Extra thick.

Width	1	1½	2	2½	3 in.
Price	-/10	1/3	1/6	2/6	3/- each.

No. 1240w. Medium thickness.

Width	1	1½	2	2½	3 in.
Price	-/6	-/8	1/-	1/4	1/6 each.

BADGER SOFTENERS

No. 1242w.

Medium Quality.



No.	1	2	3	4
Price	18/-	22/-	26/-	32/- each.

CAMEL-HAIR DABBERS

No. 1243w



Domed in Quill, Best Quality

No.	2	4	6	8	10	12
Price	-/6	-/9	1/1	1/6	1/9	2/3 ea.

CAMEL-HAIR MOPS

No. 1244w.



Domed, White Handles, Best Quality.

No.	2	4	6	8	10	12
Price	-/6	-/9	1/-	1/3	1/6	2/- each.

BEST QUALITY PAPERHANGERS' BRUSHES

No. 1245w.



Size	7	8	9	10 in.
Price	6/-	6/6	7/6	9/- each.



No. 1246w.

STIPLERS

White Bristles.					
Sizes	4 x 3	6 x 4	7 x 5	8 x 6	in.
Handle at end, price	12/6	21/-	27/-	36/-	ea.

White Bristles.					
Sizes	4 x 3	6 x 4	7 x 5	8 x 6	in.
Handle on back, price	12/6	21/-	27/-	36/-	ea.



No. 1247w.

No. 1248w.



Round.

HOG HAIR FITCHES

Round or Flat.

No.	1	2	3	4	5	6
Price	-/3½	-/3½	-/4	-/4½	-/6	-/7 ea.

No. 1249w.



Flat

MOUNT CUTTER'S STRAIGHT EDGE

No. 1250w.



Sizes	24 x 1½	30 x 1½	36 x 1½	48 x 2 in.
½ in. thick, price	5/-	7/6	11/6	17/- each.

Sizes	24 x 1½	30 x 1½	36 x 1½	48 x 2 in.
½ in. thick, price	12/-	13/6	18/6	25/- each.



REBATING GAUGE

No. 1251w.

For Picture Frames. With Adjustable Knife and Fence.

Price	2/6	each.
-------	-----	-------





Bronze Medal 1884—Gold Medal 1890

No. 1252W. BRIDLED FLAT VARNISH OR PAINT BRUSHES

FOR a long time past it has been felt what an advantage it would be if FLAT BRUSHES could be fitted with a serviceable Bridle, and with this object in view we have given this matter careful consideration. The great drawback to these Brushes in the past has been that they have of necessity been made with short bristles only, as if made with long bristles they lose their stability, the bristles spread and the Brushes wear only in the middle. After exhaustive experiments, we consider we have discovered the correct way of Bridling these Brushes, and we confidently recommend our New Patent Bridle to the trade. We contend that with the aid of our New Patent COMBINATION BRIDLE it is possible to use bristles of any length in the manufacture of FLAT VARNISH BRUSHES, etc. The advantages of this are at once apparent: the stability of the Bristles is maintained, and the life and general utility of the Brush is increased enormously.

DIRECTIONS FOR DETACHING BRIDLE

The method of detaching the Bridle is simplicity itself. All you have to do when the Bristles have worn down sufficiently, according to the requirements of the user, is to cut the band with a pair of scissors, etc., as shown in illustration No. 3, then bend the band on either side of the Brush backwards and forwards several times, as shown in illustration No. 4, when the connecting strip will at once snap off. The Brush is then ready for use again.

NEW BRUSH.	NEW BRUSH.	FRONT VIEW.	END VIEW.	OLD STYLE OF BRUSH.
				
FRONT VIEW.	SIDE VIEW.	Showing First process of detaching Bridle.	Showing Final detachment of Bridle.	HALF WORN.
Width	$\frac{1}{2}$ $\frac{3}{4}$ 1 $1\frac{1}{2}$	$1\frac{1}{2}$ 2 $2\frac{1}{2}$ 3	$3\frac{1}{2}$ 4
Price	-/5 -/6 -/8 -/10	1/- 1/4 2/- 2/9	4/- 5/6 each.

BRIDLED VARNISH OR PAINT BRUSH
Bevelled. Pure Black Bristles.

No. 1253W.



Size	1	2	3	4
Price	4/6	6/-	7/6	9/- each.

OVAL ONE KNOT COPPER BOUND DISTEMPER BRUSH

Grey middles. Treble String Bridle. Length of Hair, 5 in. Superior Quality.

No. 1254W.



Size	1	2	3	4
Price...	...	11/-	12/6	15/-	16/- each.

BRIDLED WALL BRUSH
No. 1255W.

For Paint or Distempers.
Rubber Set.
Metal Bridle.
Pure Black Bristles.



Width	$3\frac{1}{2}$	4	5	6
Price	7/-	8/6	12/-	22/6 each.

WALL BRUSH
No. 1256W.

Copper Bound and Bridled.
Length of Bristles, $5\frac{1}{2}$ in.

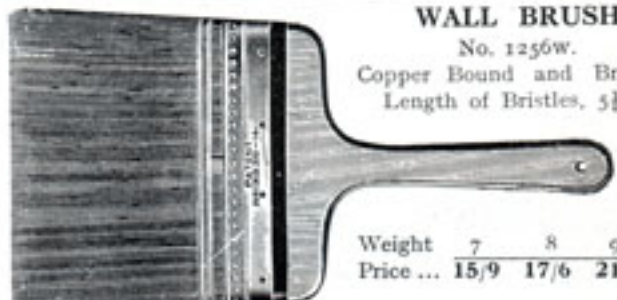

Weight	7	8	9
Price ...	15/9	17/6	21/- ea.

TOOL AND MACHINE MERCHANTS

INTERCHANGEABLE LOCK STENCILS IN ZINC

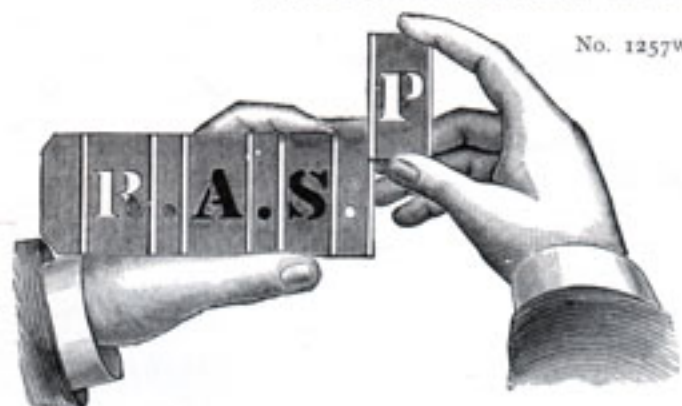

No. 1257w.

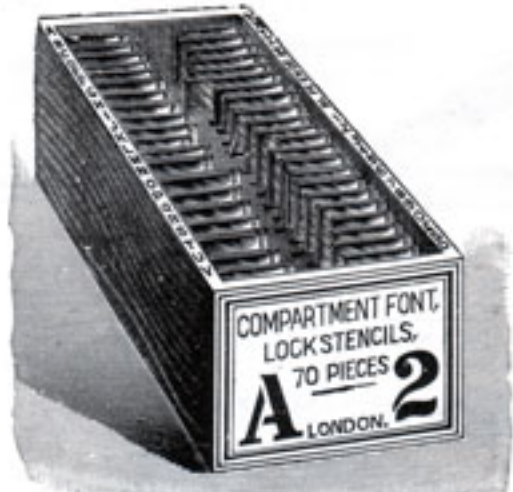

These have recently been improved to expedite putting together, which can now be done with almost the rapidity of an expert setting type.

A set contains two of each letter, except Q, X, and Z, of which there is one of each; one of each figure 1 to 9, two 0's, ten blanks, full stops, etc.

Price per Fount of 70 pieces in Wood Box with separate compartments as illustrated	$\frac{1}{2}$	$\frac{3}{4}$	1	$1\frac{1}{2}$	2	$2\frac{1}{2}$ in.
Extra Letters or Figures	10/3	10/3	10/3	13/6	18/9	23/3
These sets may be obtained in Spring Brass 50 per cent. on above prices.	-2 $\frac{1}{2}$	-2 $\frac{1}{2}$	-3	-4 $\frac{1}{2}$	-6	-7



ZINC STENCILS

No. 1258w.

In Sets containing Alphabet, Set of Figures, Ink, Brush, and Sponge.

Sizes	$\frac{1}{2}$	$\frac{3}{4}$	1	$1\frac{1}{2}$	2	$2\frac{1}{2}$ in.
Per set complete	6/9	6/9	6/9	10/3	13/6	17/-

ZINC STENCILS, LETTERS, AND FIGURES ON LOOSE PLATES

No. 1259w.

Sizes	$\frac{1}{2}$	$\frac{3}{4}$	1	$1\frac{1}{2}$	2	$2\frac{1}{2}$	3	4 in.
Letters, per set	2/9	2/9	2/9	4/6	6/-	7/6	9/-	12/-
Figures	1/-	1/-	1/-	1/6	2/-	2/6	3/-	4/-

CIRCULAR STENCILS No. 1260w.



As illustrated. Made of stout Zinc with wooden knob in centre for handling. Many prefer these to any type of stencil, and there is much to be said for their utility. Made in any size to fit barrel tops.
 1 in. size Figures 3/- ea.
 1 $\frac{1}{2}$ " " 3/6 "
 1 " Letters (3 discs to alphabet) 7/9 ea.
 1 $\frac{1}{2}$ in. size Letters (3 discs to alphabet) 10/6 ea.

STENCIL BRUSHES No. 1261w.



Price -/6, -/9, 1/-, 1/3 each.

STENCIL INK No. 1262w.

Black, in Tin ... 1/6 per tin.
 " Cake ... 1/- per cake.
 White, Red, and Green, in Tins... 1/6 per tin.

RING STENCILS No. 1263w.

Prices on application.



SETS OF LETTERS AND FIGURES. For Stamping Steel, Iron, Brass, etc.



In.	No. 1264w. Best Sheffield-made Sets. For Wood and Iron.		No. 1265w. Engineers' London-made Sets. For Steel.	
	Letters.	Figures.	Letters.	Figures.
$\frac{1}{2}$	7/6	2/6	13/6	4/-
$\frac{3}{4}$	7/6	2/6	13/6	4/-
$\frac{1}{2}$	10/-	3/4	14/6	5/-
$\frac{3}{4}$	10/-	3/4	15/-	5/-
$\frac{1}{2}$	11/3	3/9	20/-	7/-
$\frac{3}{4}$	13/6	4/6	23/6	8/6
$\frac{1}{2}$	18/-	6/-	32/6	12/6
$\frac{3}{4}$	30/-	10/-	42/6	14/6

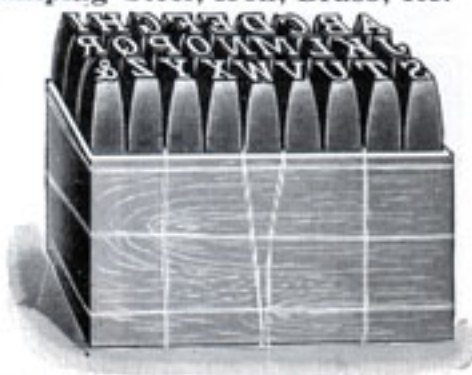

Builders' and Furnishing Ironmongery

RICHARD MELHUIH LIMITED, LONDON, E.C.

FRAMED MAHOGANY SET SQUARES

Ebony edged. Best quality.
Framed Hardwood Set Squares supplied to order.

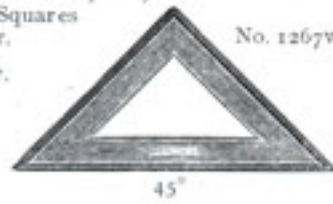

Size ...	60°				
	6	8	10	12	in.
45° ...	6/-	8/-	10/-	12/-	each.
60° ...	5/9	6/6	10/-	12/-	"

TRANSPARENT SET SQUARES

No. 1270W.

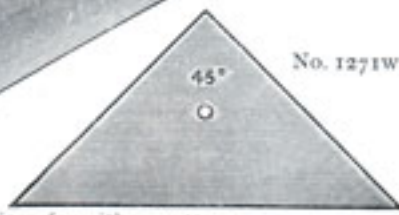

Prices for either pattern.

Size ...	4	5	6	7	8	10	12	in.
45° ...	1/-	1/1	1/4	1/6	2/-	3/-	4/-	each.
Size ...	5	6	7	8	10	12	in.	
60° ...	-/8	-/10	1/2	1/6	2/-	3/-	each.	

EBONISED PARALLEL RULES

No. 1274W.

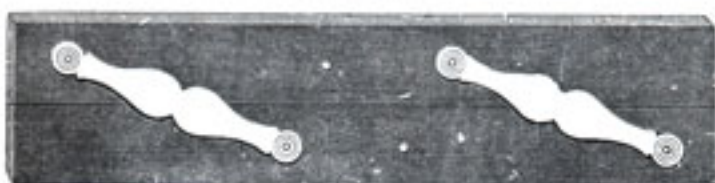

Length ...	9	12	15	18	in.
Price ...	2/6	3/6	4/-	5/-	each.

BEST ENGLISH SHAPED T-SQUARES

No. 1276W.

Of best polished Mahogany, with taper Blade, edged with Ebony, and warranted True.

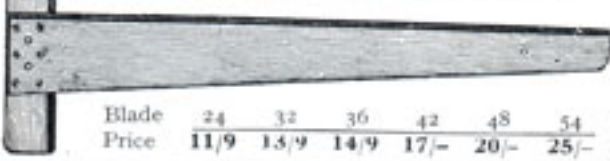

Blade	24	32	36	42	48	54	in.
Price	11/9	13/9	14/9	17/-	20/-	25/-	each.

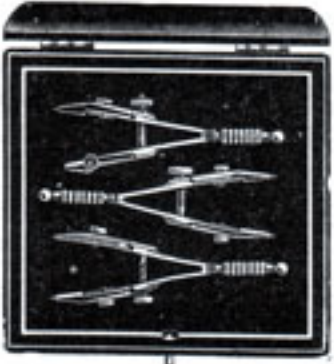

SET OF SPRING BOWS

No. 1278W.

In neat Case.

Electrum and Steel.

Price complete ... 12/6

SET SQUARES, HARDWOOD

No. 1268W.

No. 1269W.

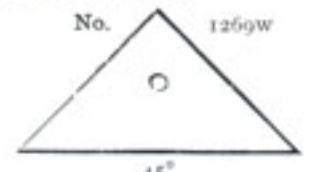
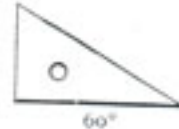

Size ...	5	6	8	10	in.	Size ...	4	5	6	8	in.
Price	-/2	-/3	-/4	-/7	each.	Price	-/2½	-/3½	-/4	-/7	ea.

DEAL DRAWING BOARDS

Clamped, No. 1272W.



ARCHITECT'S AND ENGINEER'S DRAWING BOARD

No. 1273W.

Made of selected Deal, with battens and Brass slots, grooved back and Ebony edges.



Size.	Price
23 x 16 in. ...	17/6
28 x 21 " ...	26/-
32 x 23 " ...	27/6
41 x 28 " ...	40/-
42 x 29 " ...	46/-
54 x 32 " ...	58/-

Prices for Second quality Engineers' Drawing Boards on application.

PEARWOOD T-SQUARES WITH TAPER BLADES

No. 1275W.

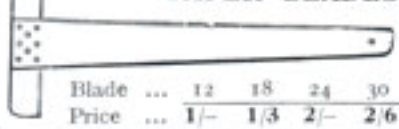

Size.	Price.
23 x 16 in. ...	8/-
24 x 19 " ...	10/-
28 x 19 " ...	12/6
31 x 23 " ...	16/-

Blade ...	12	18	24	30	36	in.
Price ...	1/-	1/3	2/-	2/6	3/-	each.

UNIVERSAL ADJUSTABLE SQUARE

No. 1277W.

Transparent Celluloid.

Plain edges, not bevelled.

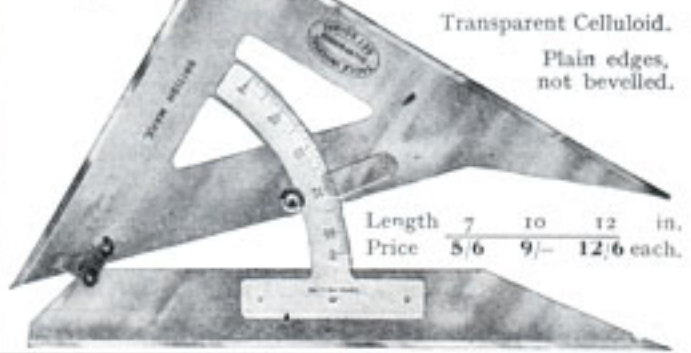

Length	7	10	12	in.
Price	5/6	9/-	12/6	each.

BOXWOOD SCALES

No. 1279W.



12 in. Universal or Builder's Scale, oval top ...	2/-	each.
12 " Architect's Scale, flat section, as Illustration ...	2/-	"
12 " Armstrong " oval section, 8 scales ...	1/6	"
12 " Engineer's " " " 4 " fully divided ...	3/-	"

DRAWING INSTRUMENTS



USEFUL SET OF INSTRUMENTS, IN WOOD BOX

No. 1290W.

Containing 4½ in. Compass, with changing points, 4 in. Divider, Drawing Pen, Rule, Crayon Holder, and Protractor.
 Price complete 9/- each.

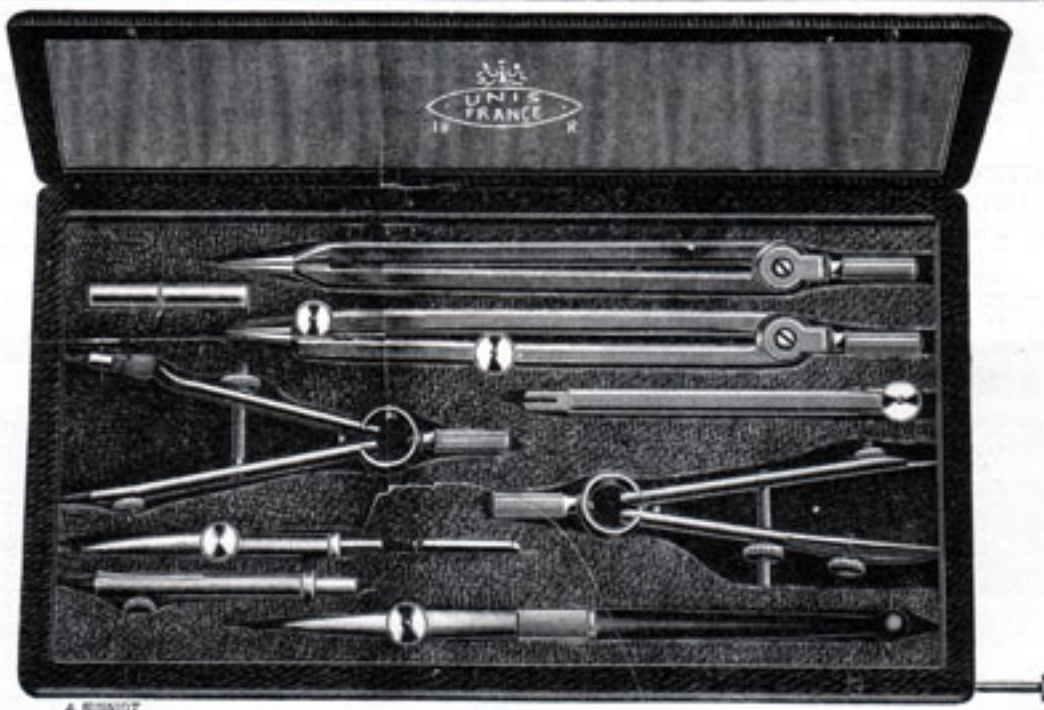

SET OF INSTRUMENTS

No. 1291W.

In Imitation Morocco covered Pocket Case, with Rod Fastener. Containing Bow Compass, Bow Pen, Pencil, Lengthening Bar, Drawing Pen Divider, Spring Bow and Pencil, and Case of Leads.

Price complete, in Brass 14/6 each.
 " " Nickel Silver 15/9 "

Bronze Medal 1884—Gold Medal 1890

TOOL AND MACHINE MERCHANTS

DRAWING INSTRUMENTS



SET IN ROSEWOOD BOX No. 1292w.

Containing 4½ in. Compass, with changing points, 4 in. Divider, Drawing Pen, Rule, Crayon Holder, and Protractor. Price 16/6 each.

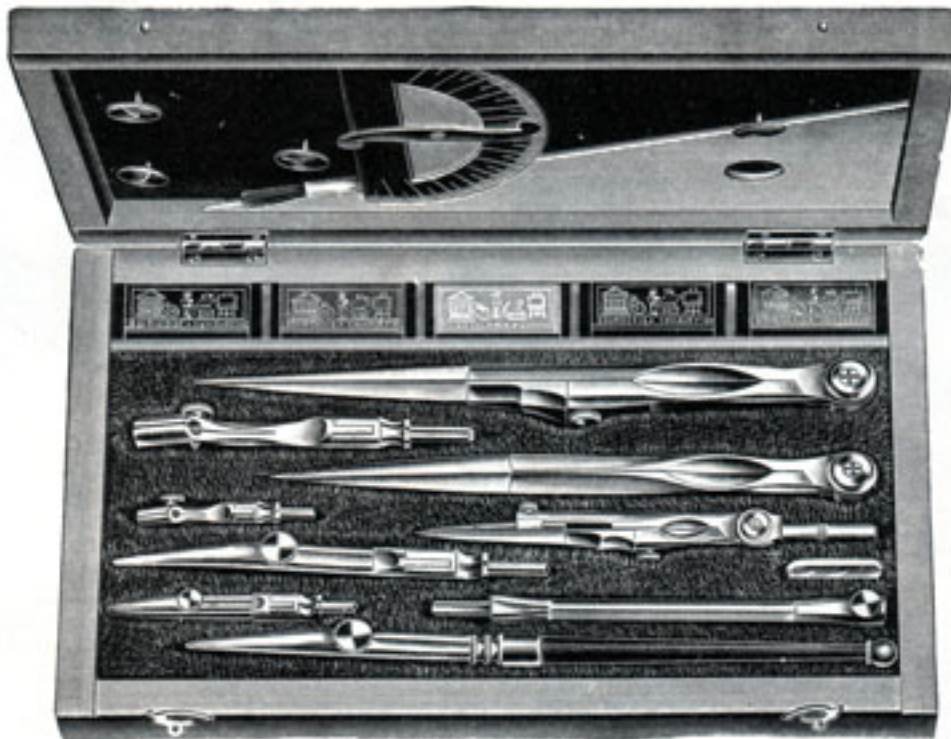

SET OF INSTRUMENTS No. 1293w.

Containing 5½ in. Compass, with changing points, 4½ in. Divider, Bow Compass Pen, Rule, and Protractor, Set Square, Drawing Pins, and 6 Water-colour Paints. Complete in Wood Box. Price 12/6 each.

Engineers' Tools and Machinery

LIGHT PATTERN SAW BENCHES



No. 1294w.

This has been built to meet the demand for a cheap and reliable Bench suitable for farm and general work. The spindle is of steel and runs in long gun-metal bearings. The fence can be turned back for cross cutting and set for bevel cutting.

Size of top.	Size of Saw.	Speed.	Pulleys.	Price.
45 x 21 in.	24 in.	800-1,200 r.p.m.	7 x 3 in.	£15 : 10 : 0

No. 1296w.

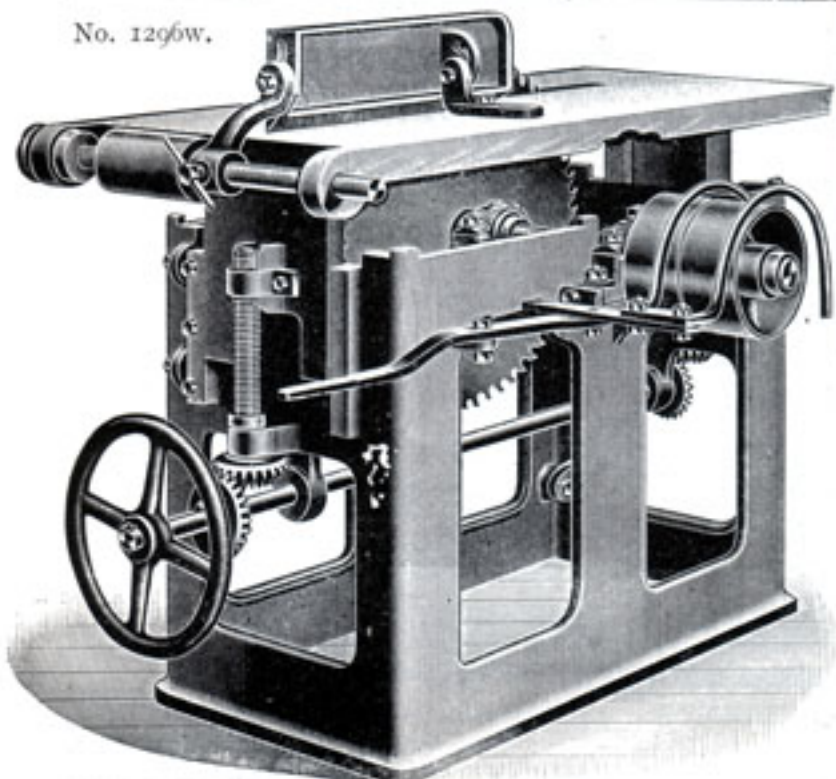

These Benches are made to supply a demand for light work, cross cutting, etc. They are well fitted and have a sliding fence and planed top. They have also long gun-metal bearings and rigid frames.

Prices complete with saw, pulleys, and belt shifter.

	Size of Top. In.	Takes Saw. In.	Size of Pulleys. In.	Speed. R.p.m.	Price.
No. 1	36 x 18	18	6 x 3	1,000	£8 : 10 : 0
" 2	42 x 20	22	7 x 3	1,200	£10 : 0 : 0
" 3	48 x 24	24	7 x 3	1,200	£11 : 0 : 0

These Benches can be supplied with ball bearings instead of gun-metal for 25/- extra.

No. 1295w.



This pattern is constructed for constant and accurate work, tonguing, grooving, rebating, cross cutting, etc. Saw spindle is steel and runs in gun-metal dustproof self-oiling bearings. The table rises and falls about 8 in.

	Size of Top. In.	Takes Saw. In.	H.P. reqd.	Price.
No. 1	48 x 24	30	4-6	£34 : 0 : 0
" 2	60 x 28	36	6-8	£46 : 0 : 0

Goods on this page Carriage Forward.

Builders' and Furnishing Ironmongery

TOOL AND MACHINE MERCHANTS

PEDESTAL SAW BENCHES

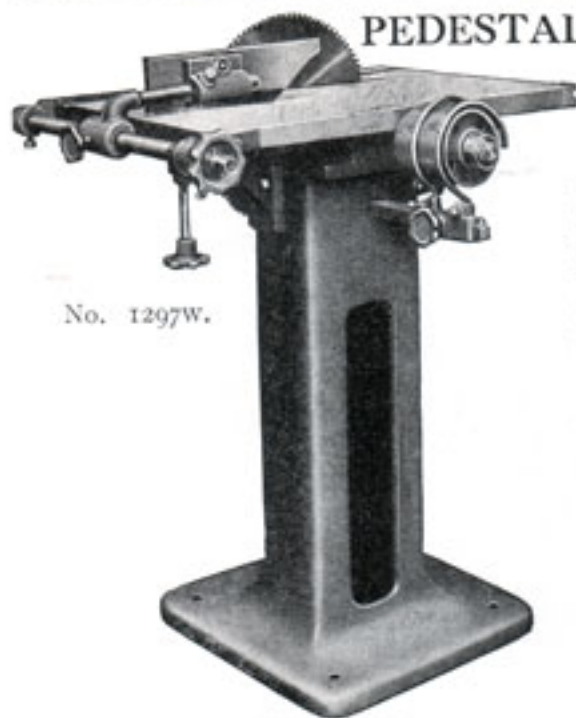

No. 1297W.

With Tilting Table.



No. 1298W.

With Parallel Rise and Fall Table.

A first-class tool for fine accurate work, occupying the minimum of floor space, and having all the usual adjustments, plus the new underneath saw guard, as required by the Board of Trade.

Either of these patterns can be fitted with Boring Attachment having rise and fall grooved table 13 x 12 in.

No. 1297W.	1	2	3	4	5	6
Takes saw diameter	12 in.	12 in.	14 in.	14 in.	16 in.	16 in.
Bearings	Gun-metal.	Ball.	Gun-metal.	Ball.	Gun-metal.	Ball.
Approximate Net Weight, cwt.	2½	2½	2½	2½	4½	4½
Gross	4	4	4	4	17	17
Approx. Shipping Space, cub. ft.	16	16	16	16	2-3	2-3
H.P. required	1-1½	1-1½	2	2	2-3	2-3
Price, unpacked	£15 : 0 : 0	£15 : 10 : 0	£16 : 0 : 0	£16 : 10 : 0	£17 : 0 : 0	£17 : 10 : 0

No. 1298W.	Takes Saws.	Bearings.	Net Weight.	Gross Weight.	H.P.	Price.
No. 1	14 in.	Ball.	2½ cwt.	4 cwt.	2-3	£18 : 0 : 0
" 2	16 "	"	3 "	4½ "	2-3	£19 : 0 : 0
" 3	18 "	"	4 "	5½ "	4	£20 : 0 : 0

Extra for underneath guard, 15/-

RELIANCE SAW GUARD

No. 1299W.

This Saw Guard more accurately meets the requirements of the Board of Trade than any other.

ADVANTAGES.—Both sides of the Saw Blade are covered.

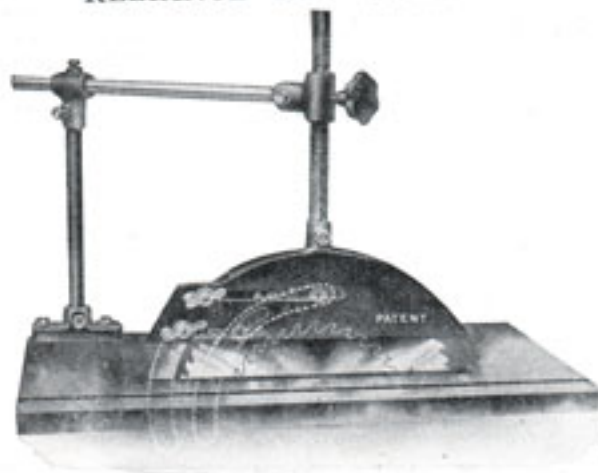

AN IMPORTANT FEATURE

The Riving Knife is adjustable in the slots at the top, and can be moved to approximately follow the circle of the Saw, when saws are changed to smaller sizes, as indicated at dotted lines in illustration.

For Saws	12	14	16	18	20	24	26	30	36	42	48 in.
Price	£1 : 18	£2 : 6	£2 : 16	£2 : 18	£3 : 3	£3 : 14	£4	£4 : 7 : 6	£5 : 15	£6 : 18	£8 : 10

All Carriage Forward.

Horticultural and Estate Appliances

No. 1300W.

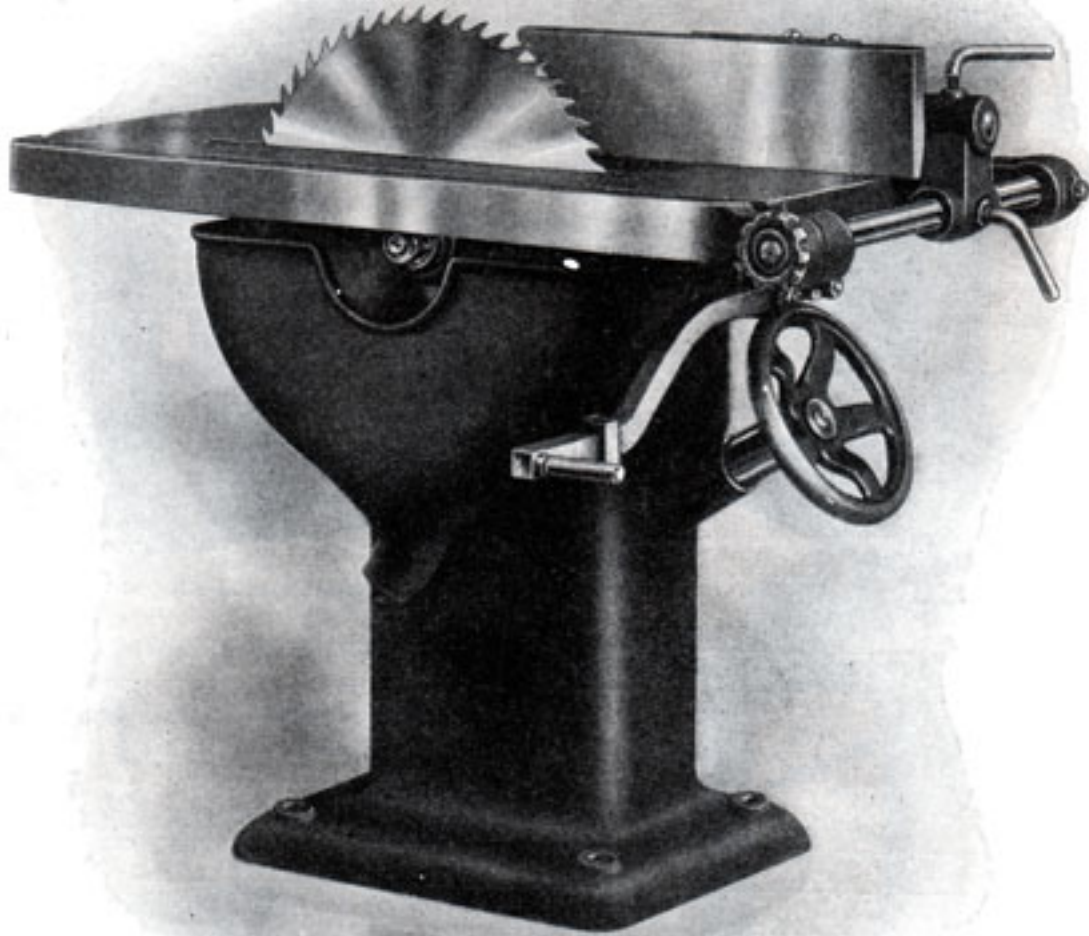

18 IN. IMPROVED CIRCULAR SAW BENCH

WITH RISING AND FALLING TABLE AND BALL BEARINGS.

That the bearings of woodworking machinery are of vital consideration is admitted. The success of our introduction of ball bearings to planing machines, band sawing machines, etc., has induced us to design an entirely new small Rising Top Circular Saw Bench.

The Frame is a strong cored casting in one piece, carrying the table, which is accurately machined on top and edge, and is arranged to rise and fall by a very conveniently placed hand wheel and screw motion. The raising screw is fitted with a ball thrust bearing, enabling the table to be raised with ease and rapidity.

The Saw Spindle is of best steel, and is fitted with ball bearings of the finest manufacture. They are mounted in dust-proof housings filled with grease. The bearings never require adjustment; the grease will last for months without renewing. These bearings are more costly to fit than plain bearings, but as they effect a saving of upwards of 70 per cent. of the friction load, the extra cost is saved in a few months in power alone, and, in addition, considerable savings are effected in oil, wear and tear of belting, time, and upkeep.

Attention has been paid to all other details of this Bench. The fence is of improved type with sliding front plate; quick and fine screw adjustments; will cant to any angle for bevel cutting; will turn over, leaving table clear for cross-cutting. The belt motion is handily placed for the operator, and will not creep. Fast and loose pulleys are fitted.

This is a most useful type of small Saw Bench, suitable for general sawing, cross-cutting, tenoning, grooving, rebating, boring, and light moulding if fitted with cutter block. It occupies little space, and is undoubtedly the finest machine of its type on the market.

Dimensions of Table.	Takes in Saws.	Depth will cut.	Diam. of Pulleys.	Revs. per min.	PRICE.	SHIPPING PARTICULARS.	
						Gross Weight.	Cubic Feet.
3 ft. x 1 ft. 6 in.	18 in.	6 in.	6 in.	1,800	£32 : 0 : 0	800 lb.	16 c.f.

Carriage Forward.

Electric and Wireless Engineers

BALL-BEARING CIRCULAR SAW BENCH

No. 1301W. Colonial Type

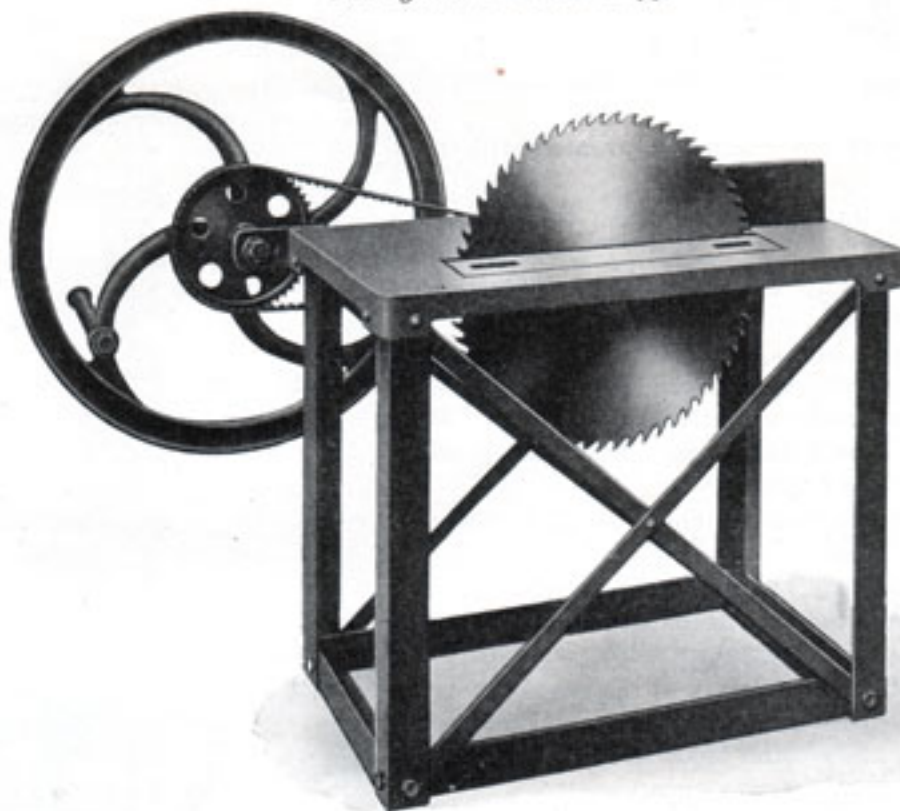

The Machine illustrated represents our latest design Circular Saw Bench, and has found considerable favour amongst users on account of its lightness, rigidity, and smooth running. It is constructed entirely of steel and iron, the table being extra strong and accurately planed and fitted with a gap piece to enable saw to be taken out easily when required. It is fitted with a long adjustable iron fence, which can be turned over end of Bench out of the way for cross-cutting purposes, and the table is marked off in inches parallel to saw to facilitate the setting of fence.

The Spindle is of steel and fitted with plates and nut for clamping saw, and one fast pulley. It is bored at pulley end to carry boring bits, for boring holes as required, and this work can be done with great speed and accuracy. A Boring Table can be supplied if desired, but this is usually built up by customer to suit his own requirements.

Ball bearings are fitted to the saw spindle.

For shipping and transport purposes the Bench can be taken to pieces and put into a small case, and it is so constructed that nothing can possibly be out of truth when Bench is again put together.

This Saw Bench can be supplied with table and spindle complete, but without steel framework, customer providing his own wooden frame to suit any special requirements.

To take Saws up to	22 in. diameter.
Size of Table	40 in. long x 20. in wide.
.. Pulleys (if for power)	4 in. diameter x 3 in. wide.
Speed	1,600 revolutions per minute.

For Hand Power, fitted with Flywheel and Chain Drive (as illustrated)	£18 0 0
.. .. . direct on to Spindle (no Chain Drive)	£16 0 0
For Power, fitted with Fast and Loose Pulleys direct on to Spindle (no Chain Drive)	£17 0 0
.. .. . Fast Pulley only direct on to Spindle (no Chain Drive)	£15 0 0

PRICES DO NOT INCLUDE SAWS. SEE PAGE 56.

Bronze Medal 1884—Gold Medal 1890

RISE AND FALL SPINDLE SAW BENCH

No. 1302w.
Taking 24 in. Saw.
ADVANTAGES:

Being a fixed table, supports can be fixed at the back for long work.

Raising and lowering of the spindle is operated with the greatest ease.

Belts do not alter in length when adjusting the height of spindle.

Fence swings away, leaving the table top clear for cross-cutting.

This Machine is designed to meet the demand for a Rise and Fall Spindle Saw Bench, having the advantage of a fixed table (and rise and fall spindle), obviating the disadvantage of the belt altering in length when adjusting the spindle, and is self-contained. No countershaft required.

THE TABLE is accurately planed and grooved to receive fence for mitre or cross-cutting.

THE SPINDLE runs in ball bearings, and is carried upon a strong bracket hinged from the back of the Machine and carried to the front, to receive the hand wheel for raising and lowering.

The usual matchpiece against the saw is dispensed with, as the saw can be removed by lowering the spindle; and provision is made in the table to receive cutter block for moulding, etc.

The Fence is of the canting turnover type.

An adjustable belt shifter is provided to work from any position of drive.

A Boring Table can be fitted at a small extra cost.

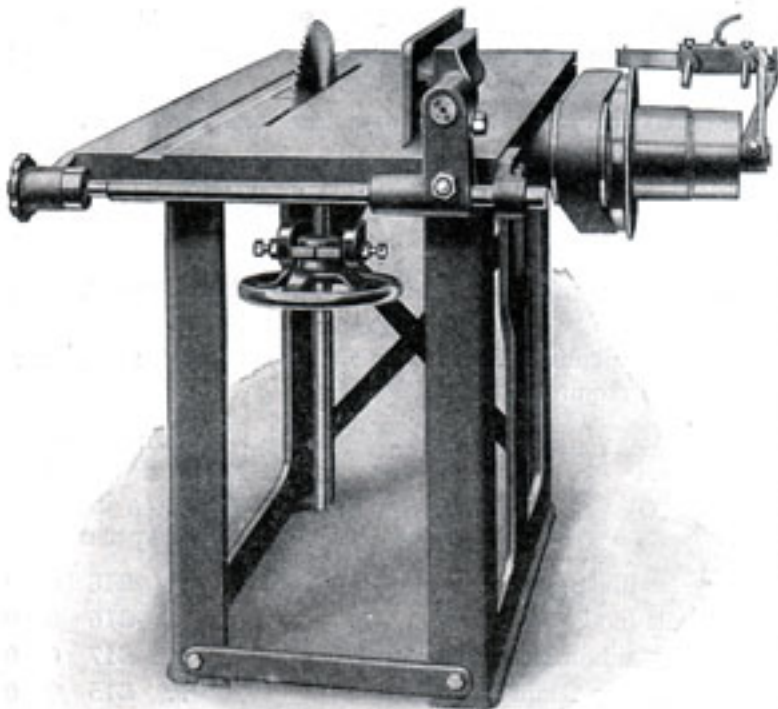

Carriage Forward.

BALL-BEARING JIG SAW

No. 1303w.

Size of Table, 29 x 26 in.; distance between arm and Saw, 30 in.

Illustration shows Canting Table, but Machines are also built with Fixed Tables.

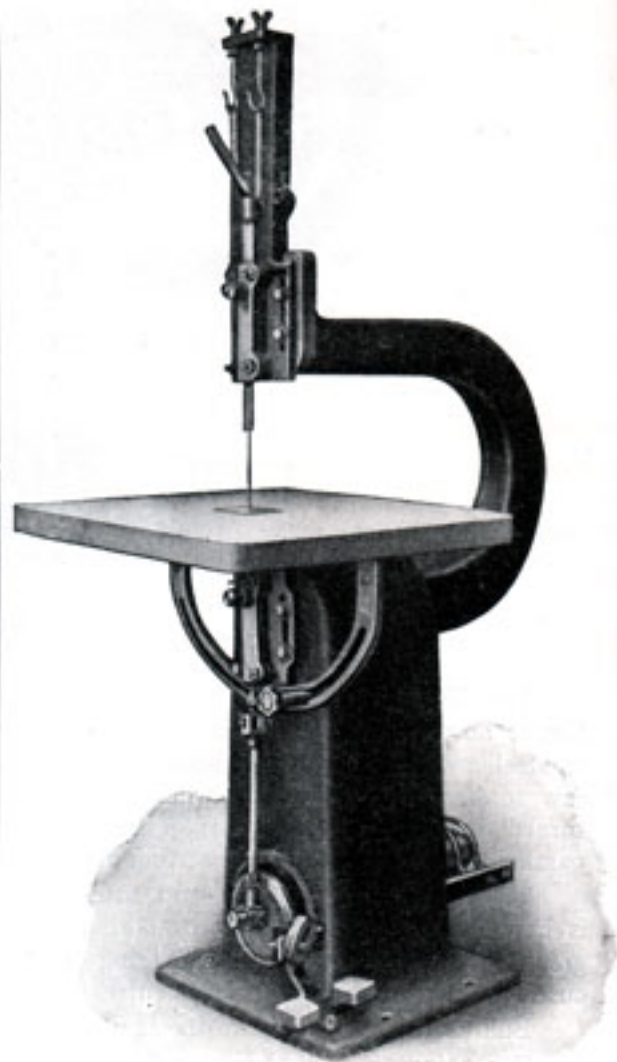

Price, with Fixed Table... .. £25 : 0 : 0
 .. Tilting £28 : 0 : 0

Size of Table.	Take Saw diam.	Diameter of Pulleys.	Saw Speed.	Weight.	Shipping Weight.	Shipping Measurement.
44 x 22 in.	24 in.	6 x 3 in.	1,200	4 cwt.	5 cwt.	10 cub. ft.
		Speed.	720			

Distance between Saw and Fence, 14 in.

Complete with Saw ... price £23 : 10 : 0

PATENT TREADLE SAW BENCH

No. 1304W.

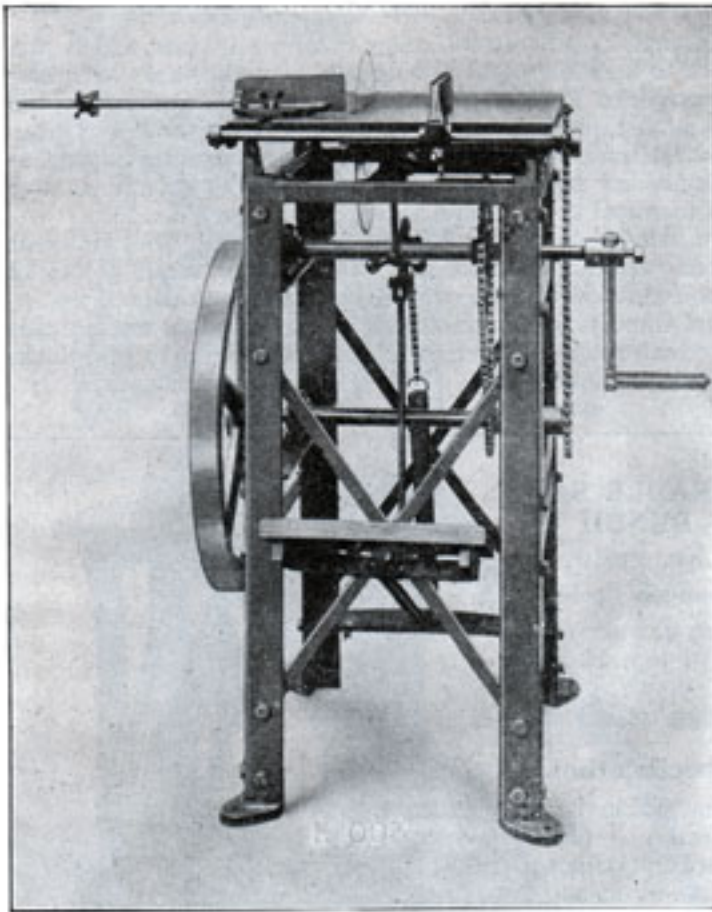

The framework is tied together by strong steel bars, and a most substantial construction is attained. The bottom ends of the frame rest on cast iron feet drilled to bolt to the floor.

The drive is taken from the treadle to the first motion shaft by means of a chain passing over a ratchet wheel. This chain terminates at the other end in a heavy spring. It is attached to the treadle by a "D" piece.

The gear wheel on the first motion shaft is of the free-wheel type, so that after the operator has pressed the treadle down with his foot the spring action causes it to fly back to the top position quickly, and the next downward motion can commence. **There are therefore no dead centres.**

The result is to save 75 per cent. of the time occupied by the treadle in an old-fashioned machine in completing the second half of its revolution, and the operator can get in a correspondingly greater number of strokes with a consequent reduction in effort.

From the first motion shaft the chain drive proceeds to a second motion shaft carrying a heavy flywheel running at a high speed and geared by chain to the saw spindle, which is thus made to run at a much higher speed than in other makes, giving a cleaner cut and enabling the work to be done with less effort.

The net result of the design is to give a flywheel speed six times greater than in the old designs, and since the flywheel effect varies as the square of the speed, **there is 36 times more stored energy behind the saw than in the old designs.**

It will thus be seen that the quick return of the treadle, the absence of dead centres, and the heavy flywheel effect confer unique advantages on the bench and render its operation far less laborious and much more pleasant than in the old types.

HAND OPERATION.—Should it be desired to operate the bench by hand, the second motion shaft is equipped with a handle, and by turning it at an easy rate the same speed can be attained as with the treadle.

TABLE.—The table is of heavy design, being accurately planed with wide groove for a swivelling mitre fence. It is pivoted at one end, so that it can be tilted by means of a lifting screw to enable grooving and rebating to be done.

BEARINGS.—The bearings are of high-class construction, consisting of heavy plummer blocks, with renewable bushes, so that the machines will run for long periods, and when the bushes wear they can easily be adjusted.

FENCE.—A sliding fence is provided which is carefully planed, and is accurately positioned.

MITRE FENCE.—This consists of a swivelling mitre fence and dead-length gauge which can be set so as to cut off work at any desired angle and to any desired length. This unique device is of great service for repetition work.

SAW.—A general purposes wood saw is included. Special saws can be supplied, but may not be stocked. For cutting metal, fibre, and special materials a full specification of the work to be done should be sent. This will be examined by experts and a suitable saw provided.

The whole Machine is a revolutionary advance upon all previous designs, and will prove an immense boon to the small woodworker.

Size of table, 20 x 16 in.; size of saw, 8 1/2 in. Complete with saw swivelling mitre fence and length gauge. Price £15 : 0 : 0
If with Ball Bearings, £2 : 10 : 0 extra.



FOR TREADLE

No. 1305W.

Size of table, 2 ft. x 1 ft. 8 in.; to take up 12-in. saw; weight, 3 cwt. 1 qr. 16 lb.

Price (as illustrated, with 8 in. saw) £12 : 17 : 6

FOR POWER

No. 1306W.

Size of table, 2 ft. 6 in. x 1 ft. 8 in.; size of pulleys, 6 x 2 1/2 in.; weight, 3 1/2 cwt.; to take up to 18 in. saw.

Price (with 12 in. saw) £14 : 0 : 0

Saw guard, 25/- extra.

These are very strong Benches and quite reasonable in price. Both have elevating tables. The depth of cut can be regulated by means of hand wheel. Both Benches are fitted with straight guide so that various widths may be cut; also angular guide for cutting any degree desired. Boring apparatus for power machine can be had for 60/- extra.

All Machines Carriage Forward.



Builders' and Furnishing Ironmongery

LIGHT PATTERN CIRCULAR SAW BENCH

A FINE LITTLE MACHINE FOR MOSAIC WORK, OR GEOMETRICAL INLAY.

This small Treadle Circular Saw takes a 4 in. saw, and is provided with a sliding table moving parallel with the saw on accurately machined V-slides. The table is machine graduated, and has an adjustable fence which can be set to any angle.

This Machine is specially suited for geometrical inlaying, as any number of squares, triangles, rhombus, or rhomboids may be cut identical in size and accurate in shape.

Most delightful patterns can thus be formed from different coloured varieties of wood, and in this way small pieces of fretwood which would otherwise be wasted are put to good use.

Apart from its use for geometrical inlay or wood mosaic, this Machine can be used for general cutting of wood up to $\frac{3}{4}$ in. thick.

Price complete. 60/- Carriage Forward.
Spare Saw, 4 in. diameter, price 7/6.

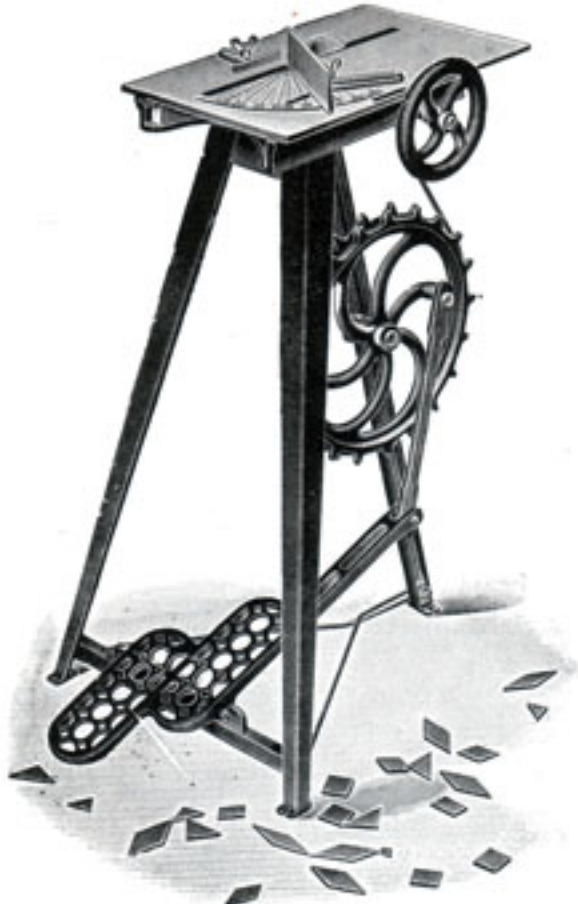

No. 1307w.

TREADLE SAW BENCH

No. 1308w.

London made.

Size of saw, 9 in.;
size of top, 18 x 19
in.; depth of saw
through top, 2 $\frac{1}{2}$ in.

Specification.

The Table is an accurately planed surface and is hinged, so that by means of the elevating screw



Carriage Forward.

the amount of saw projecting through table can be varied. The table and spindle supports are one casting; by this means the alignment of the principal parts of the Machine are always correct.

The Spindle is of steel, with glass hard ends, and revolves on glass hard centres, making a very light running machine.

The Straight Guide is adjustable so that various widths can be cut.

The Angular Guide, as shown in illustration, has a constant angle of 45°. Holes are drilled on face so that pieces can be fixed on to suit the desired constant angle required.

Price £16 : 10 : 0. For Treadle and Power. £18 : 10 : 0.

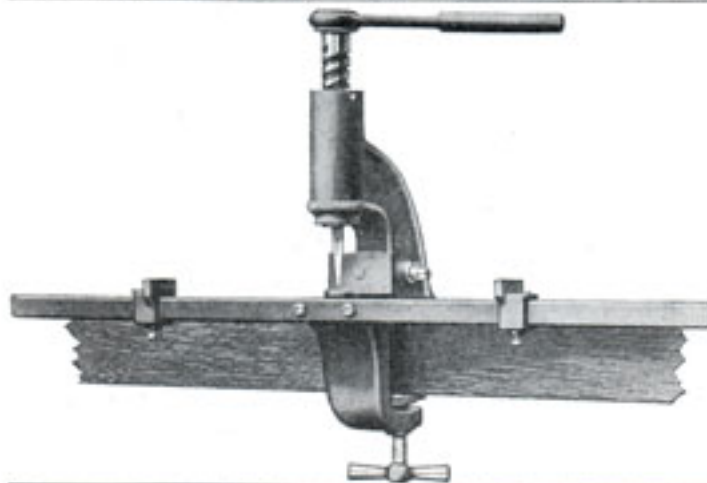

PORTABLE SLATE HOLING MACHINE

No. 1309w.

Illustration shows a new pattern which for general purposes cannot be excelled. It can be either clamped to a plank as illustrated or bolted to a bench. All parts are made of the best obtainable material, and the workmanship leaves nothing to be desired.

Weight, 30 lb. Price 50/- each.

TOOL AND MACHINE MERCHANTS

IMPROVED PATENT FOOT POWER SCROLL SAW

No. 1310W.

This is a very powerful Saw, starting instantly the treadle is pressed down, very easy motion, and with reasonable practice will cut Pine Wood 3 in. thick, at the rate of 1 ft. per minute, or Walnut 1 in. thick, 2 ft. per minute; other woods and thicknesses in proportion.

The space under the arm from the Saw is 24 in., and the Saws are 7 in. long. The table and arms are of hard Maple, and the frame is cast iron, strong, yet light.

The balance wheel runs on a steel arbor.

We include one dozen Saws with each Machine.

This Machine is designed for practical service in the workshops of cabinet makers, carpenters, and builders, and other workers in wood.

Price £9 : 10 : 0 complete, packed safely in Case. Machine takes 8 in. saws. Price 3/- per doz.

Carriage Forward.



BENCH BANDSAW

No. 1311W.

This is fitted with 14 in. tyred pulleys and tilting table, also adjustable swivel head. No up-to-date shop should be without one of these Machines. Suitable for pattern makers, cabinet makers, etc.

Price £12 : 10 : 0, with one Bandsaw ready for use.



BANDSAW SOLDERING DEVICE No. 1312W.

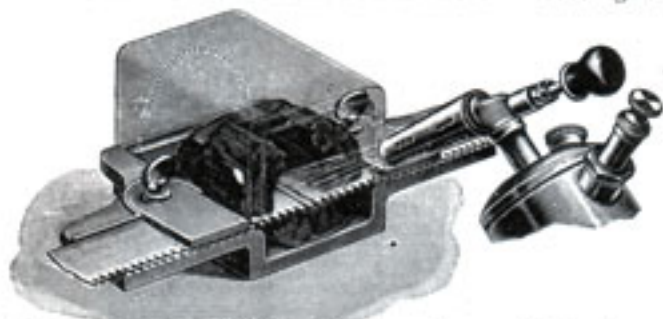

Price 12/6 each. Lamp 11/6 extra.

SAW GULLETING APPARATUS

Illustration shown is of a special design, and can be combined with our Plane and Moulding Iron Grinding Machine, so that it may be used for gulleting saws up to 36 in. diameter.

Price £5 : 10 : 0 each.

No. 1313W.



Electric and Wireless Engineers

SAW SPINDLE



No. 1314w.

See page 56 for
Circular Saws.

Steel Spindle with hardened ends, Steel Nut and Malleable Iron Collars.

No	...	1	2	3	4	5
Size	...	5 x 1/4	5 x 3/8	6 x 1/2	7 x 3/4	8 x 1 in.
Price	...	1/9	2/-	2/6	3/3	4/6 each.

SAW SPINDLE No. 1315w.
Fitted with Plummer Blocks and Pulley.

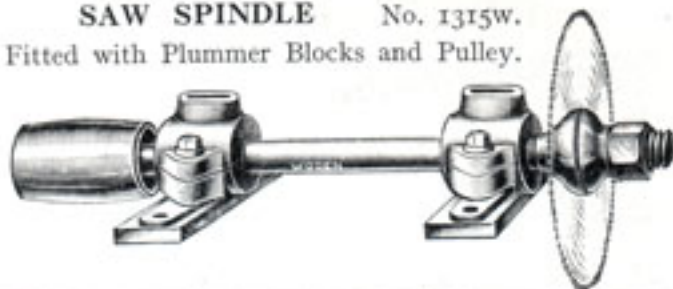

Size.	No. 1.	No. 2.	No. 3.	No. 4.
Length over all ...	17 in.	20 in.	23 in.	26 in.
Diam. of Spindle at Saw end ...	1	1 1/2	1 1/2	1 1/2
Price ...	27/6	32/6	48/-	57/6 each.
If fitted with fast and loose pulleys ...	32/-	39/6	59/6	67/6 ..

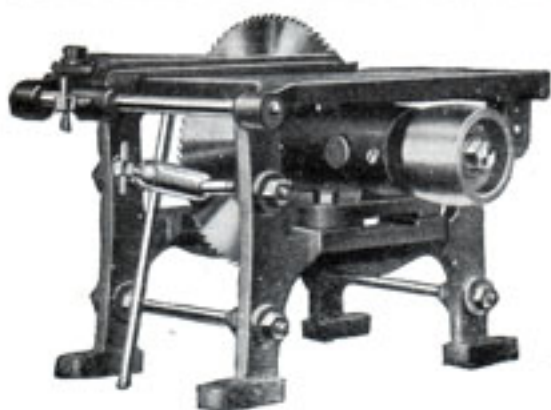

THE EMPIRE SAW BENCH No. 1316w.
RISE AND FALL TABLE.

This Saw Bench is a substantially built tool, rigid in construction, thus ensuring freedom from vibration. It is supplied with plain and mitre fences and is capable of dealing with the many small jobs which are found in all workshops.

These Machines will cut wood, brass, copper, lead, etc., and are made in the following sizes :

Size.	Size of Table.	Diameter of Saw.	Weight.	Price.
No. 1 ...	8 x 9 1/2 in.	6 1/2 in.	33 lb.	50/- each.
.. 2 ...	12 x 16 ..	8 ..	55 ..	87/- ..

PLANE AND MOULDING IRON GRINDER

No. 1317w.

This is a very useful Machine for grinding plane irons, shaped moulding cutters, chisels, gouges, etc.

The body is a strong box casting mounted on cast iron frame; the base is machined down both sides to carry the slide rails, so that these can be moved without having to be reset as in some machines. The slide moves on planed rails, and the plane irons are bolted to the swing bracket, which has a fine screw adjustment for canting, so that the plane irons can be ground to any required level.

Price for 26 in. Irons...	...	£21 : 0 : 0
.. 36	£22 : 10 : 0

R.p.m., 1,500 ; size of pulleys, 4 in.

Carriage Forward.

A Saw Gulleting apparatus may be fitted to this Grinder. See page 129.

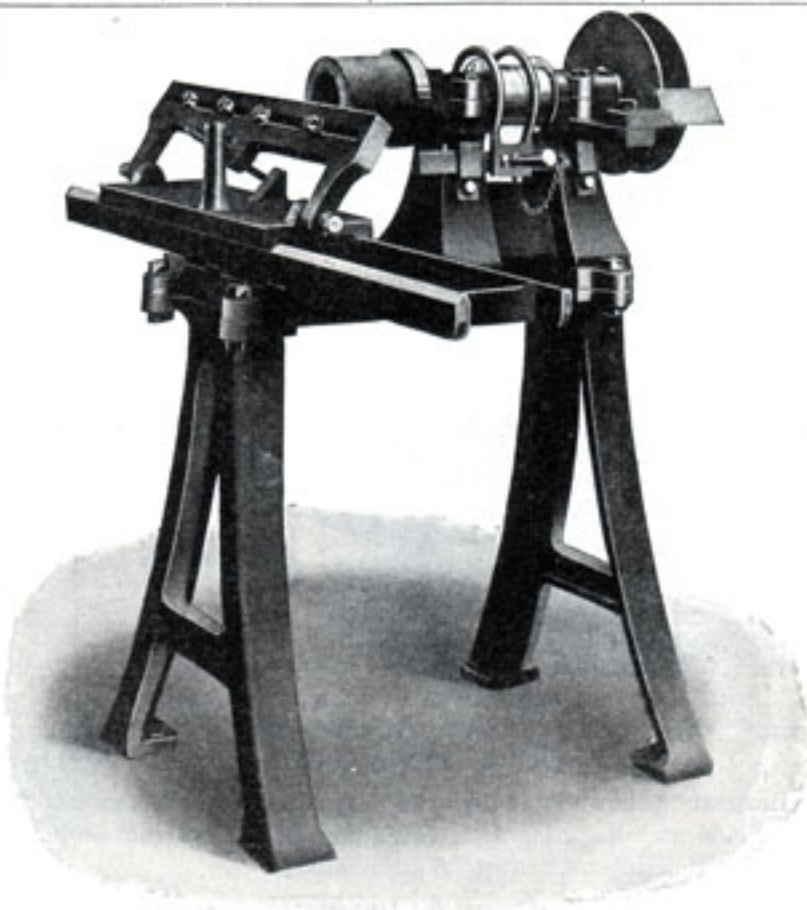

Bronze Medal 1884—Gold Medal 1890

TOOL AND MACHINE MERCHANTS

ELECTRIC TABLE BANDSAW

No. 1318W.

The "Liliput" is immediately ready for use in woodworkers' shops, also in the house; in short, anywhere where the necessary connection is available.

Indispensable for builders, model and furniture makers, piano and box makers, packing case, toy, or household ware manufacturers, cabinet or picture frame makers, shop fitters, lithographic block makers, etc.

IT CAN BE USED ON THE USUAL WORKSHOP OR LIGHTING CIRCUIT

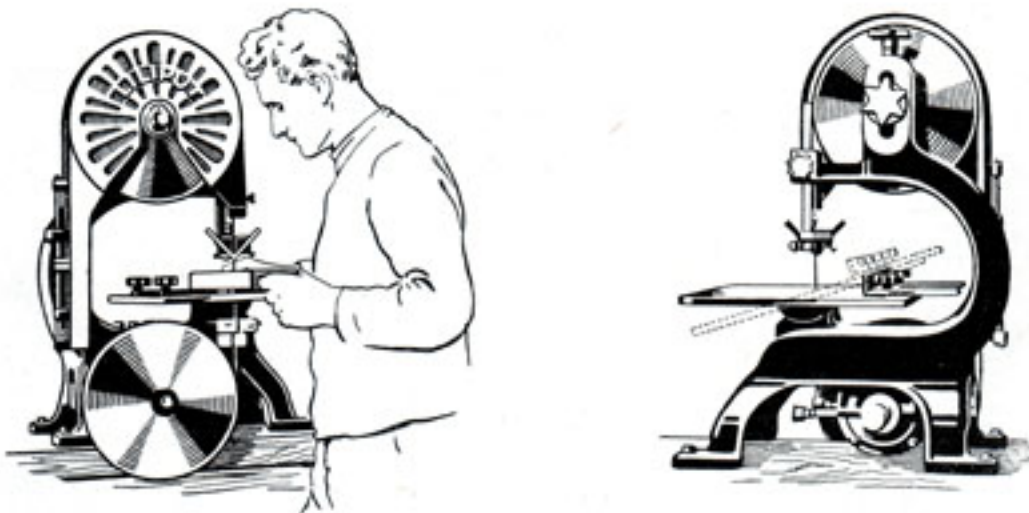

With self-contained dust-proof and enclosed patent economic motor, which may be considerably overloaded (2½-3-fold) without any intermediate drive whatsoever, without countershaft or belts, no loss of power. With attached high-tension starter, therefore extremely easy manipulation.

Saw table swivelling to 45° allows the cutting of sections. Adjustable side gauge on the saw table ensuring accurate working. Band guide with tension roll prevents any slipping of Bandsaw.

Height	33 $\frac{3}{16}$ in.
Width	22 $\frac{1}{4}$ "
Breadth	17 $\frac{3}{16}$ "
Diameter of Saw Wheels	12 "
Maximum length of Saw	82 "
Minimum " "	74 "
Normal width of Saw	$\frac{5}{16}$ "
Weight (complete with Motor), approximate	154 lb.
Admits in width	12 in.
" height	6 "

Operative security, the certainty of constant and efficient working without breakdown, are noteworthy features of the "Liliput." The tension on length of the Saw is adjustable through the medium of the top drum. Blades that have been shortened by 8 in. may still be used. Protecting guard on the top drive prevents any accidents.

The "Liliput" cuts all grades of wood up to 4½ in. in thickness, also hard rubber, fibre, bone, horn, ivory, cardboard, compressed paper, sheet metal, small metal castings, etc.

Price (complete with Motor, Cable, and Plug) £25 : 0 : 0

No. 1319W. Price, with Fast and Loose Pulleys, £21 : 0 : 0 (no Motor).

When ordering, please state whether A.C. or D.C. and voltage of your electric supply.

Carriage Forward.

Engineers' Tools and Machinery

BANDSAW MACHINES



No. 1320W.

These are specially made for small users. The saw wheels are accurately turned, balanced, and covered with rubber bands. The upper wheel is adjustable for various length saws. The table is truly planed and is fitted with a canting motion.

SIZES AND PRICES

Including Pulleys, Belt Shifter, and Saw.

Size of Table.	Diameter of Saw Pulley.	Maximum Depth of Cut.	Diameter of Driving Pulleys.	Revolutions per Minute.	Price.
16 x 16 in.	16 in.	5 in.	8 x 3 in.	450	£24 : 0 : 0

REX BANDSAWING MACHINE

No. 1321W.

This is supplied for either hand or power driving, or for both combined. Including one 1/2 in. wide saw blade.



No.	1	2
Saw pulleys ...	20 in. diam.	16 in. diam.
Depth of cut ...	11 in.	8 in.
Approximate H.P. ...	1 1/2	1
Net weight—cwt. ...	8 1/2	5 1/2
Gross weight—cwt. ...	10 1/2	7
Shipping space—cubic feet ...	55	50
Price ...	£31 : 10 : 0	£21 : 0 : 0

NEW PATTERN WITH 20 IN. WHEELS

No. 1322W.

This Machine has had such a phenomenal run that it has come to stay. With high-class ball bearings, and vulcanised and balanced rubber wheels, we have eliminated saw breaking to a minimum. It has a ball-bearing saw guide, tilting device, and canting table.

Wheel guards supplied at extra charge. Size of table, 22 x 18 in.; depth of cut, 8 in.; r.p.m., 500. Net weight, 3 1/2 cwt.; gross weight, 5 cwt. Price ... £26 : 10 : 0



COMBINED BAND AND CIRCULAR SAW

No. 1323W.

The table is 4 x 2 ft., and blades up to 15 in. diameter, to cut 5 in. deep, can be used. The spindle has rising and falling adjustment, and runs in adjustable parallel phosphor-bronze bearings. A self-acting rope feed is usually fitted and operated by a lever at the end of the bench. An adjustable canting fence is provided, and the following tools are supplied: One 15 in. and one 9 in. diameter circular saw-blade, one 1/2 in. wide bandsaw, screwkey, and, if with boring apparatus, one 1/2 in. auger.

Size of band pulleys, 18 in.; depth of cut, 6 in.; H.P. reqd., 1 1/2; weight, 12 cwt.

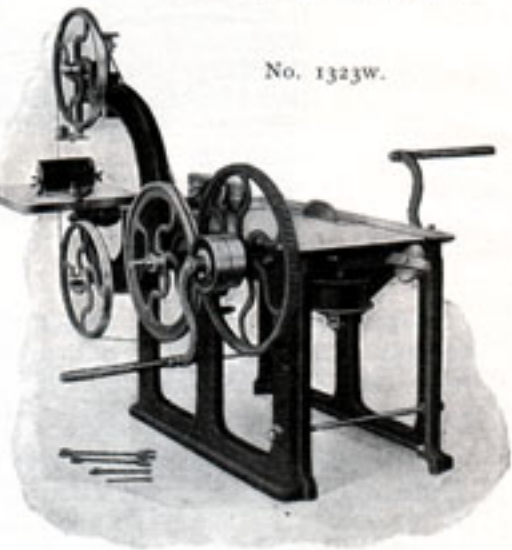

Price £60 : 10 : 0

Machines on this page Carriage Forward.

Builders' and Furnishing Ironmongery

HIGH-CLASS BANDSAW MACHINE

BALL BEARINGS.

No. 1324W.

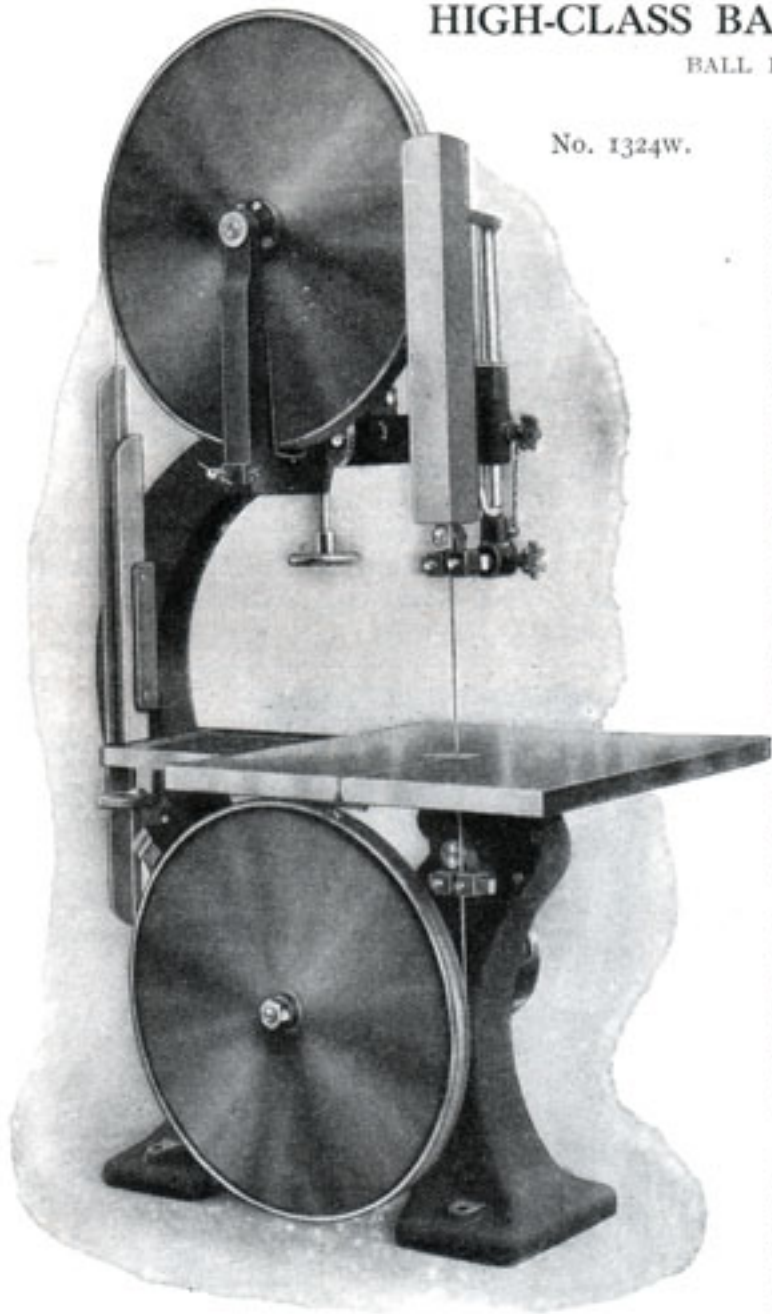

This new Model Band Sawing Machine is our latest pattern. It is a machine of the highest productive capacity, specially designed for the inclusion of ball bearings and other improvements; it is suitable for engineers, pattern makers, shipbuilders, cabinet makers, joiners, etc.

The Main Frame is a strong cored casting in one piece with ample base, securing strength and preventing vibration when working; the table is strongly ribbed, and is arranged with a canting motion so that the work can be cut to any required bevel. An extension table is fitted behind the canting table, which covers the bottom saw wheel and prevents pieces of wood dropping into it.

The Saw Wheels are both very accurately balanced, and move at the slightest touch; the rims are covered with a special material for preserving the set of the saw, which is firmly cemented on and will not perish. A brush is fixed to keep the bottom saw pulley clear of resin, dirt, etc.

Ball Bearings of the finest manufacture are fitted to the shafts of both saw wheels; these are mounted in dust-proof housings filled with grease; the top wheel is mounted in a box section "U" arm, which provides support on both sides of the wheel.

A Tilting Arrangement is fitted to the top wheel so that the saw may be made to track on any part of the face of the wheel; it is controlled by a screw motion, and can be adjusted while the saw is running. The improved tension motion is very sensitive, and compensates for expansion and contraction of saw while working; it can be strained to suit narrow or wide blades as required.

Our Improved Adjustable Saw Guides are fitted both above and below table. Both are of special anti-fractional pattern with ball thrust, in which the saw bears against the face of a steel disc, providing a broad support for the saw without generating heat; hardwood side pieces are provided so that the saws are not crystallised by contact with stationary metal.

Steel Disc Guards are fitted to both saw wheels, also wood side guards, as are required to comply with the latest Home Office Regulations, and no extra charge is made for these. Fast and Loose Pulleys and convenient belt motion, one $\frac{3}{8}$ in. Band Saw, and Spanner are included.

No.	Diam. of Saw Wheels.	Depth of Cut.	Diam. of Pulleys.	Size of Table.	Revs. per Min.	Price.	Shipping Particulars.		
							Gross Weight.	Cub. ft.	
1	30 in.	14 in.	12 in.	30 in. sq.	500	£45 : 0 : 0	1,500 lb.	56	
2	36 "	18 "	14 "	36 "	425	£65 : 0 : 0	2,056 "	75	
3	42 "	21 "	16 "	42 "	350	£85 : 0 : 0	3,550 "	140	
If fitted with Adjustable Straight Fence							...	£3 : 0 : 0	extra.
" " " Canting "							...	£6 : 10 : 0	"

Carriage Forward.

Horticultural and Estate Appliances

STRONG NAILED TOOL CHEST

No. 1325W.

With steel hinges, drop handles, and link plate lock. Each corner is protected and strengthened by strong iron plates. Two coats of wood preservative are applied inside and outside the chest. Size 32 in. long x 13 in. wide x 11 in. high.

Price, empty, **£1 : 10 : 0**. Price, complete with Tools as specified, **£7 : 15 : 0**.

Jack Plane, Smooth Plane, 3 Bradawls, 3 Gimlets, Pincers, Pliers, 6 Chisels, 2 Gouges, one 6 in. Square, Bevel, Rule, Compasses, Axe, Oilstone, Oil Can, Tin Liquid Glue and Brush, 2 Screwdrivers, Marking Gauge, Mallet, Hammer, Draw Knife, Spokeshave, Hand Drill, Brace, 6 Centre Bits, Screwdriver Bit, 2 Countersinks, 2 Punches, Marking Awl, 26 in. Hand Saw, 10 in. Tenon Saw, Saw Pad, Rasp, File, Scraper Blade, Level, Nails, etc., Cork-rubber, and Sandpaper.

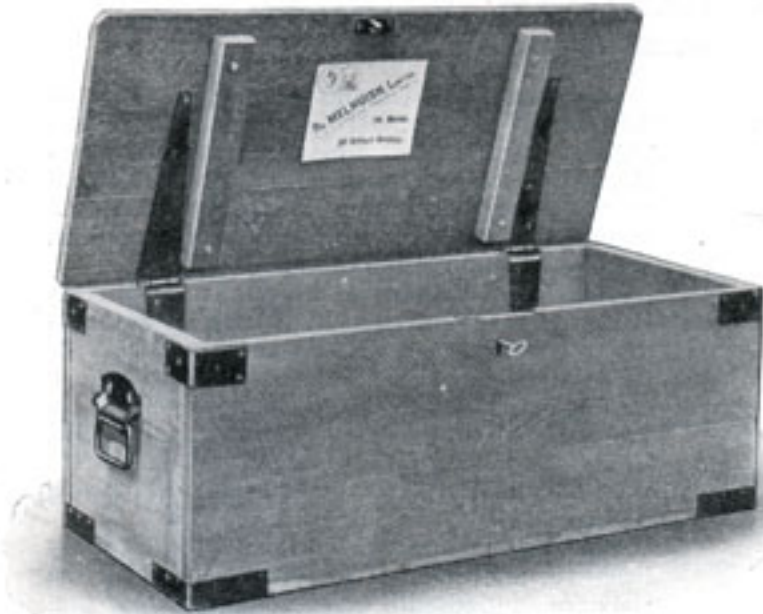

THE "HOUSEHOLD" TOOL CUPBOARD

No. 1326W.

Made of Solid Oak, waxed polished.

Price, complete with the following selected Tools.

£3 : 3 : 0

Mallet, Chisel, Gouge, Axe, 2 Hammers, Saw, 2 Files, 2 Screwdrivers, Square, Tack Lifter, Pliers, 2 Gimlets, 2 Bradawls, Pincers, Plane, Glue and Brush, Punch, Cold Chisel, Nails, and Screws.

Any of the Tools mentioned may be substituted for others of equal value.

Size, 25 in. high x 15 in. wide x 8 in. deep.



ALL BALL-BEARING BANDSAW

No. 1327W.

This Machine has been specially designed to meet the requirements of the wood-worker in general. It is fitted with ball bearings throughout.

This Machine is also supplied with geared treadle motion.

An electric motor (½ h.p.) can be fixed inside the stand, so making the Machine self-contained.

Dimensions: Size of wheels, leather covered, 14 in. diameter x 1 in. face; size of table (tilts to an angle of 45°), 16 x 18 in.; height of Machine, 3 ft. 6 in.; height of base, 24 in.; working height under guide, 6 in. Cuts soft wood up to 3 in. thick.

PRICES:

Complete Bandsaw, for power drive (as shown)	£11 : 5 : 0
" " treadle motion	£14 : 0 : 0
Bandsaw, without stand	£9 : 0 : 0



For Power Drive.

Carriage Forward.

Electric and Wireless Engineers

TOOL AND MACHINE MERCHANTS

SELECTED TOOL CHESTS

No. 1328W.

These are made very nicely and well finished, Hardwood being employed. Polished light colour, furnished with side hooks and eyes and japanned drop handles. Size $19\frac{1}{2} \times 8\frac{1}{2} \times 4\frac{1}{2}$ in.

Price, empty, 10/- each.

Price, complete with the following Tools from our own stock, £2 : 0 : 0

- | | | |
|---------------------------------|------------------|---------------|
| 4½ lb. Mallet. | Bradawl. | Tack Hammer. |
| Registered pattern Screwdriver. | Gimlet. | Pliers. |
| Hand Saw. | Hammer. | Plane. |
| 2 Chisels, ½ and ¾ in. | Oil Can. | Square. |
| Gouge, ¼ in. | Oilstone. | Pincers. |
| Tenon Saw. | Iron Spokeshave. | File. |
| | Rule. | Tube of Glue. |

A Smaller Box containing 14 Tools, 25/-



No. 1329W.

The same make of Chest as the one above, but with drawer as illustrated, and strong lock. Size $23 \times 10 \times 7\frac{1}{2}$ in.

Price, empty, 25/- each.

Price, complete with the following Tools, £4 : 0 : 0

- | | |
|--------------------|-----------------|
| Hand Saw. | Rule. |
| Tenon Saw. | 2 Screwdrivers. |
| Brace. | Oilstone. |
| 12 Bits, assorted. | Pincers. |
| Wood Plane. | Wood Rasp. |
| 4 Chisels. | File. |
| 2 Gouges. | 2 Brad Punches. |
| Spokeshave. | Hammer. |
| Mallet. | Marking Gauge. |
| 3 Bradawls. | Cork-rubber. |
| 3 Gimlets. | Saw File. |
| Square. | Spirit Level. |

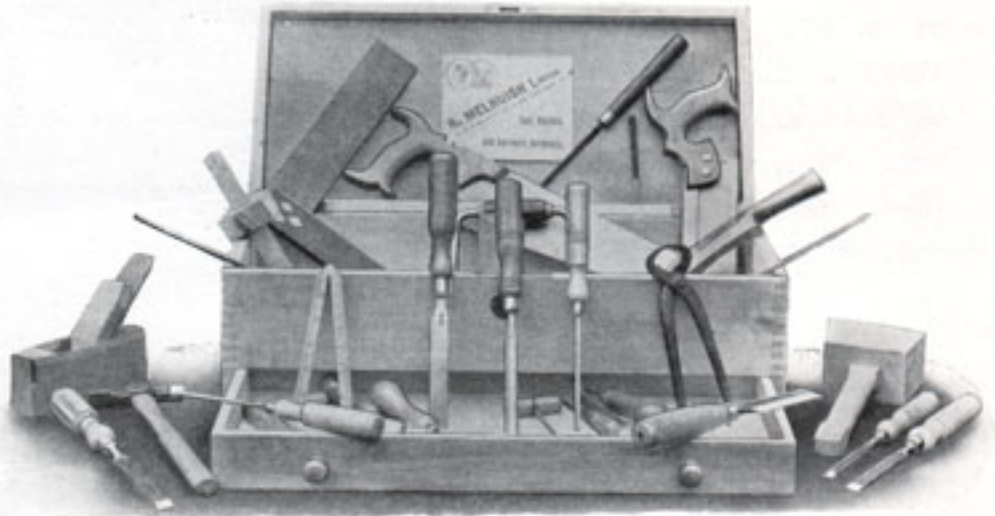

MELHUISS'S PRESENTATION TOOL CHEST

No. 1330W.

Best selected Oak, dovetailed corners. Polished and well finished throughout. Fitted with lock and heavy Brass plate handles, with drawer and cross tray inside. Made on our own premises. Size, 24 in. long \times 12 in. wide \times 10½ in. high (over body).

List of Tools :

- | | | |
|--------------|------------------|---------------------|
| 2 Best Saws. | Smoothing Plane. | Marking Gauge. |
| Axe. | Jack Plane. | Glue Pot and Brush. |
| 2 Hammers. | 6 Chisels. | Drawing Knife. |
| Mallet. | 4 Gouges. | Cutting Punch. |
| Rule. | 4 Files. | Scraper. |
| Pincers. | Oilstone. | Bevel. |
| 6 Gimlets. | Marking Awl. | Furniture, etc. |
| 6 Bradawls. | 2 Punches. | |
| Square. | 3 Turn-screws. | |
| Claw Wrench. | 2 Spoke-shaves. | |
| Pliers. | | |
| Compasses. | | |
| Lock Saw. | | |

Price, empty, £5 : 0 : 0 each.

Price, complete with warranted Tools as specified, £9 : 10 : 0

NOTE.—Clients are not in any way obliged to take all the tools as selected by our experts, but suggest the list is an excellent assortment for general requirements.—R. MELHUISS, Ltd.



Bronze Medal 1884—Gold Medal 1890

EMIGRANT'S TOOL CHEST

Made of Deal and painted Slate Colour.

With or without Tools.

No. 1331W.

32 in. long,
15 in. wide,
14 in. high.
With lock and
key and cross
tray. Price,
empty, 60/-
each.



No. 1332W.

36 in. long,
17 in. wide,
18 in. high.
With lock and
key and one
long tray. Price,
empty, 70/-
each.

CONTENTS

No. 1333W.

<p>1½ lb. Handled Axe. Handled Adze. 26 in. Hand Saw. 12 .. Tenon Saw. 14 .. Compass Saw. 2½ .. Jack Plane. 2½ .. Smoothing Plane. 1 .. Rebate Plane. 1 pair ½ in. Grooving Planes. ½ in. Bead Plane. ½, ¾, 1, 1½ in. Handled Firmer Chisels. 1, 1½, 1½ in. Handled Socket Chisels. ½, ¾, 1 in. Handled Mortise Chisels. ¼ and 1½ lb. Handled Hammers. 8 in. Tower Pincers. 6 .. Cutting Pliers. 8 .. Wing Compasses. 10 .. Coach Wrench. ½, 1, 1½, 1½ in. Handled Screw Augers. 5 and 8 in. London Screw- drivers.</p>	<p>3 in. Round Blade Screw- driver. 9 in. Rosewood Square. 7½ Bevel. 8 .. Handled Flat File. 7 .. Half-round File. 7 .. Round File. 8 .. Half-round Rasp. 4 and 6 in. Taper Saw Files. 3 in. Spokeshave. 10 .. Drawing Knife. Ratchet Brace and 30 Bits. 7 Gimlets. 6 Bradawls. 2 Flooring Awls. 5½ in. Mallet. Marking and Mortise Gauges. Marking Awl. 2 Nail Punches. Chalk Line and Reel. Glue Pot and Brush. 2 ft. two-fold Brass Rule. Stocked Oilstone. Oil Can. 4 lb. Bench Vice. 6 × ½ and 8 × ½ in. Cold Chisels.</p>
---	---

Price complete £16 : 10 : 0

CONTENTS

No. 1334W.

<p>2 lb. Handled Axe. Handled Adze. 26 in. Hand Saw. 12 .. Tenon Saw. 14 .. Compass Saw. 2½ .. Jack Plane. 2½ .. Smoothing Plane. 2½ .. Try Plane. 1 .. Skew Rebate Plane. ½ and ½ in. Bead Planes. Moving Fillister Plane. Plough Plane and 6 Irons. Set of 12 (½ to 1½ in.) Handled Firmer Chisels. Set of 6 (½ to 1½ in.) Handled Firmer Gouges. Set of 5 (½ to 1½ in.) Handled Socket Chisels. Set of 3 (½ to ½ in.) Handled Mortise Chisels. ¼ and 1½ lb. Handled Hammers. 8 in. Tower Pincers. 6½ .. Flat-nose Cutting Pliers. 6 .. Round-nose Pliers. 8 .. Wing Compasses. 10 .. Coach Wrench. ½, 1, 1½, 1½ in. Handled Screw Augers. 6 and 9 in. London Screw- drivers.</p>	<p>4 in. Round Blade Screw- driver. 9 in. Rosewood Bevel. 6 and 12 in. Rosewood Squares. 5 .. 8 .. Handled Flat Files. 8 in. Half-round File. 8 .. Round File. 8 .. Half-round Rasp. 4½ and 6 in. Saw Files. 2 .. 3½ .. Spokeshaves 10 in. Drawing Knife. Ratchet Brace and 36 Bits. 7 Gimlets. 7 Bradawls. 2 Flooring Awls. 6 in. Mallet. Marking and Mortise Gauges. .. Awl. 2 Nail Punches. Chalk Line and Reel. Glue Pot and Brush. 2 ft. two-fold Brass Rule. Stocked Oilstone. Oil Can. 4 lb. Bench Vice. 6 × ½ and 8 × ½ in. Cold Chisels. 12 in. Turning Saw Frame. Keyhole Saw and Pad. 66 ft. Measuring Tape in Case.</p>
---	---

Price complete £22 : 0 : 0

Engineers' Tools and Machinery

TOOL AND MACHINE MERCHANTS



BEST POLISHED TOOL CABINETS, IN SELECTED OAK No. 1335W.

Fitted with lock and key and 2 drawers. The top of Cabinet is hinged to facilitate the handling of tools in and out of the rack.

Size: Width, 16 in.; height, 27 in.; depth, 8½ in. (outside dimensions).

Contains 46 Tools.

C.S. Hand Saw	Iron Plane.
" Tenon Saw.	Cutting Pliers.
2 Hammers.	Compasses.
2 Turnscrews.	Marking Awl.
Plated Square.	Brad Punch.
Beech Spokeshave.	3 Gimlets.
Saw Pad and Saw.	3 Bradawls.
Brace and 6 Bits.	Hand Vice.
2 Handled Chisels.	Spirit Level.
2 " Gouges.	Coach Wrench.
3 " Files.	Handled Scraper.
Handled Rasp.	Rule.
Hatchet.	Cold Chisel.
Pincers.	Oilstone in Case.
Mallet.	Nails, Screws, etc.
Glue Pot and Brush.	

Price £9 : 0 : 0 complete.

PANELLED CABINET, IN POLISHED OAK No. 1336W.

Size: Width, 25 in.; height, 29 in.; depth, 8½ in. (outside dimensions).

It contains the following Tools, every one of which is warranted.

Rip Saw.
 Cross-cut Saw.
 Compass Saw.
 Hack Saw.
 Coping Saw.
 2 Planes.
 Spokeshave.
 Steel Hatchet.
 6 Chisels, Handled.
 Oil Whetstone.
 Oiler.
 Can of Glue.
 Ratchet and Brace
 3 Gimlet Bits.
 7 Auger "
 Countersink.
 Steer's Patent Expansive Bit.
 Square Rimer.
 Pair Cutting Nippers.
 " Flat-nose Pliers.
 " Gas Pliers.
 " Wing Dividers.
 Rule.
 Marking Gauge.
 Try Square.
 Plumb and Level.
 Hexagon Level.
 Screwdriver Bit.
 2 Screwdrivers.
 2 Files.
 Cabinet Scraper.
 Automatic Drill.
 Tool Holder with 10 Tools.
 Steel Nail Hammer.
 Cup Point Nail Set.
 Tack Hammer.



Price £14 : 10 : 0 complete.

These, with other pattern Cabinets, are made on our own premises by most experienced Cabinet Makers, and nothing but the very best materials are used.—RICHARD MELHUISE, Ltd.

Builders' and Furnishing Ironmongery

CHESTS OF DRAWERS AND WOOD BOXES

FOR NAILS, SCREWS, SMALL FITTINGS, Etc. Etc.

TOOL CABINET

No. 1337w.



With side locking arrangement.

Price, with 7 drawers, 30/- each.

CABINET No. 1338w.



With 10 graduated drawers.
Size, 14½ × 11½ × 11 in. Price 32/6 each.

No. 1339w.

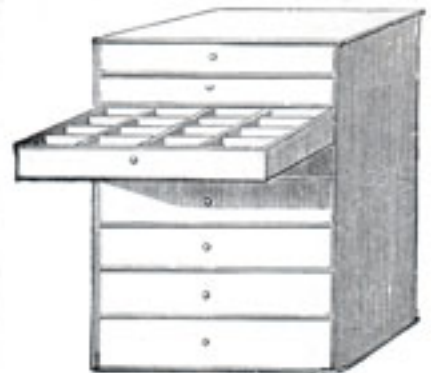

Size of chest, 17½ × 11½ × 11 in.
Price, with 8 drawers, 37/6 each.

No. 1340w.

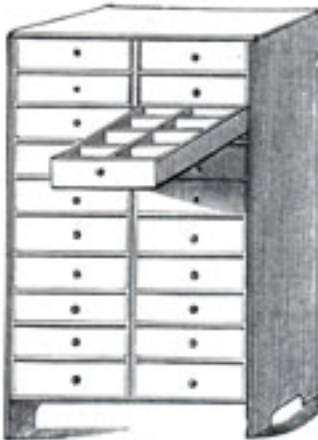

20 drawers.

Eight compartments in each drawer. Size, 23 × 12 × 7 in.
Price 25/- each.

CHEST OF DRAWERS

No. 1341w.



21 in. long, 12 in. high, and 11½ in. deep. Stained and polished Mahogany. The 5 top drawers contain in each 32 round metal boxes (160 in all), 2½ × ¼ in. deep, all with glass tops, thus enabling their contents to be seen at a glance without removing their covers, an advantage which is highly appreciated. The bottom drawer is empty, and is 3 in. deep.
Price 85/- complete.

WHITEWOOD CHESTS

No. 1342w.

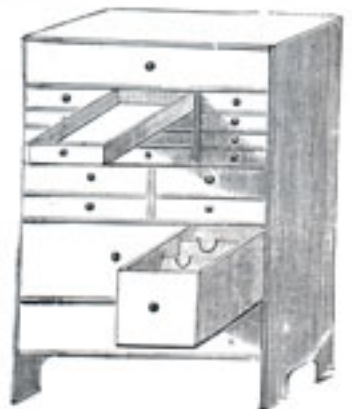

16 18 20 24 drawers.
Price 16/6 17/6 18/6 21/- each.

No. 1343w.



12 drawers.
Size, 29 × 7½ × 7½ in.
Price 39/6 each.

WHITEWOOD CHEST

No. 1344w.



20 drawers. Size, 23 × 12 × 7½ in.
Price 22/6 each.

SOLID OAK CHEST

No. 1345w.

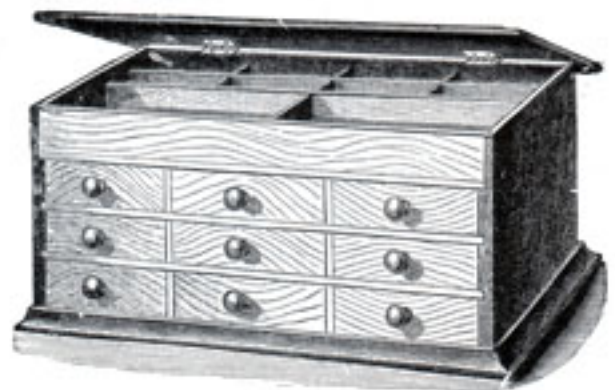

With 12 drawers. Size, 13 × 5 × 4 in.

Price 8/6 each.

TOOL AND MACHINE MERCHANTS

BOXES FOR SCREWS, NAILS, AND SMALL FITTINGS



No. 1346W. In Oak. 12 divisions.
Size $12 \times 3\frac{1}{2} \times 1\frac{1}{2}$ in. Size of divisions,
 $1\frac{1}{2} \times 1\frac{1}{2}$ in. ... Price 3/6 each.

No. 1347W

Whitewood. Nicely made. With Brass hinges and side books.

No. ...	1	2	3
Size ...	12×5	$15\frac{1}{2} \times 5$	21×7 in.
Divisions	18	24	20
Width of divisions	1	1	$1\frac{1}{2}$ in.
Price	4/-	5/-	9/- each.

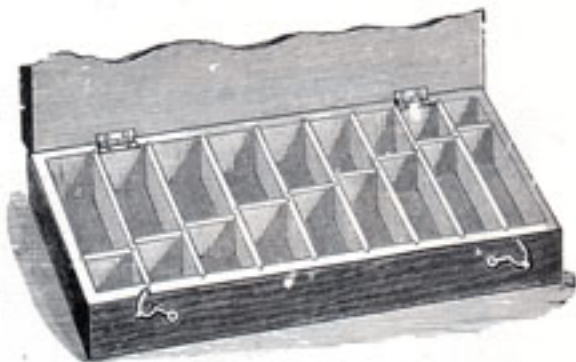

NAIL AND SCREW BOX

In Whitewood.

No. 1348W.

No. 1	2	3	
Size:	$10\frac{1}{2} \times 8 \times 2$	$13\frac{1}{2} \times 8 \times 2$	$15\frac{1}{2} \times 10\frac{1}{2} \times 2$ in.
Price	5/6	6/9	10/6 each.
Divisions:	12	15	24
Each division in all sizes is $2\frac{1}{2}$ in. sq.			

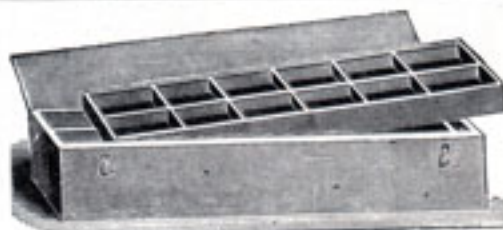

HARDWOOD SCREW BOX

No. 1349W.
 $11\frac{1}{2} \times 4\frac{1}{2} \times 2$ in. With trays. 24 divisions,
each one measuring $1\frac{1}{2}$ in. square. Price 5/- ea.

BEST SHELL GIMLETS

No. 1350W.
Box Handles.

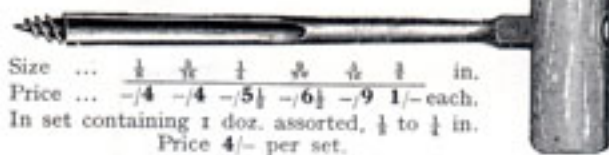

Size ... $\frac{1}{4}$ $\frac{5}{16}$ $\frac{1}{2}$ $\frac{3}{8}$ $\frac{7}{16}$ $\frac{1}{2}$ in.
Price ... -/4 -/4 -/5 $\frac{1}{2}$ -/6 $\frac{1}{2}$ -/9 1/- each.
In set containing 1 doz. assorted, $\frac{1}{4}$ to $\frac{1}{2}$ in.
Price 4/- per set.

BEST TWIST GIMLETS

No. 1351W.

Size ... $\frac{1}{4}$ $\frac{5}{16}$ $\frac{3}{8}$ $\frac{7}{16}$ $\frac{1}{2}$ in.
Price ... -/4 -/4 -/4 $\frac{1}{2}$ -/5 -/9 1/1 each.

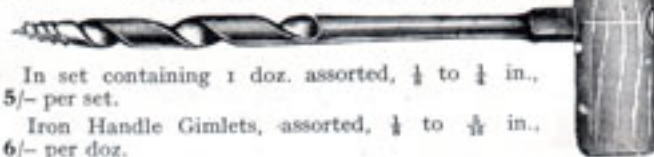

In set containing 1 doz. assorted, $\frac{1}{4}$ to $\frac{1}{2}$ in.,
5/- per set.
Iron Handle Gimlets, assorted, $\frac{1}{4}$ to $\frac{3}{8}$ in.,
6/- per doz.

AUGER GIMLETS

No. 1352W.
Box Handles.

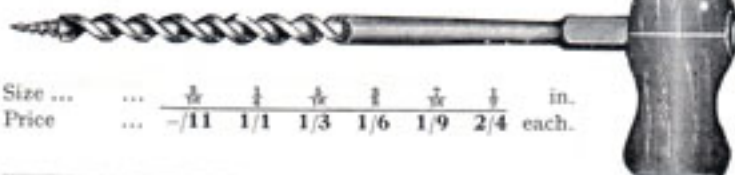

Size ... $\frac{5}{16}$ $\frac{1}{2}$ $\frac{3}{4}$ $\frac{7}{8}$ 1 $1\frac{1}{8}$ in.
Price ... -/11 1/1 1/3 1/6 1/9 2/4 each.

BREWERS' GIMLETS

No. 1353W.
Best Quality Twist.

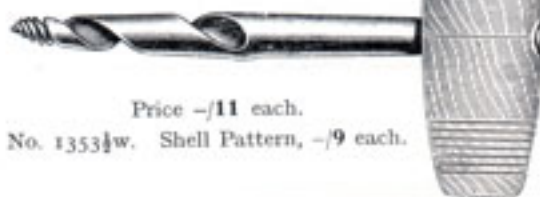

Price -/11 each.
No. 1353 $\frac{1}{2}$ W. Shell Pattern, -/9 each.

SWISS PATTERN

No. 1354W.
Box Handle.

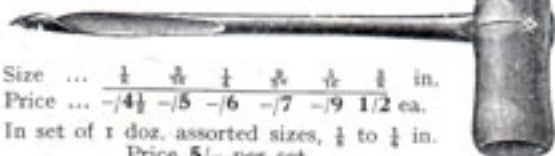

Size ... $\frac{1}{4}$ $\frac{5}{16}$ $\frac{3}{8}$ $\frac{7}{16}$ $\frac{1}{2}$ in.
Price ... -/4 $\frac{1}{2}$ -/5 -/6 -/7 -/9 1/2 ea.
In set of 1 doz. assorted sizes, $\frac{1}{4}$ to $\frac{1}{2}$ in.
Price 5/- per set.

SET OF TWELVE BRIGHT SWISS BITS

No. 1355W.

In Patent Adjustable Polished Handle.
The Bits may be used either as Gimlets or in Brace.
Price 4/6 per set.



BELL-HANGERS' GIMLETS

No. 1356W.



$12 \times \frac{1}{4}$ in., 1/-; $18 \times \frac{1}{4}$ in., 1/2; $24 \times \frac{3}{16}$ in., 1/10; $30 \times \frac{3}{16}$ in., 2/3; $36 \times \frac{1}{2}$ in., 3/3 each.

Electric and Wireless Engineers

NEW PATTERN WORK BENCH

OUR OWN DESIGN. SOLID BEECH TOP

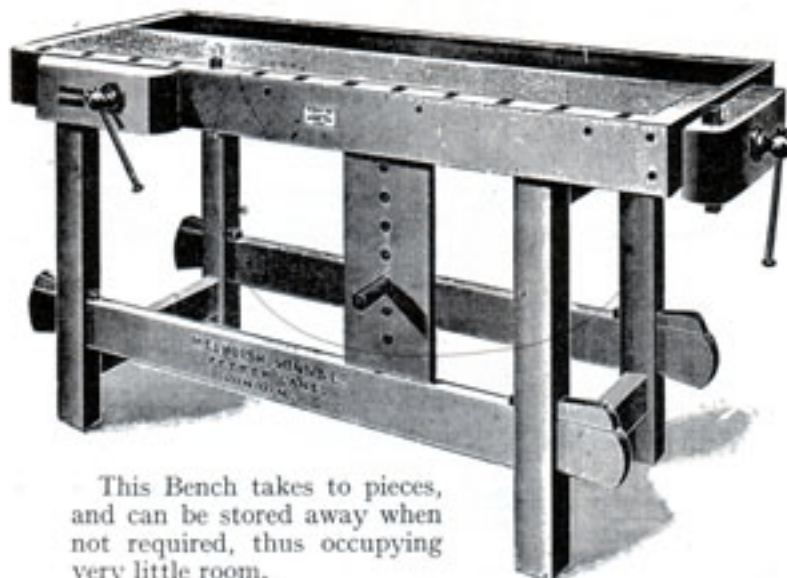

This Bench takes to pieces, and can be stored away when not required, thus occupying very little room.

No. 1357W.

This is furnished with two metal stops and two mild steel square thread bench screws. It has also a sliding rail for supporting heavy boards or planks whilst being planed.

Length, 5 ft. x 1 ft. 11 in. wide x 2 ft. 9 in. high.

Price £6 : 10 : 0

Length, 6 ft. x 1 ft. 11 in. wide x 2 ft. 9 in. high.

Price £7 : 10 : 0

If fitted with a 9 in. Instantaneous Grip Vice, No. 956W, 24/- extra. No charge for fitting.

WORK BENCH

No. 1358W.

This is made of selected Hardwood and is an admirable pattern in all ways. The solid top is 2½ in. thick x 18½ in. wide x 5 ft. long. The legs are 2½ in. thick and very firmly bolted together. They can be disconnected from bench quite easily and stored away when not required. The vice is a 9 in. instantaneous grip pattern, shown on page 93 of this Catalogue. Wood facing is now fitted to vice without extra charge.

Price complete, £5 : 10 : 0

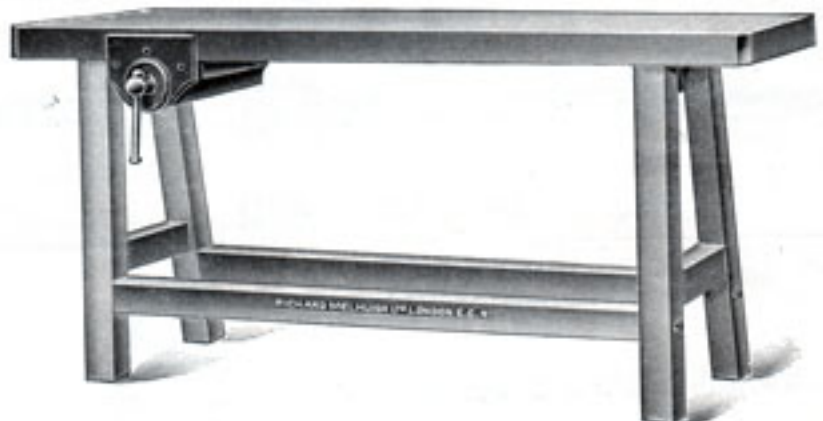

WORK BENCHES

No. 1359W.



Made from the finest solid Beechwood. Of heavy and substantial manufacture, and fitted with front and end vices with hardwood screws; also with a pair of iron bench stops. There is a well in the top, also a commodious drawer underneath.

Length, 5 ft.	£6 : 12 : 0
.. 6	£8 : 4 : 0
.. 7	£10 : 10 : 0

We can fit any Instantaneous Grip Vice to these Benches.

Prices and particulars of Technical Benches up to 12 ft. long sent on application.

All Benches are sent Carriage Forward except by Special Arrangement.

Bronze Medal 1884—Gold Medal 1890

MELHUISSH'S CABINET WORK BENCH



No. 1360W.

With Drawers and Cupboard, also Instantaneous Vice and Adjustable Stops for holding work.

The top is made from well-seasoned Beech, and the front is of Stained Mahogany and polished.

The Cupboard is fitted with a two-keyed Lever Lock. Also with shelf in centre.

5 ft. long, 20 in. wide, 36 in. high.

Price **£16 : 10 : 0** each.

6 ft. long, 20 in. wide, 36 in. high.

Price **£18 : 10 : 0** each.

N.B.—We can fit Lever Locks with Keys to the 5 Drawers, at an extra charge of 30/-
7 in. Vice, No. 957W, shown on page 93, is now fitted to Bench.

TECHNICAL PATTERN BENCH

No. 1361W.

Size, 5 ft. long, 2 ft. wide, 2 ft. 6 in. high.

Made of selected and well-seasoned Birch.

With 2 Wood Bench Screws.

Price **£4 : 15 : 0** each.

With 2 Iron Bench Screws.

Price **£5 : 10 : 0** each.

With two 7 in. Instantaneous Grip Vices, shown on page 93.

Price, **£6 : 10 : 0** each.

End Cupboards for taking students' tools may be fitted to Benches at an extra cost of 37/6 each Bench.

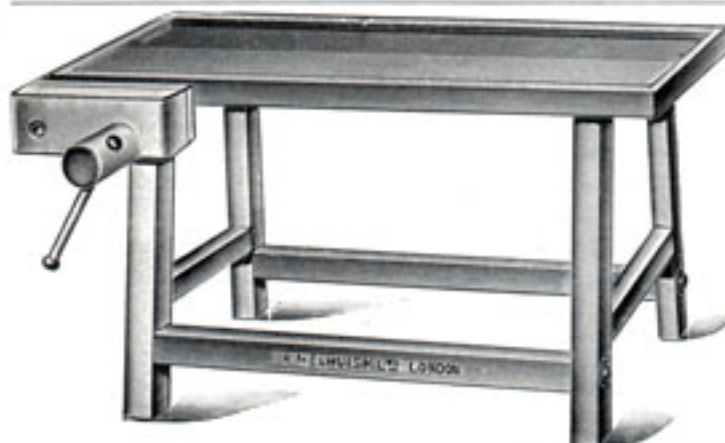

YOUTH'S WORK BENCH

No. 1362W.

Made of selected Hardwood, with Wooden Vice, as illustrated.

Length, 48 in.; width, 19½ in.; height, 32 in.; thickness of top, 2 in.

Price **£3 : 10 : 0** each.

The legs are rigid and fixed firmly to the top, but can be easily taken apart if necessary. Larger sizes of this Bench can be made, and we shall be pleased to quote you on receipt of all particulars.

All Benches Carriage Forward.

"THE WINDSOR" WORK BENCH TOOL CABINET

(RICHARD MELHUISE'S PATENT)

No. 1363W.

AWARDS
FOR EX-
CELLENCE
OF
TOOLS



BRONZE
MEDAL
1884

GOLD
MEDAL
1890

With deep cover and of the very best workmanship throughout.
Length, 4 ft. Width, 1 ft. 9 in. Height, 3 ft. 3 in.

The Tools sent out with this Cabinet are of Warranted Quality and as supplied to practical workmen.
Other selection of Tools than that given below can be supplied.

A large selection of these Cabinets is always on view in our Showrooms.

Price complete, in Selected Oak, £32 : 0 : 0. Price without Tools, £24 : 10 : 0 each.

List of Tools with which we usually furnish "The Windsor" Work Bench Tool Cabinet :

12 Carving Tools.	1 Cabinet Scraper.	1 Frame Bow Saw.	assorted Bright Boring Bits.
1 Duplex Iron Plane.	6 Assorted Firmer Chisels.	1 9 in. Tenon Saw.	1 Pair Pincers.
1 Straight Edge, 3 ft. 6 in.	3 " " Gouges.	1 2½ in. Jack Plane.	1 Spokeshave.
1 Bright Hammer.	1 6 in. Combination Square.	1 2 " Smoothing Plane.	1 Beechwood Gauge.
1 2 ft. two-fold Rule.	1 Boxed Oilstone.	1 Joiner's Hammer.	2 Rasps, handled.
3 Twist Gimlets.	1 Can Liquid Glue.	1 Melhuish's Hand Saw.	1 Pencil
3 Patent Bradawls.	1 Beech Mallet.	1 Box Drawing Knife.	1 Bright Bench Holdfast.
2 Screwdrivers.	1 " Mitre Block.	1 Brace, and set of 24 well-	

All Cabinets priced "Without Tools" are fitted with Patent Instantaneous Grip Vice. See page 93.

Empty Cabinets Carriage Forward.

Builders' and Furnishing Ironmongery

MELHUIH'S WORK BENCH TOOL CABINET

The
"EXONIAN"

No. 1364W.
Melhuish's Patent
Combined Wood
Carving and Joiner's
Work Bench and
Tool Cabinet.

Of the
HIGHEST
EXCELLENCE
in Material, Design,
Construction,
Finish, Simplicity,
Ease of Working,
Utility, and
Durability.



Made on our
premises by
experienced
Cabinet
Makers,
and highly
polished.

Length,
4 ft.

Width,
1 ft. 9 in.

Height,
3 ft. 3 in.

Illustration shows Cabinet in position for work, with the lid firmly supported by means of two Patent Flush Bolts. Top, cupboards, and all drawers can be instantly closed up and locked with one lock and key only. Price, in selected Oak, complete with Tools as specified, £45 : 10 : 0. Cabinet empty, £30 : 10 : 0 each.

- 12 Addis' Famous Carving Tools, fancy pattern handles.
- 9 Firmer Chisels, ditto.
- 3 Bradawls.
- 3 Gimlets.
- 1 Screwdriver, boxwood handle.
- 1 Small Cabinet Screwdriver.
- 1 Sliding Bevel.
- 1 3 in. Try Square.
- 1 10 1/2 in. Combination Square.
- 1 Straight Edge.
- 1 2 ft. two-fold Boxwood Rule.
- 1 Nickel-plated Brace and 24 Bright Bits
- 1 Hand Drill.
- 1 16 in. Hand Saw.
- 1 12 in. Brass Back Tenon Saw.
- 1 Dovetail Saw.
- 1 Turning Saw.
- 1 Compass Saw.

- 1 Adze Eye Claw Hammer.
- 1 Joiner's Hammer.
- 1 Mitre Block.
- 1 Iron-bound Mallet.
- 1 Combination Marking and Mortising Gauge.
- 1 Cutting Gauge.
- 1 Draw Knife.
- 1 pair of Pincers.
- 1 Large Cabinet Turncrew.
- 1 Jack Plane.
- 1 Try Plane.
- 1 Smooth Plane.
- 1 Adjustable Plane.
- 2 Truing Sticks.
- 6 Goggles, handled.
- 3 Mortise Chisels.
- 1 File for Metal.
- 1 " Wood.

- 1 Rasp for Wood.
 - 1 pair Tinman's Snips.
 - 1 " Flat Nose Pliers.
 - 1 " Round Nose Pliers.
 - 1 " Combination Pliers.
 - 1 Adjustable Spokeshave.
 - 1 pair of Compasses.
 - 1 Copper Glue Pot.
 - 1 Brush and Glue.
 - 1 Scraper Blade.
 - 1 Oilstone in Case.
 - 1 Slipstone.
 - 1 Oilcan.
- The Drawer with 20 divisions fitted with a large variety of Ironmongery, Screw Hooks, Screw Eyes, Nails, Pins, Screws, etc., well selected from our extensive stock, so very useful to the amateur workman.

N.B.—All our Cabinets are fitted with PATENT INSTANTANEOUS GRIP VICE, No. 957W, as shown on page 93; also RISING BENCH STOP and 3 ft. STRAIGHT EDGE.

SPECIAL NOTE.—It will perhaps occur to some intending purchaser, while perusing this section of our Tool Chests and Cabinets, that the lists of Tools with which we furnish these articles could be considerably augmented, in some details at least, without additional cost. To this we would reply that, while giving due and careful attention to the various and special needs of those for whom these Tool Chests and Cabinets are intended, our first consideration is QUALITY, and not quantity.

All Empty Cabinets Carriage Forward.

**IMPROVED PATENT COMBINED MORTISING, BORING,
AND TENONING MACHINE**

No. 1365w.

Will Mortise 11 in.; length of stroke, 6 in.; takes in work 12 x 5½ in.; approximate weight of Machine, 3½ cwt.

In this Machine the motion from the lever is communicated to the chisel through the centre of the slide, thereby giving a direct action over the chisel, and by this simple and effective arrangement, additional power is obtained.

All the working parts are accurately fitted and the chisels made to reverse true.

In fixing the chisel in spindle set the face of chisel square with the fence of the tray, and let the figures on the chisel be towards the handle that turns the chisel, and, in mortising, the face of the chisel must meet the cut.

The chisels are easily loosened in the spindle, by being partly turned with the screw key sent with the Machine. If the chisels are strained in working, and do not reverse true, they are easily made to turn true by being struck with a piece of lead, or a smart blow with a hammer.

Price, including 6 Best Cast Steel Chisels, 1 Core Driver, 1 Set Square, and 1 Spanner, **£14 : 10 : 0.**

Extra for Boring Apparatus, complete with ½, ⅝, ¾ in. Round-nosed Augers, and ¼, ⅜ in. Cast Steel Drills, **£2 : 5 : 6.**

Extra for Tenoning Tool, which will cut tenons from ½ to 1 in., **£2 : 16 : 6.**

Extra if fitted with Self-coring Chisels, instead of ordinary Chisels and Core Driver, **£1 : 5 : 0.**

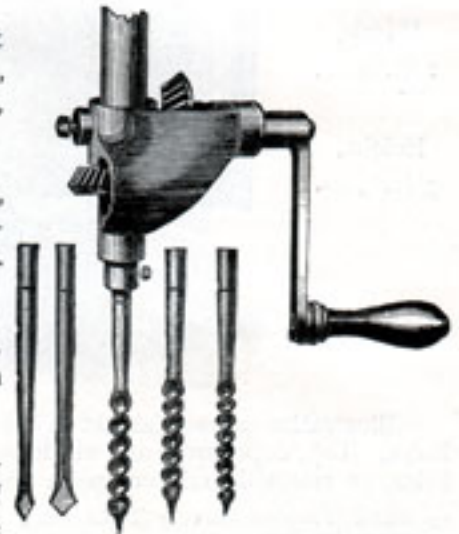

BORING APPARATUS

NEW PATTERN LEVER FLOOR CRAMP

No. 1366w.

WITH QUICK RELEASE.

Best Cast Iron frame, Malleable parts, and Wrought Iron lever.

To release, pull lever back, press foot on tails of front paws, and the ram will be pulled back by the spring.

Keep ram well oiled underneath.

To suit joists 1½ to 4 in. Approximate weight, 24 lb.

Price 19/- each.

Goods on this page Carriage Forward.



Electric and Wireless Engineers

PATENT CENTRE MOTION MORTISING MACHINE

No. 1367w.

Takes in wood 11 in. deep, 5½ in. wide.

Approximate weight, 3 cwt. 2 qr.

Shipping particulars.—Gross weight, 450 lb.; 23 cubic feet.

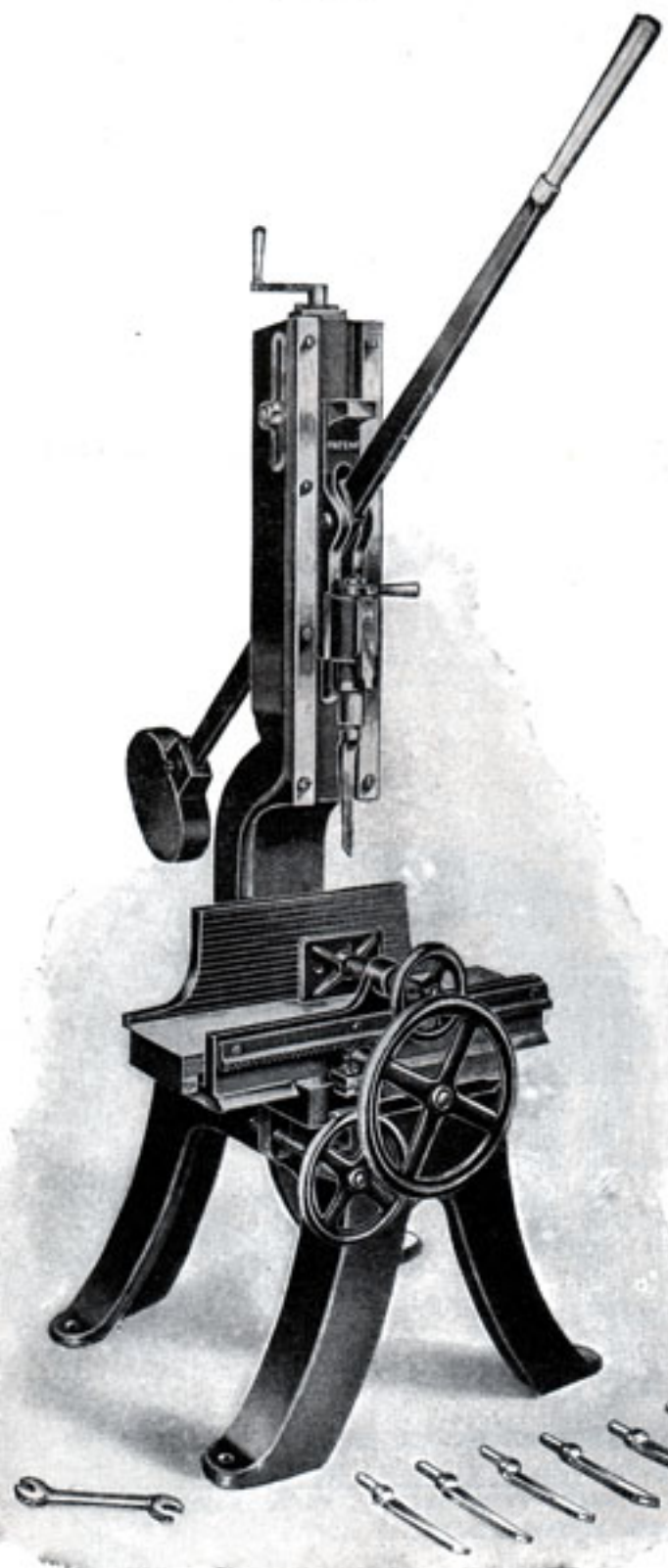

In this Centre Motion Machine there are no gears. The wrought iron lever passes through the centre of the chisel slide, and, therefore, when mortising, all the power is directly over the cutting edge of the chisel; there is no lost motion, and large additional power is obtained.

The Machine illustrated is the popular No. 2 Machine. It is in great demand for the usual work of joiners and builders, and many thousands are in use.

Particular attention may be called to the handle and top screw motion for instantly adjusting the stroke to the exact depth of mortise required. This is the only method which sets exactly for "blind" mortises without packing up the wood. The table has compound movements. All working parts have adjustment for taking up wear.

Special care is paid to accurate reversing; each machine is carefully tested and a record kept of its work.

Price, including 6 best C.S. Solid Chisels, ⅜, ½, ⅝, ¾, 1, 1½ in., 2 Core Drifters, and Spanner ... **£15 : 10 : 0**

Price if with best quality Self-coring Chisels, sizes as above, no Core Drifter, **£16 : 10 : 0**



Boring Attachment. Tenon Tool.

No. 1368w.

Boring Apparatus with 3 Augers and 2 Drills, price **£2 : 10 : 0 extra.**

No. 1369w.

Tenoning Tool, price **£2 : 15 : 0 extra.**

CARRIAGE FORWARD

Bronze Medal 1884—Gold Medal 1890

PATENT CHAIN MORTISING MACHINE

No. 1370W.



This Machine will admit timber 12 in. deep \times 7 in. wide, and cut mortises from $\frac{1}{4}$ to 1 in. wide \times $\frac{3}{4}$ to 3 in. long, and from $4\frac{1}{2}$ to 6 in. deep, at one stroke. Each Machine is supplied complete with one $\frac{1}{2}$ \times 2 in. chain, guide-bar, and sprocket, also improved chain cutter guard.

It can be supplied with hollow chisel mortising attachment for holes up to 1 in. square.

Prices on application.

Weight of Machine, 6 cwt. net. 8 cwt. gross.

H.P. required, 2-3.

Shipping space, 35 cub. ft.

Price, without Square Chisel Attachment.

£40 : 0 : 0

If with Ball Bearings.

£50 : 0 : 0



No. 1371W.

CABINET MAKER'S MACHINE

This will take wood 6 \times 3 in., and mortise 6 in. deep. Complete, with one chisel each $\frac{1}{4}$, $\frac{5}{16}$, and $\frac{3}{8}$ in. Core drifter and screwkey.

Price **£12 : 15 : 0**

If with Self-coring Chisels,

£13 : 15 : 0

CHALLENGE MORTISER

No. 1372W.

20,000 of these Machines have been sold to builders, contractors, and joiners. It is an excellent tool and thoroughly recommended.

The Machine will admit timber up to 16 in. deep \times 7 in. wide, and work mortises up to 1 in. wide \times 6 in. deep.

The main frame is of heavy construction, truly machined to receive the working parts.

The table has compound adjustments, by hand wheel and screw, and is fitted with clamp for securing the timber whilst being mortised.

Our Improved Tool Box is arranged to reverse the chisel, and can be adjusted on the back slide to suit different depths of timber. The black slide is operated by handle, rack, and quadrant.

Six plain chisels $\frac{1}{4}$ to $\frac{3}{4}$ in., one core driver, and spanner are included.

A Boring Apparatus, complete with three boring bits, $\frac{1}{2}$, $\frac{1}{4}$, and $\frac{3}{8}$ in. diameter, also self-coring chisels, can be supplied. Also a hub mortising attachment with dividing plate.

Price with ordinary Chisels	£19 : 8 : 6
.. .. Self-coring Chisels	£20 : 10 : 0
.. .. of Boring Attachment only	£3 : 5 : 0



IMPORTANT TO THOSE ORDERING THROUGH SHIPPERS.—In order to ensure getting complete satisfaction, we advise our friends to be careful in giving definite instruction that the goods shall be procured direct from our house. By this means you may be sure of receiving the pattern and quality specified in our

Catalogue.—RD. MELHUISH, Ltd.

Machines on this page Carriage Forward.

TOOL AND MACHINE MERCHANTS

No. 1373W.

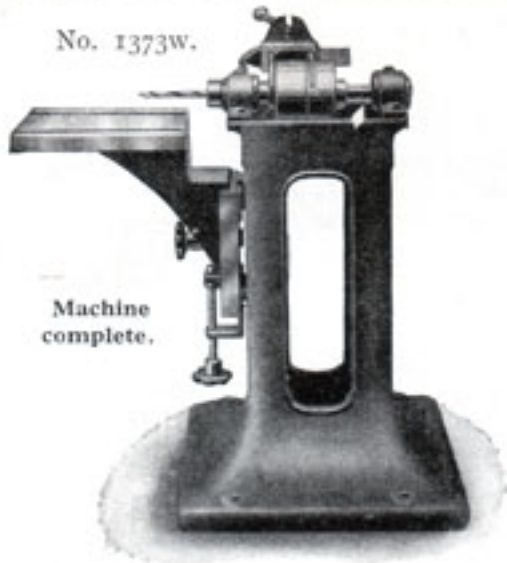

Machine complete.

BORING MACHINE

This Machine is designed to meet the need for a small horizontal wood borer, with rise and fall table.

The spindle runs in ball bearings and is bored for $\frac{1}{2}$ in. diameter shanks. Chuck can be fitted at an extra cost.

The Boring Table can be supplied separately, as illustrated, for customer to fix to existing machine, and will be found a very useful accessory.

Machine complete ... price £16 : 10 : 0

Boring Table only £7 : 5 : 0

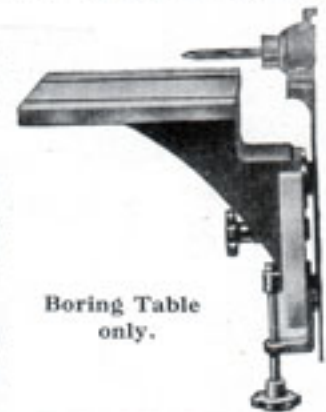

Boring Table only.

This has been designed to meet a long-felt want in trades where flat grinding surfaces are needed, such as engineers', brass finishers', woodworkers', bone and ivory workers'.

ADVANTAGES

It grinds to a straight finish, and no circular lines are left in the work as are in work from disc grinding. The surface speed is uniform, and does not vary from centre outwards, as in a disc grinder.

Bands.—One band in Emery or Sandpaper is supplied with each Machine. We can supply further bands in all grades with paper or cloth backs from stock.

Size of Band.	Size of Pulleys.	Speed.	Weight.
4 in. wide	6 x 1 1/2 in.	1,200 r.p.m.	56 lb.
Price	£4 : 15 : 0	

Extra Bands, Sand or Emery, 16/- per doz.

SANDING MACHINES

No. 1374W.

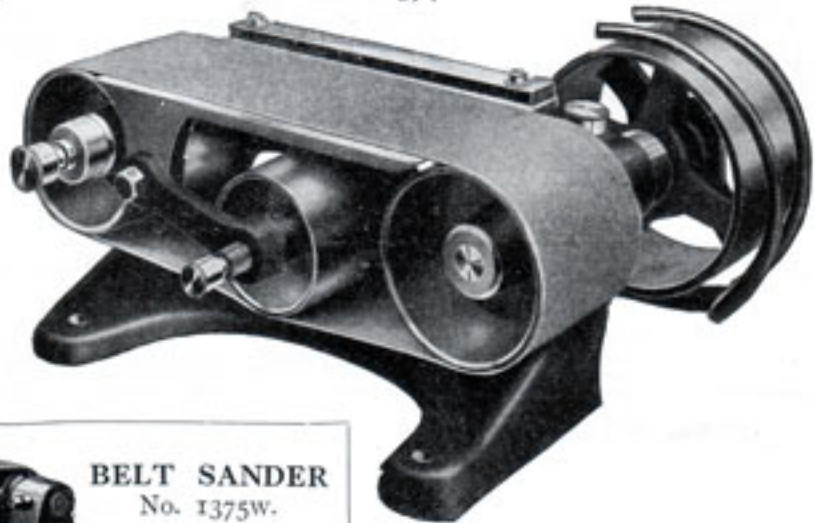

BELT SANDER

No. 1375W.

This Machine is designed to meet the need of a high-class Belt Sander of substantial design.

The large drum is 6 in. diameter, and the small one 3 x 8 in. wide, thus enabling small radius work to be sanded. The sandpaper belt is 6 ft. 2 in. for No. 1 and 9 ft. 2 in. for No. 2 long x 8 in. wide, and can be replaced in a few seconds without removing any part of the Machine. The distance between the centres of the spindles is 2 ft. 7 in. for No. 1 and 4 ft. 1 in. for No. 2. The table is iron and provided with a canting stop fence.

An efficient adjustable belt shifter is provided to allow for drive from various positions.

Price for Machine :

No. 1.	To fix to bench	£13 : 5 : 0
.. 1.	On stand as illustrated	£15 : 0 : 0
.. 2.	To fix to bench	£22 : 15 : 0
.. 2.	On stand as illustrated	£24 : 10 : 0

Size of pulleys, 7 x 2 in. ; speed, 600 r.p.m.

No. 1. Shipping weight, 2 1/2 cwt. Shipping measurements, 9 cub. ft.

No. 2. Shipping weight, 3 1/2 cwt. Shipping measurements, 11 cub. ft.

Price of band is only, in Sandpaper, 43/- and 72/6 respectively per doz.

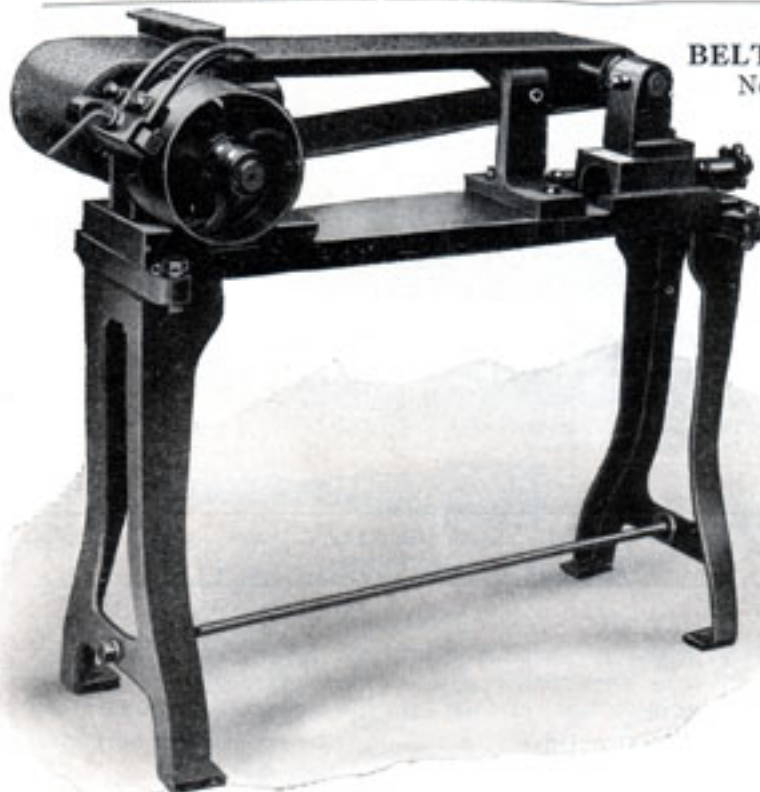

Builders' and Furnishing Ironmongery

RICHARD MELHUISE LIMITED, LONDON, E.C.

PLANING, THICKNESSING, MOULDING, AND SAWING MACHINES

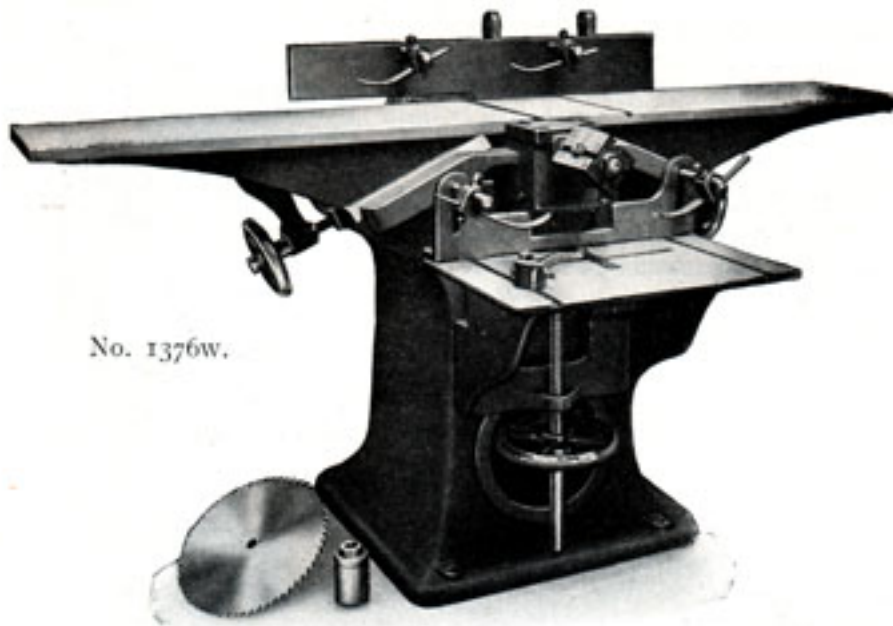

No. 1376w.

These **PLANER TABLES** have independent rise and fall movement, and are 6 ft. long overall, and fitted with steel lips. A long substantial fence is adjustable over full width of table, and arranged to cant for beveling, etc.

The Pedestal is a heavy cored casting built to withstand vibration. It is also fitted with an improved Safety Circular Type made from special forged steel and carefully balanced.

THICKNESSING AND MOULDING TABLE rises and falls in machined slides by hand wheel and screw, and the timber is held to the $4\frac{1}{2}$ in. wide cutter block by pressure springs. The table will rise above centre of spindle so that cutter block can be used underneath if necessary. Circular saw 12 in. diameter is also supplied, thus converting the Machine into a useful saw bench with rise and fall table.

No.	To plane	To thickness	Net Weight.	Gross Weight.	Shipping Space.	Speed of C/s.	Price.
No. 1	12 in.	$4\frac{1}{2}$ in.	10 cwt.	13 cwt.	30 c.f.	650	£58 : 0 : 0
" 2	15 "	$4\frac{1}{2}$ "	11 "	14 "	35 "	600	£71 : 0 : 0
" 3	18 "	5 "	13 "	17 "	39 "	570	£82 : 0 : 0

Countershaft can be had either with ring oiling or ball bearings, £7 : 10 : 0 extra.

This Machine has been greatly improved, and is as rigid as any machine upon stand.

The Tables are longer than is generally fitted to Bench Machines, and raise and lower by screw and hand wheel, with locking device to prevent tables moving when in work, and are planed on the edge to allow for rebating $\frac{1}{2}$ in. deep.

Steel Lips are fitted against the cutter block.

The Circular Cutter Block is 4 in. diameter, made from steel forging.

The Fence is long and of substantial design, and cants for angle work and is adjustable across the table.

A HIGH-CLASS MACHINE FOR BENCH OR STAND

No. 1377w.



No.	Length of Cutter.	Length of Tables.	Net Weight.	Gross Shipping Weight.	Cubic Shipping Measurements.	Price.
1	6 in.	3 ft. 0 in.	$1\frac{1}{2}$ cwt.	2 cwt.	5 cubic ft.	£ 19 : 0 : 0
2	9 "	4 " 0 "	2 "	$2\frac{1}{2}$ "	$6\frac{1}{2}$ " "	21 : 10 : 0
3	12 "	5 " 6 "	$3\frac{1}{2}$ "	4 "	8 " "	24 : 0 : 0
2a	9 in. on stand	4 " 0 "	$3\frac{1}{2}$ "	5 "	26 " "	28 : 0 : 0
3a	12 " " "	5 " 6 "	5 "	$6\frac{1}{2}$ "	28 " "	32 : 0 : 0

Countershaft £5 : 10 : 0 extra.

All Machines sent Carriage Forward.

Horticultural and Estate Appliances

TOOL AND MACHINE MERCHANTS

BASKET MAKERS' TOOLS

No. 1383w.

No. 1378w. No. 1379w. No. 1380w. No. 1381w. No. 1382w.
 No. 1384w.

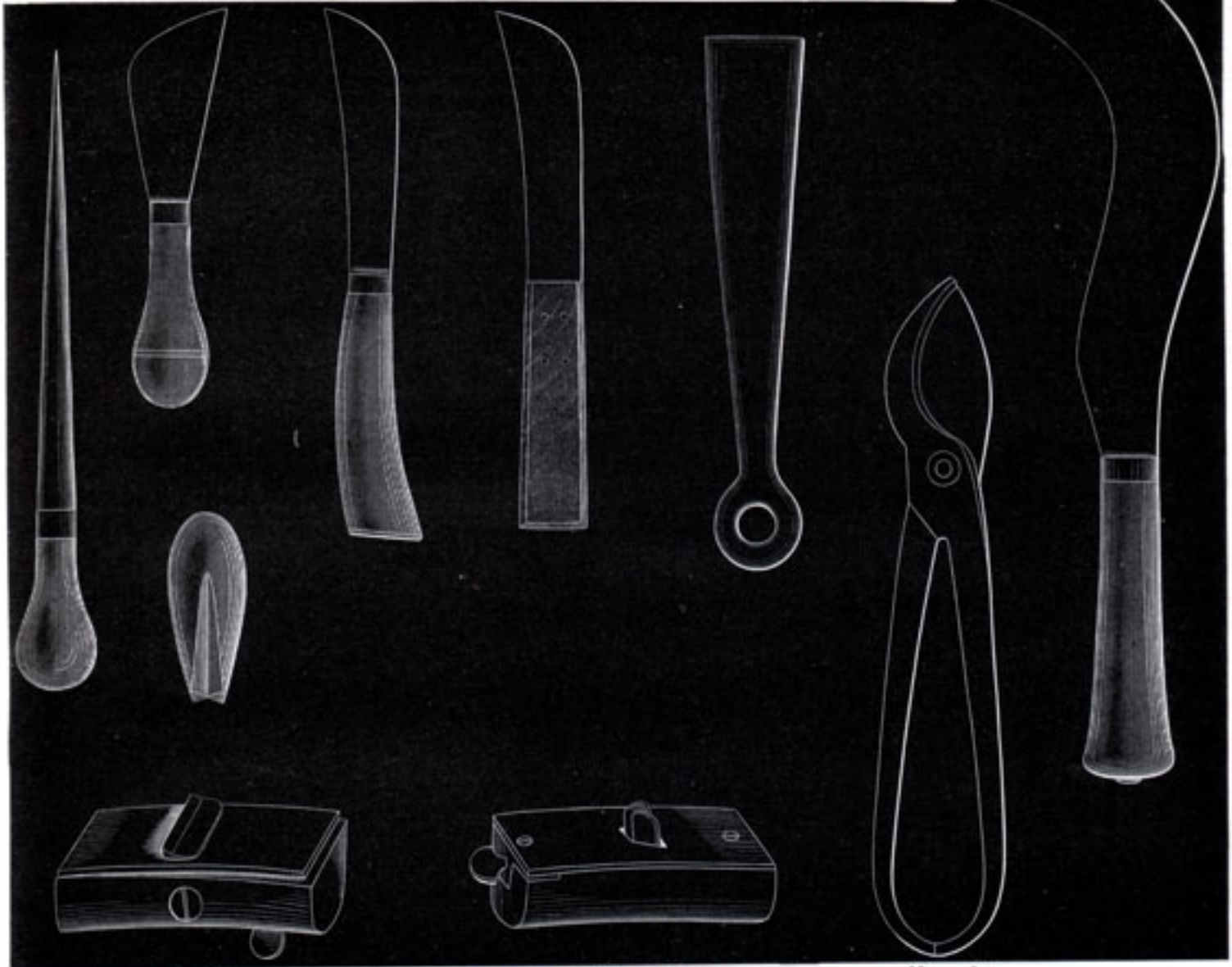

No. 1385w.

No. 1386w.

No. 1387w.

No. 1378w. Solid Bodkin, 4 in., 1/-; 5 in., 1/4; 6 in., 1/6; 7 in., 1/10; 8 in., 2/3; 9 in., 2/8; 10 in., 3/2 each. No. 1379w. Picking Knife, 1/2 each. No. 1380w. Shop or Hand Knife, 4 1/2 in., 1/1; 5 in., 1/2 each. No. 1385w. Shave, Steel Bed, 14/- each. No. 1386w. Upright, 14/- each. No. 1382w. Maul, 4/- each. No. 1387w. Shears, 10 in., 7/3; 11 in., 8/3; 12 in., 9/3; 14 in., 11/- each. No. 1384w. Cleaver, 1/3 each. No. 1383w. Willow Knife, 6/6 each. No. 1381w. Hand Knife, Tanged, 5 in., 2/3; 6 in., 3/- each.

TYPE FOUNDERS' CHISELS



No. 1388w. Price per set of 8 different widths in Beech handles, 8/6; 1/1 each
 No. 1389w. Runner Chisels, widths 1/2 in. 1 6, 3/4 in. 1 9, 7/8 in. 2/-, 1 in. 2 3 each.

BALL-BEARING SAW BENCH

No. 1390w.

This Bench is of very rigid build and will be found most useful. The top is canting, and has sliding fence as shown. The ball-bearing spindle will take a 12 in. saw, and has fast and loose pulleys.

Size of Table, 22 x 20 in.

Price complete £8 : 10 : 0

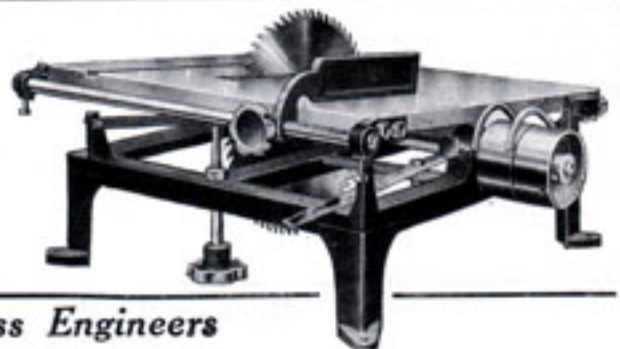

Electric and Wireless Engineers

RICHARD MELHUISH LIMITED, LONDON, E.C.

MELHUISH'S TREADLE LATHE FOR WOOD OR METAL

No. #1391W.

5 and 6 in. Centres.

THE FAST HEAD is supplied with three-step cone for round or flat belt. The spindle revolves in a conical brass bearing at the front, the end thrust being taken on a hardened adjustable steel centre. A driving plate is fitted to the spindle nose. Back gears can be fitted and are thrown out by lever and eccentric motion. The locking pin for cone and spindle wheel is operated by the fingers only.

THE LOOSE HEAD fits between the shears, and is secured by plate and bolt with nut as shown. The spindle is adjustable by hand wheel, and locked by nipping screw.

THE SADDLE AND COMPOUND REST, when fitted, is secured to the bed by two bolts and holding-down plate. The swivel slide can be revolved completely round, and the tool adjusted for height. Adjustable strips are provided to take up wear. The tool holder on top slide is arranged to take $\frac{1}{2}$ in. diameter boring bars.

THE HAND REST is adjustable and is provided with tees for wood and metal turning.

THE BED, which is fitted with back board full length, can be supplied with or without gap.

THE TREADLE MOTION shaft revolves on hardened centres, and carries cone for round or flat belt. The connection from treadle lever and runner is by chain. Two ordinary centres, and one fork centre for wood, are supplied.

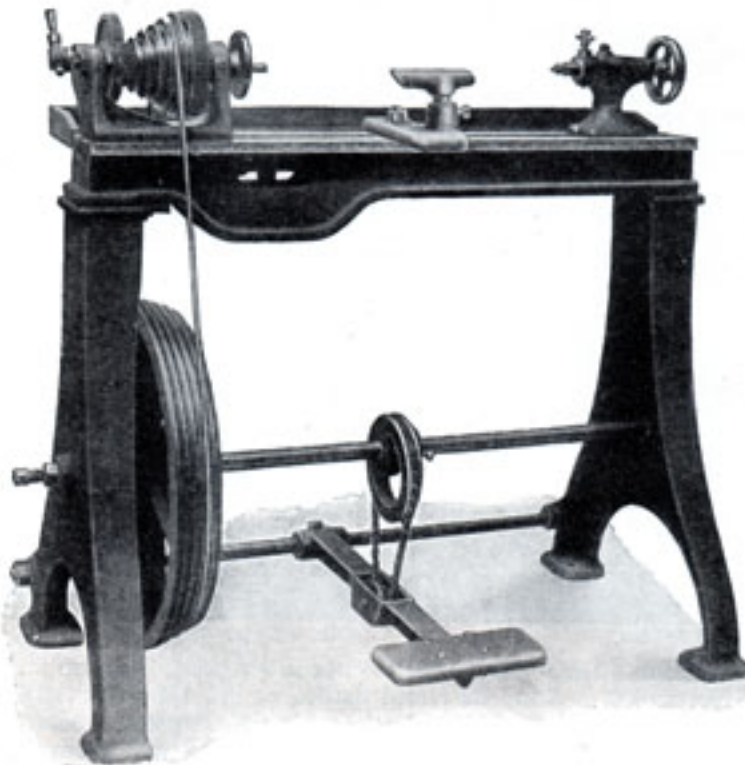

DIMENSIONS.	5 in.	6 in.
Size of Spindle Nose ...	$\frac{7}{8}$ in. Whit.	$1\frac{1}{4}$ in. Whit.
Width of Flat Belt ...	1 in.	$1\frac{1}{2}$ in.
Diameter of Round Belt ...	$\frac{5}{8}$ "	$\frac{7}{8}$ "
Size of Head Cone ...	6 to 3 in.	8 to 4 in.
Length of Bed ...	4 ft.	5 ft.
Depth of Bed ...	$3\frac{1}{2}$ in.	$4\frac{1}{2}$ in.
Admits between Centres	31 "	36 "
Diam. Loose Head Spindle	$\frac{1}{2}$ "	$1\frac{1}{4}$ "
Morse Taper Centres ...	No. 1	No. 2
Size of Treadle Cone ...	22 in.	22 in.
" " Shaft ...	$1\frac{1}{4}$ "	$1\frac{1}{2}$ "
Floor Space required ...	54×30 in.	66×30 in.
Weight as illustrated ...	4 cwt.	$6\frac{1}{2}$ cwt.
Size of Gap ...	$2\frac{1}{2} \times 5$ in.	$4\frac{1}{2} \times 6$ in.
" Counter Pulleys ...	6 in. dia. for 1 in. Belt	8 in. dia. for $1\frac{1}{2}$ in. Belt
" Tools ...	$\frac{1}{2} \times \frac{1}{2}$ in.	$\frac{3}{4} \times \frac{1}{2}$ in.

THE SINGLE SPEED COUNTERSHAFT is provided with cone, and fast and loose pulleys for flat belt. All slides are hand scraped and well fitted. The workmanship and materials used are of the best quality. Face plates for this Lathe can be supplied.

	5 in. Centres.	6 in. Centres.
Price for Treadle Lathe, 4 ft. Gap Bed, single speed with 2 centres, 1 fork centre, 2 Tees. Driving Plate arranged for round belt ...	£18 : 9 : 6	£27 : 7 : 6
Price with Double-geared Headstock, as shown ...	£21 : 10 : 0	£31 : 18 : 6
Extra for Compound Slide Rest ...	£4 : 13 : 6	£5 : 10 : 0
If Straight Bed preferred, deduct ...	£1 : 0 : 0	£1 : 5 : 0
Price for Power with Countershaft deduct ...	£2 : 0 : 0	£2 : 10 : 0
" " and Treadle Lathe, add... ..	£4 : 0 : 0	£4 : 15 : 0

Either of the sizes can be supplied for flat belt at extra cost : 15/- for the 5 in. ; 25/- for the 6 in.

If packed and delivered F.O.B. British Port, 10 per cent. extra.

Carriage Forward.

Bronze Medal 1884—Gold Medal 1890

TOOL AND MACHINE MERCHANTS

WOOD TURNING LATHE

The Lathe, with its component parts, forms a most complete but cheap equipment for the builder, wheelwright, joiner, or pattern maker.

The bed is very massive, truly planed and scraped on face, sides, and edges, and is made in almost any length, with or without the gap.

The headstocks are fitted with either cone or equal pulleys; the spindle is of steel and runs in gun-metal bearings of ample proportions.

The rests are of a simple type, firm and efficient; the poppet is fitted with a square threaded screw and clamping arrangement.

The Lathes, as listed, are sent out complete, ready for use, fitted with fast and loose headstocks, countershaft with pulleys, hangers, etc., and belt striking gear, adjustable tee rest, fork, screw and dead centres.

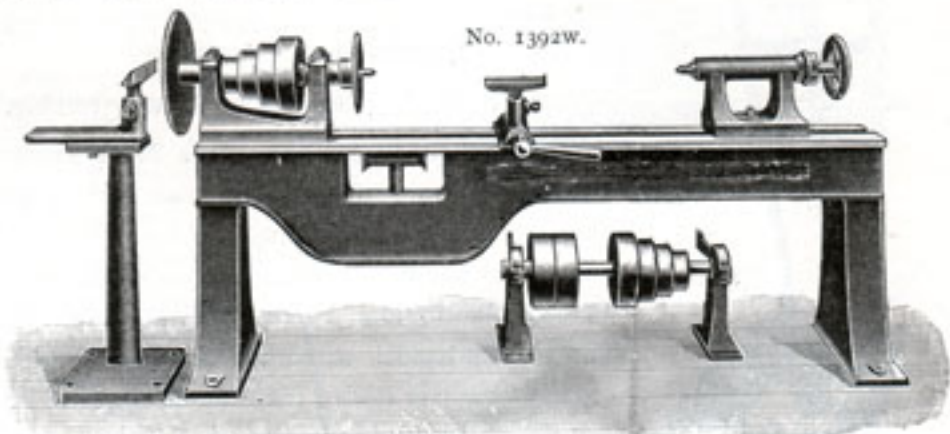

SIZES AND PRICES.

No.	Height of Centres.	Length of Bed.	Length will turn.	Diameter of Pulleys on Countershaft.	Revs. per minute of Countershaft.	Price.
1	6 in.	6 ft.	3 ft. 8 in.	6 in.	800	£31 : 10 : 0
2	8 "	8 "	4 " 11 "	8 "	600	£42 : 10 : 0
3	9 "	10 "	6 " 7 "	10 "	500	£58 : 10 : 0
4	10 "	10 "	6 " 7 "	10 "	400	£68 : 0 : 0
5	12 "	12 "	8 " 3 "	12 "	350	£85 : 0 : 0
Extra Length of Bed, per ft.						£2 : 2 : 6 extra.
.. if fitted with Large Face Plate, Pillar Stand, and Tee Rest, for turning large diameters						£7 : 10 : 0 ..
We also make a special 6 in. centre wood turning lathe with plain bed (no gap), Headstock, Tee Rest, Special Poppet, and Countershaft complete, three steps to Cone Pulleys						£18 : 0 : 0 ..
If with Gap						£23 : 0 : 0 ..
.. Treadle instead of Countershaft, for foot power						Same Price.

WOODWORKER'S TREADLE LATHE

No. 1393W.

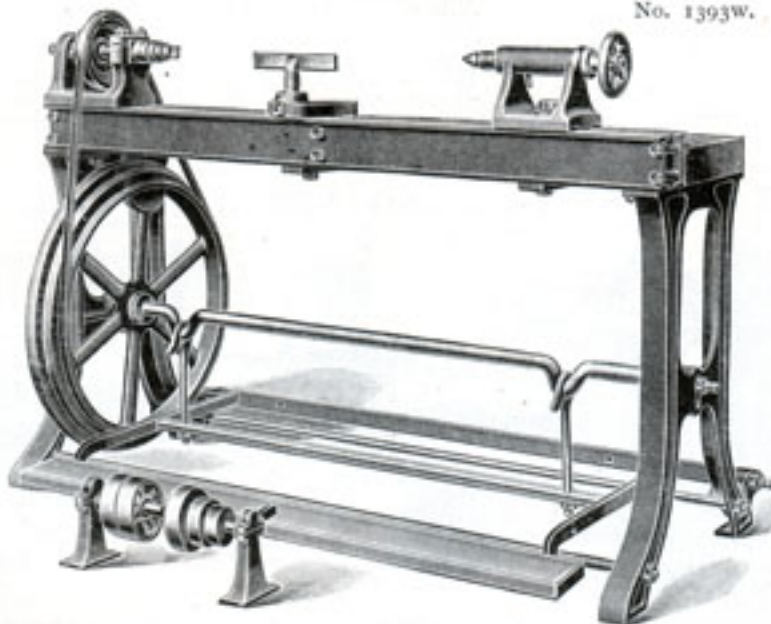

Length of Bed.	Height of Centre.	Length will turn.	Price for Treadle.	Price for Power and Treadle.	Power only with overhead motion.	Extra Price Saw Bench Attachment, 8 in. Saw.
5 ft. Extra per ft. 10/-	Either 5 in. or 6 in.	3 ft.	£15 : 15 : 0	£18 : 18 : 0	£13 : 13 : 0	£3 : 10 : 0

Engineers' Tools and Machinery

PATENT JACK TRUCKS

FOR LIFTING AND CONVEYING LOADS ON
STANDARD PLATFORMS.

Built on sliding wheel system for easy turning.

Operator simply runs the Jack Truck under the loaded platform, lifts platform with load by means of the T handle, and wheels it to its destination, where he has not to wait till it is discharged, but lowers the platform by the same downward movement of T handle, withdraws the Jack Truck, and goes for another load. They can be propelled by the upright handles or pulled by the T handle.

Each Jack is fitted with safety cam and pawl for locking loads when lifted. They are specially adapted for running in and out of lifts.



No. 1394W.

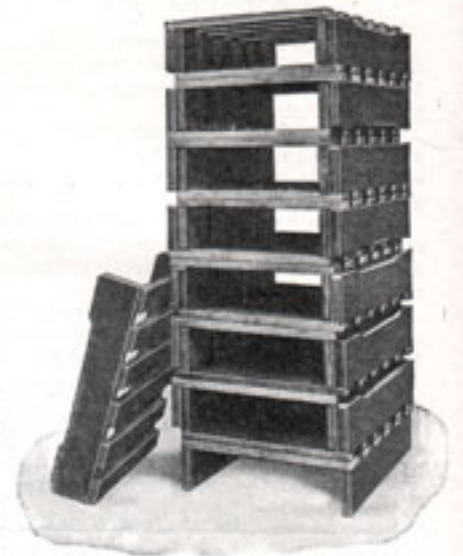

No. 1395W.

Price of JACKS.

Length Overall.	Length from Stoppers.	Width Overall.	Height Lowered.	Lift.	Price.
In.	In.	In.	In.	In.	
29	24	17	5½	1½	190/-
29	24	15	7½	1½	190/-
39	32	15	7½	1½	325/-
39	32	17	5½	1½	325/-
39	32	22	9½	1½	325/-
39	32	22	11½	1½	325/-
45	38	22	9½	2	360/-
45	38	22	11½	2	360/-
45	38	15	10½	2	360/-
45	38	18	7½	2	360/-

Price of PLATFORMS.

Diam. of Wheels.	Size of Standard Wooden Platforms.		Weight.	To carry cwt.	Price.
	Length.	Width.			
In.	In.	In.	Lb.		
5	24	× 27	100	3	21/-
7	24	× 25	100	3	21/-
7	32	× 25	154	6	22/-
5	32	× 27	154	6	22/-
9	32	× 32	154	6	22/-
11	32	× 32	154	6	22/-
9	38	× 32	224	10	28/-
11	38	× 32	252	10	28/-
10	38	× 25	224	10	28/-
7	38	× 28	224	10	28/-

Carriage Forward.

BACK-GEARED SELF-ACTING SCREW-CUTTING LATHE

(No. 2 Pattern.)

No. 1396W.

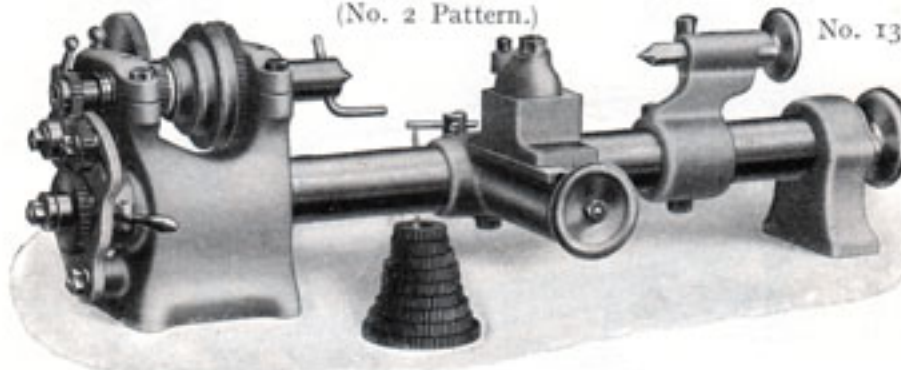

With 13 Change Wheels, which cut all Threads, Right or Left Hand, from 6 T.P.I. to 60 T.P.I., including Metric Pitches.

Takes work up to 4 in. in diameter and 12 in. in length.

Price £6 : 10 : 0 complete as shown.

Driving Wheel, 35/- extra.

Carriage Forward.

Write for a detailed list of this Lathe and Accessories, free on application. For a complete List of Lathes, Drilling Machines, Engineers' Tools, etc., see our Metal Workers' Catalogue.

Builders' and Furnishing Ironmongery

TOOL AND MACHINE MERCHANTS

TRUCKS AND REVOLVING PLATFORM TROLLEYS



No. 1397W.
With four Wheels.

Size.		Height.	Size of Wheels.		Price.	Thick Half-round Rubber Tyres, vulcanised on.
In.	In.	In.	In.	In.	£ s. d.	Each Wheel.
24	16	8	6	12	1:17:6	6/3
30	20	9	6	12	2:5:0	6/3
36	24	9	6	12	2:10:0	6/3
42	24	9	6	12	2:15:0	6/3
48	26	10	8	12	3:10:0	11/-
54	30	12	10	2	5:0:0	17/6
60	36	14	12	2	5:15:0	22/6
72	36	14	12	2	7:0:0	22/6

WAREHOUSE TROLLEY

No. 1398W.

Four-wheel Trolley with iron handles and front wheels to turn underneath.

No.	Size	Price.
No. 1.	2 ft. x 1 ft. 6 in.	£4:15:0
.. 2.	3 .. x 2 ..	5:10:0
.. 3.	4 .. x 2 .. 6 in.	6:15:0
.. 4.	5 .. x 3 ..	8:10:0
.. 5.	6 .. x 4 ..	10:0:0

India-rubber Tyres extra.

Capable of carrying from 5 to 20 cwt. Larger and stronger Trolleys made to order.

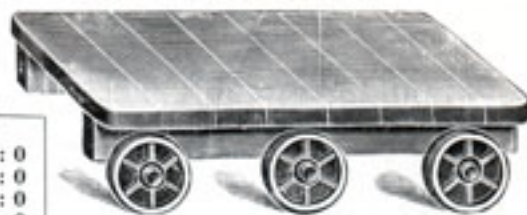

No. 1399W.
With six Wheels.

Size.		Height.	Size of Wheels.		Price.	Thick Half-round Rubber Tyres, vulcanised on.
In.	In.	In.	In.	In.	£ s. d.	Each Wheel.
24	16	8	6	12	2:2:0	6/3
30	20	9	6	12	2:10:0	6/3
36	24	9	6	12	2:15:0	6/3
42	24	9	6	12	3:15:0	6/3
48	26	10	8	12	4:2:6	11/-
54	30	12	10	2	5:15:0	17/6
60	36	14	12	2	6:5:0	22/6
72	36	14	12	2	7:10:0	22/6



WAREHOUSE TRUCKS

No. 1400W.

No. 1.

4 ft. 6 in. high, 8 in. shoe, 10 in. wheels.
Price £3:5:0

Extra for Rubber Tyres, 35/-

No. 2.

4 ft. 10 in. high, 10 in. shoe, 12 in. wheels.
Price £3:10:0

Extra for Rubber Tyres, 45/-

Exceedingly Strong Trucks.

UNIVERSAL TRUCK

No. 1401W.

This Truck is made of well-seasoned hard wood, the sides are slightly curved, the cross bars are straight, wrought iron shoe with round or square front (round sent unless square is ordered). The wood is stained and varnished. The wheels are strong webbed and have long bearings for axles.

No.	Height.	Cross Bars.	Wheels.	Shoe.	Price.
0	3 ft. 2 in.	2	6 in.	3 in.	25/6
1	3 .. 6 ..	2	7 ..	4 ..	28/-
2	3 .. 8 ..	3	8 ..	5 ..	31/-
3	4 .. 0 ..	3	9 ..	6 ..	36/-
4	4 .. 2 ..	4	10 ..	6 ..	43/-

INDIA-RUBBER TYRES (Vulcanised on): No. 0, 12/6; No. 1, 18/-; No. 2, 22/-; No. 3, 30/-; No. 4, 35/- extra.



TROLLEYS FOR REMOVING HEAVY LOADS

No. 1402W.

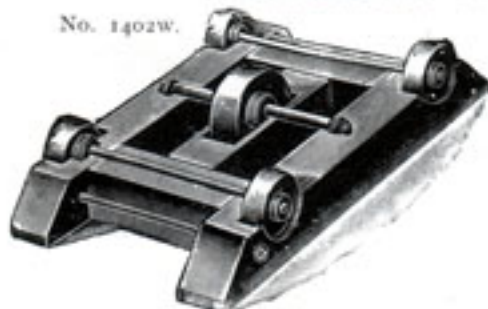

This represents a very useful pattern of English manufacture and is thoroughly recommended.

No. ...	1	2	3
Size ...	18 x 12	22 x 16	30 x 24 in.
Price ...	30/-	32/6	55/- ea.

The "SAMSON" is a most useful appliance for wharf and warehouse use, or wherever the easy moving of heavy packages is desired. The timber used in the manufacture of these Trucks is the best selected hardwood, and the wheels and axles are made specially strong.

Sizes and Prices:

No. 1, 36 x 24 in., six wheels, to carry 50 cwt.

£3:10:0

No. 2, 22 x 16 in., five wheels, to carry 30 cwt.

£1:18:0

All Carriage Forward.

No. 1403W.

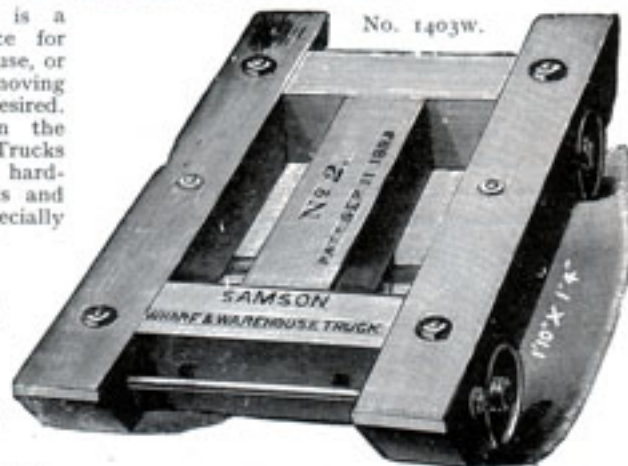

Horticultural and Estate Appliances

RICHARD MELHUISE LIMITED, LONDON, E.C.

SETS OF TOOLS IN FOLDING LEATHER CASES (Fitting One Handle)
 FOR MOTORISTS AND OTHERS. WARRANTED FIRST QUALITY



No. 1404w.

Containing Saw, Handle, Tin Opener, Hammer, Piercer, Sheath for Saw, Corkscrew, File, Screwdriver, Chisel, Gimlet, and Knife. Price 15/- complete.



No. 1405w. Containing Handle, Corkscrew, File, Hammer, Saw, Chisel, Gimlets, Screwdriver, Piercer, and Knife. Price 10/6 complete.

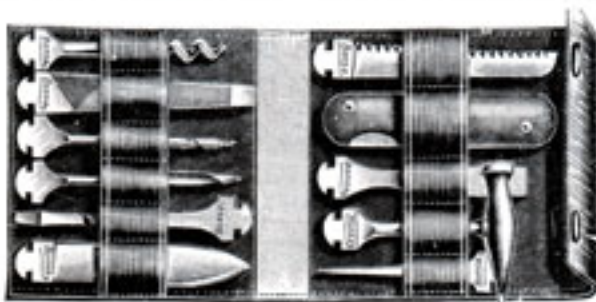

No. 1406w.

Containing Saw, Handle, Chisel, Hammer, Piercer, Corkscrew, File with Screwdriver end, Gimlets, Screwdriver, and Knife. Price 15/6 complete.

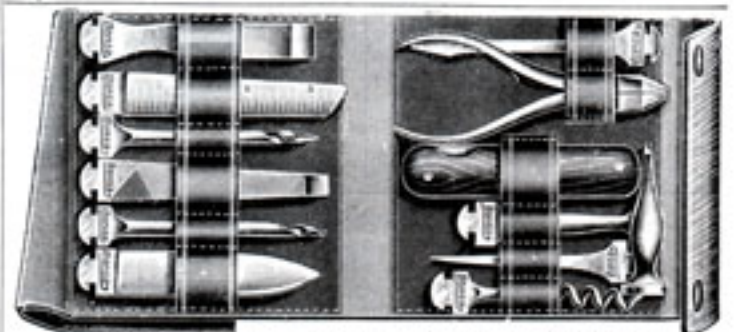

No. 1407w. Containing Screwdriver, Pliers, Handle, Hammer, Piercer, Corkscrew, Chisel, Saw with Sheath, Gimlets, File, and Knife. Price 17/6 complete.

No. 1408w. Containing Files, Pincers, Corkscrew, Handle, Hammer, Screwdriver, Saw with Sheath, Piercer, Pliers, Gimlets, Chisel, Tin

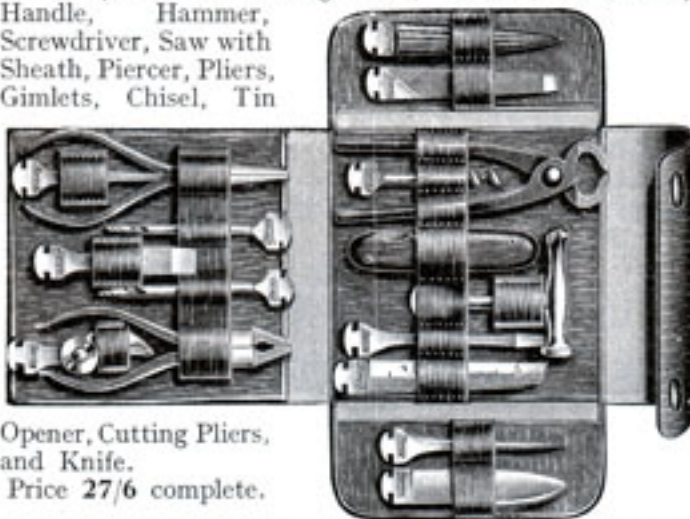

Opener, Cutting Pliers, and Knife. Price 27/6 complete.

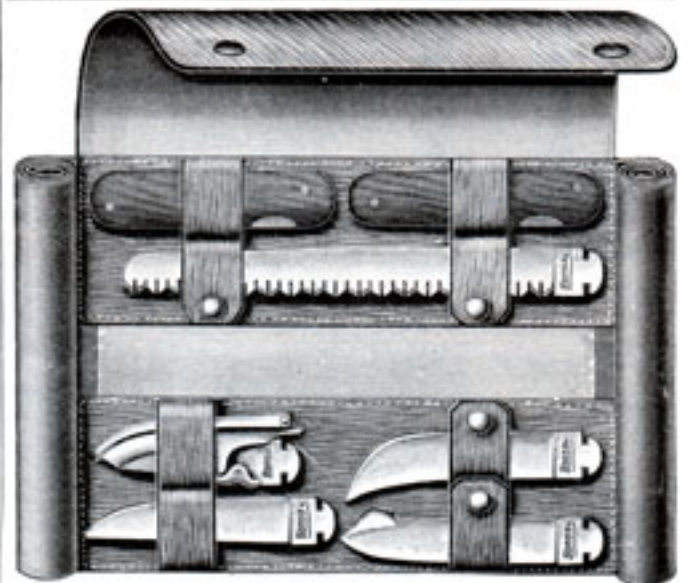

THE GARDENER'S SET

No. 1409w. Consisting of 2 Cocoa-wood Handles, 3 Pruning Knife Blades, Pruning Shears, and 7 in. Saw. Price 17/6 complete.

No. 1410w. Containing Adjustable Spanner, Handle, Hammer, Corkscrew, Pricker, Nail Punch, Saw with Sheath, File with Screwdriver end, Gimlets, Chisel, Screwdriver, and Knife. Price 21/- complete.

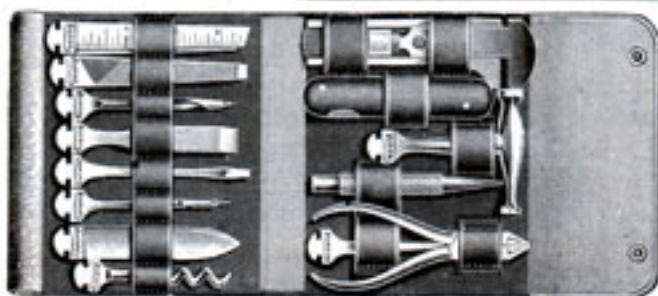

Electric and Wireless Engineers

TOOL AND MACHINE MERCHANTS

SETS OF TOOLS IN FOLDING LEATHER CASES

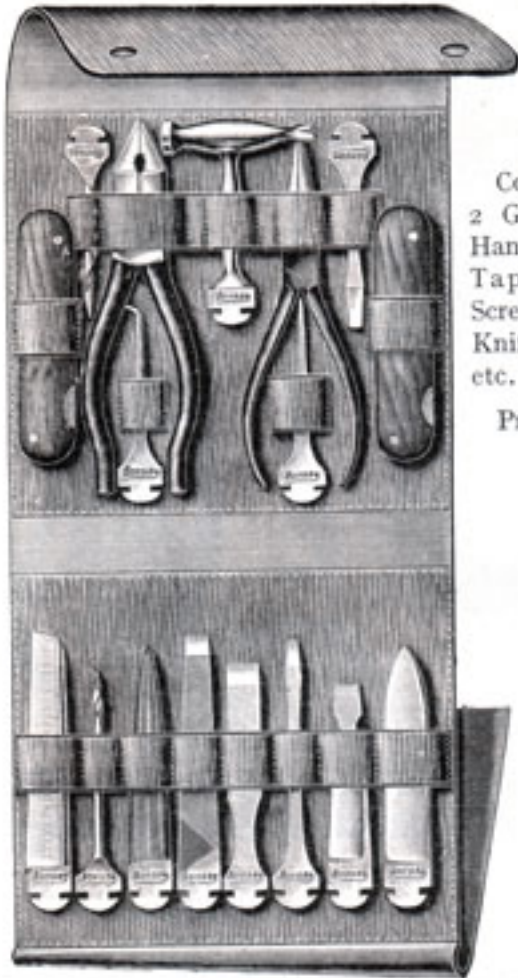

SUITABLE FOR
ELECTRICIANS,
MOTORISTS, ETC.

No. 1411W.

Containing 2 Handles,
2 Gimlets, Insulated
Handled Pliers, Hammer,
Taper-nose Pliers, 2
Screwdrivers, Saw, Files,
Knife, Prickers, Chisel,
etc.

Price 27/6 complete.

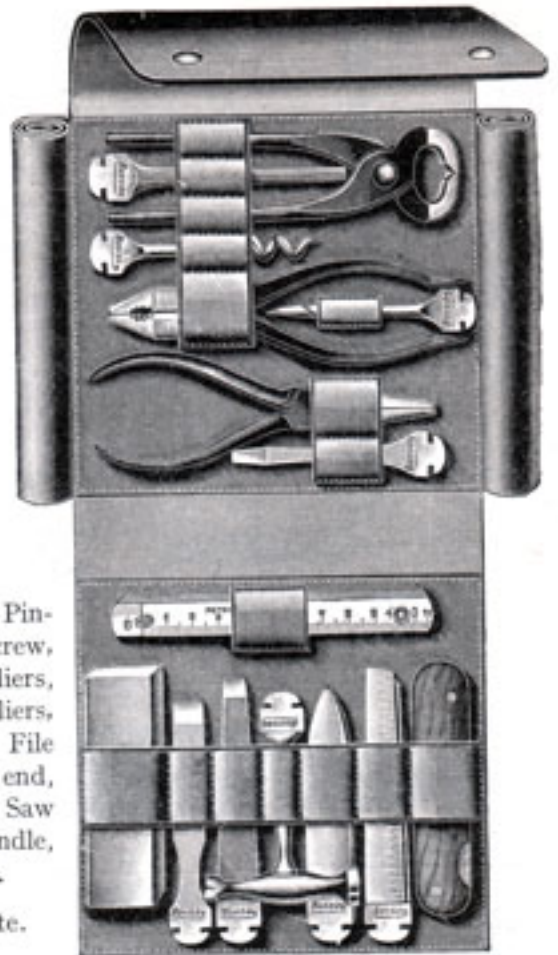

No. 1412W.

Containing pair Pin-
ners, File, Corkscrew,
Flat-nose Cutting Pliers,
Gimlet, Taper-nose Pliers,
Screwdriver, Chisel, File
with Screwdriver end,
Hammer, Knife, Saw
with Sheath, Handle,
Rule, and Nail Box.

Price 30/- complete.

MELHUISSH'S PATENT TOOL ROLLS No. 1413W.

These are made of the very best Tanned Leather and Canvas. Each Roll is fitted with 24 steel clips for holding carpenters' and other tools (the most convenient and easy way of doing this). They will stand a lot of hard wear, and are practically dust-proof—3 canvas flaps cover all the tools before rolling them up. Size of roll 24 x 12 in.

Price 17/6 empty.

No. 1414W.

Complete with
Motor or Engi-
neers' Tools.
10 in. Billings
Pattern Wrench.
6 in. Wrench.
Pair 7 in. Com-
bination Pliers.
8 in. Cold Chisel.
12 oz. Ball Pane
Hammer.
2 Screwdrivers, 3
and 6 in.
Pin Hammer.
1 each Round,
Flat, and Half-
round Files.
Centre Punch.
Pin Punch.
Hand Vice.
Pair Burner Pliers.
Price 35/- complete.

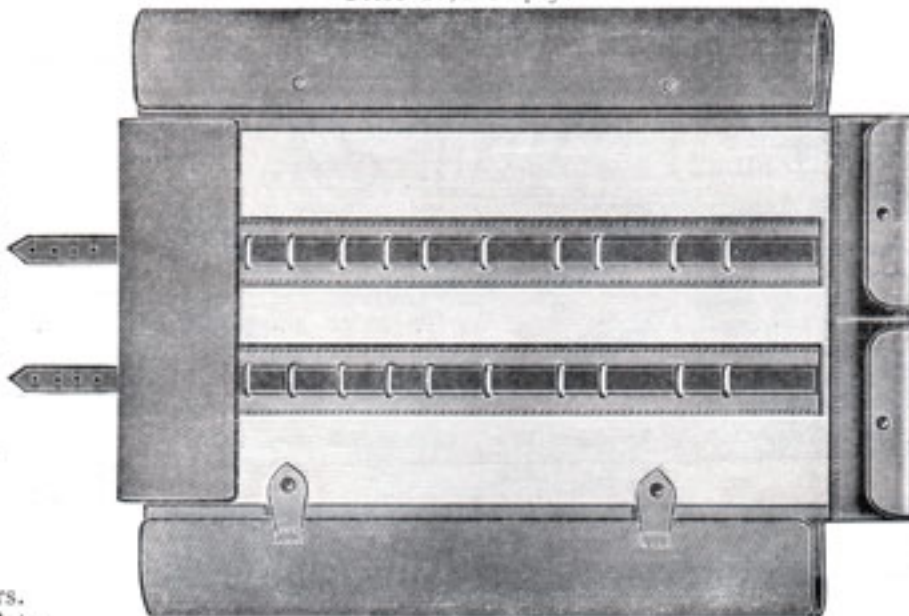

No. 1415W.

Complete with
Carpenters' Tools
as specified.
Hammer.
4 and 6 in.
Screwdrivers.
Pair 7 in. Pincers.
Oilstone.
½ and 1 in.
Chisel.
6 in. Wood Rasp.
Keyhole Saw
complete.
2 Bradawls.
2 ft. Rule.
Gimlet.
Price 32/-
complete.

Bronze Medal 1884—Gold Medal 1890

FRETWORK TOOLS

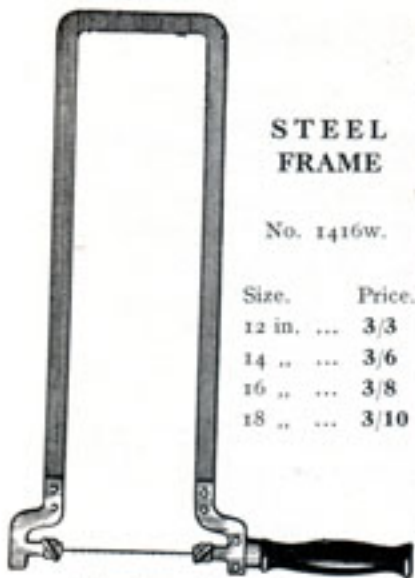

STEEL FRAME

No. 1416W.

Size.	Price.
12 in. ...	3/3
14	3/6
16	3/8
18	3/10

Very strong. With Patent Clamps. Thumbscrews can be tightened with thumb and finger. Less expensive frames from 2/- upwards.

THE A1 BOX OF TOOLS, DESIGNS, AND MATERIALS

No. 1417W.

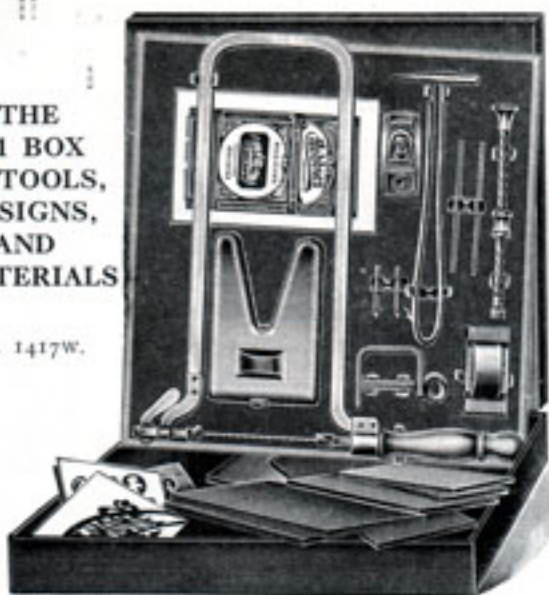

Price 16/6. More advanced Sets, up to 30/-.
Cheaper Sets on Cards, 4/6 to 14/3 per set.

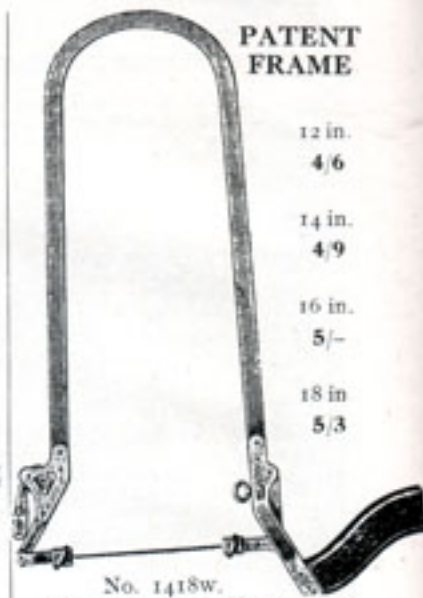

PATENT FRAME

12 in.	4/6
14 in.	4/9
16 in.	5/-
18 in.	5/3

No. 1418W.
With improved Handle and Lever Frame. The best on the market.



No. 1419W.

Sizes 00 to 6. Price -/5 per doz.; 4/6 per gross.

HOBBIES FRET BLADES No. 1420W.
Sizes 00 to 6. -/9 per doz.



SAWS FOR CUTTING METAL No. 1421W.

The same length as Saws for Wood.

Sizes 00 to 6. Price -/6 per doz.; 5/6 per gross.



FRET-CUTTING TABLE

No. 1422W.

In Metal. Nicely Nickelled.
Price 1/6 each.

PATENT METAL FRET-CUTTING TABLES

These Tables, made to supersede the wooden ones, are of softer metal than the Saws, and consequently do not injure them; although when the Saw touches the Table the worker is immediately aware of the fact.

SET OF TWELVE ASSORTED FRET DRILLS

No. 1423W.



Price, in Tubes -/8 per set.

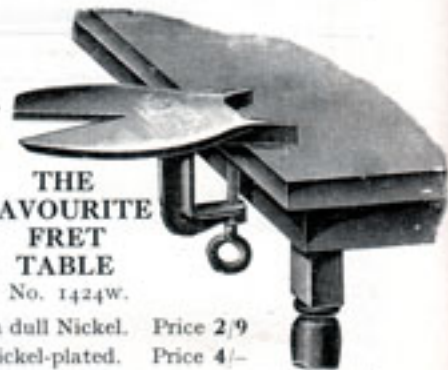

THE FAVOURITE FRET TABLE

No. 1424W.

In dull Nickel. Price 2/9
Nickel-plated. Price 4/-

CARD OF SIX ASSORTED FILES FOR FRETWORK No. 1425W.



Price 1/3 per card.

FRETWOOD No. 1426W.

	1/2	3/4	1 in.
Satin Walnut	-6	-8	-10 ft.
Oak ...	-11	1/-	1/3 ..
Whitewood ...	-7	-8	-10 ..
Walnut ...	-9	-11	1/- ..
Mahogany ...	-8	-10	-11 ..

Width of boards, 7-12 in.



NO 6435 CARPENTERS EAGLE PENCIL C9 LONDON

CARPENTERS' OVAL PENCILS No. 1427W.

Price -/1 1/2 each; 1/1 per doz.;
12/- per gross.

AMATEUR LATHE AND FRETSAW



No. 1428w.

This Lathe is patterned almost exactly after the latest improved lathes now used in the best machine shops. The large driving wheel has two grooves, of varying depths, on its face. The lathe head is provided with a 2 in. face plate, a spur centre, a screw centre for turning cups, and also with a very nice drill chuck to hold $\frac{1}{2}$ in. round twist drills for drilling wood or iron. It has also on the outer side of the pulley a solid emery wheel and drill spindle, with set screw to hold drill points. The tailstock has a screw-feed centre, which is secured at any point desired by a clamping arrangement. It is also provided with a long and short Tool Rest, 5 Turning Tools, Wrench, Drill Points, etc. etc. Swing of lathe, 5 in.; length of bed, 24 in.; distance between centres, 13 $\frac{1}{2}$ in.

The Scroll Sawing Attachment (as seen in the cut) is secured to the lathe bed by one bolt, and can be put on or off at pleasure. This attachment has all the improvements.

The Circular Saw Attachment consists of a Saw Table 7 x 6 in., a Saw 3 in. diameter, and a Saw Arbor. The Lathe Rest Socket is used to support the table.

Weight, 78 lb.

Price of Lathe and Tools with Scroll Saw	£5 : 16 : 6
Attachment, complete in Case	£1 : 0 : 6
Price of Scroll Saw Attachment only	6 : 6

No. 1430w.

This Machine is larger and heavier than the old "Rogers," but is of the same general construction. There are two balance wheels, one each of iron and emery, the extra weight of additional wheel giving steadiness to the motion.

The emery wheel is fastened by adjustable clamps, which can also be used for holding various other sizes of emery wheels, buffing wheels, etc.

To adjust the arms, all that is necessary is to loosen the bolt which goes through the upper arm in front of casting, and crowd the arm sideways either to right or left and into line with the lower one; the hole in casting is elongated to permit of change in position as described. The table is japanned and the general finish of the Saw same as other machines. It weighs, net, 37 lb., and boxed, 55 lb.

Price, in Box	69/- each.
----------------------	------------



No. 1429w.

This Machine has been quite a favourite for some considerable time. The table is round, with rolled edges, an improvement on the old pattern. It is fitted with patent tilting arrangement, by which a maximum angle may be secured without using a slot more than $\frac{1}{4}$ in. wide. The wooden arm is kept from warping by means of a steel truss, and the distance between the saw and back frame is 18 in. Patent clamps securely grip the finest fretsaws, and they are so made that the lever cannot fly back and

loosen the tension of the saw. The end of the balance wheel spindle will hold a drill. Price, with Screwdriver, Spanner, 1 doz. Saws, and 2 Designs, 50/- each.

Side Wings for supporting large work can be supplied at an extra cost of 4/6.

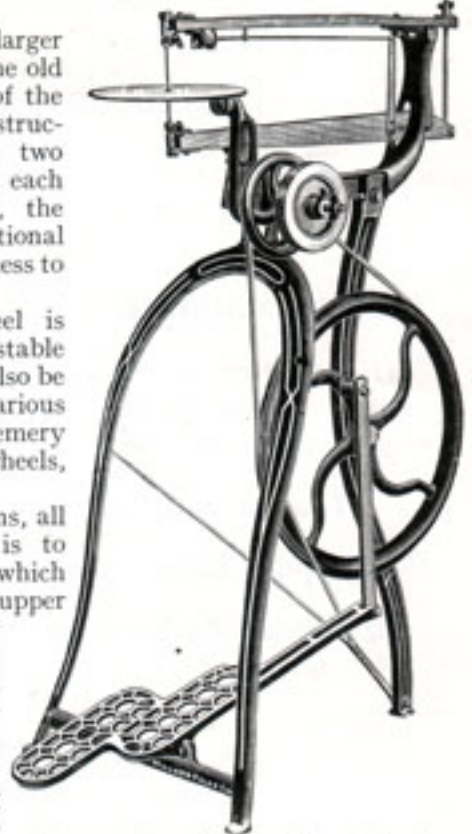

RICHARD MELHUISH LIMITED, LONDON, E.C.

WOOD BORING MACHINE No. 1431W.

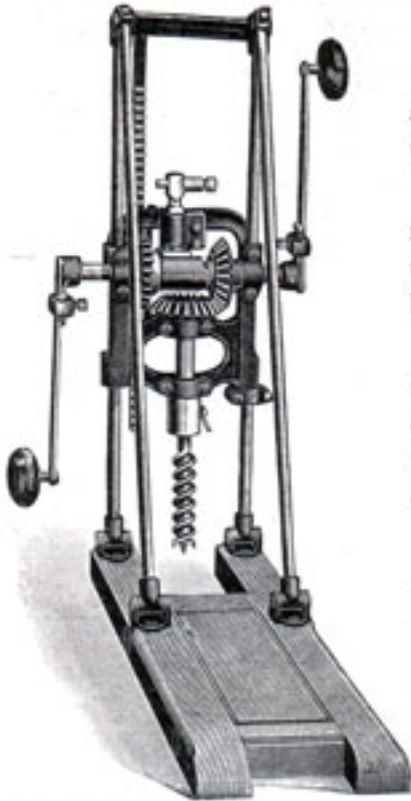

The frame is made of $\frac{1}{2}$ in. round steel rods; the braces are the same, and attached to the rods at the top by a set screw. When this set screw is loosened, the frame falls over so as to bore at any desired angle.

The depth of hole to be bored is fixed by a stop, as seen on the left-hand upright rod in the cut. When the frame strikes this top, lift the latch, and the machine throws itself into gear by the use of a spring, and the auger is lifted out of the hole by continuing to turn the crank in the same direction.

When the auger is drawn from the hole, the frame hangs itself up until the machine is moved to the next hole; then it is dropped down by turning the crank back until the auger strikes the wood, when it is thrown out of gear, and proceeds to bore the next hole. As seen in the cut, the machine has adjustable cranks, which fully regulate its speed and power. It bores to a depth of 12 in.

Price **£3 : 10 : 0.** Augers extra.

BORING MACHINE AUGER No. 1432W. With $\frac{1}{2}$ in. Shank.

Size	...	$\frac{1}{8}$	$\frac{9}{16}$	$\frac{3}{4}$	$\frac{7}{8}$	1	1 $\frac{1}{8}$	1 $\frac{1}{4}$	1 $\frac{3}{8}$	1 $\frac{1}{2}$	1 $\frac{3}{4}$	2	in.
Price	...	4/-	4/6	4/9	5/-	5/3	5/6	6/6	7/6	8/6	9/-	10/6	12/6 each.

BORING MACHINE No. 1433W.

This is a very good pattern and made of best seasoned timber. It is a most economical and useful Machine.

Price, as shown, **£2 : 5 : 0.**

If fixed (upright Machine), price **£1 : 18 : 6**

Augers extra. See above, No. 1432W.

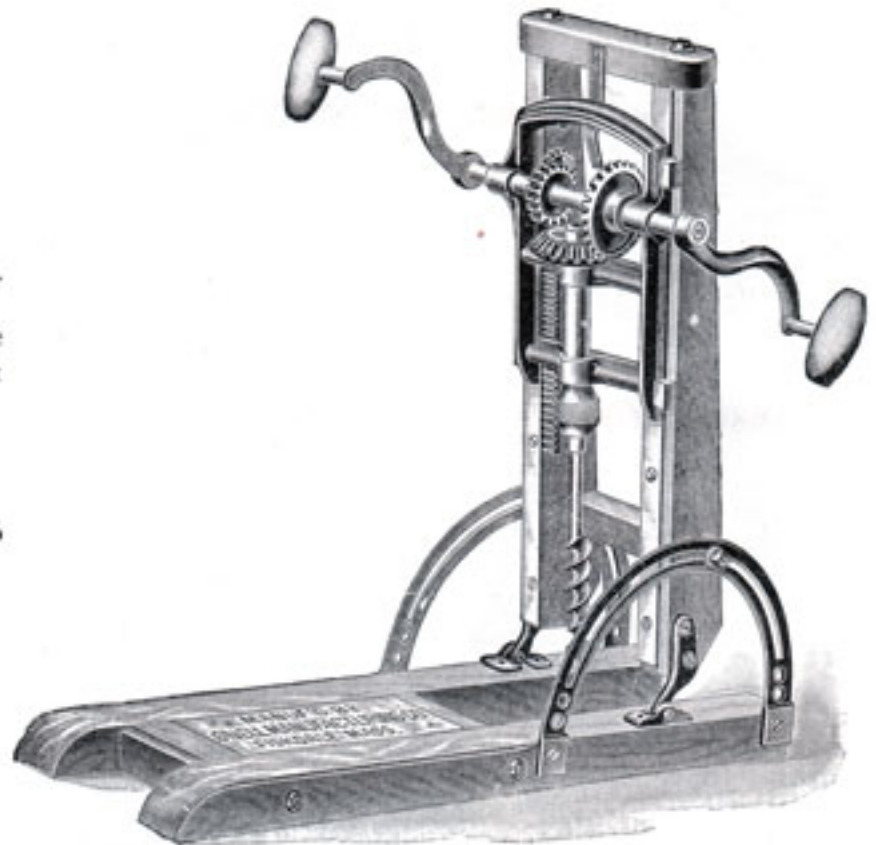

TOOL AND MACHINE MERCHANTS

SCREENS No. 1434W.

For Gravel, Sand, Lime, Cinders, Coal, Malt, Corn, etc. etc.

Strongly made of 1½ in. Yellow Deal, with Iron Clamps and Strong Iron Bars at back.



Laced Pattern. Extra Strong.

Mesh	1/8	3/16	1/4	5/16	3/8	1/2	in.
5 ft. 6 in. × 2 ft. 9 in.			33/9	34/9	35/9	37/6	39/6	47/-	each.

Locketed Screens. Extra Strong.

Mesh	1/8	3/16	1/4	5/16	3/8	1/2	in.
6 × 3 ft.			42/9	44/9	46/6	48/6	50/3	61/6	each.

Carriage Forward.

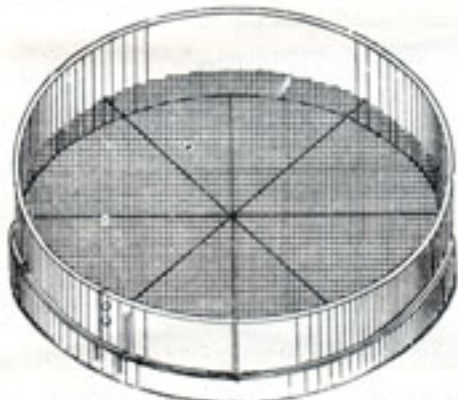

20 IN. BUILDERS' AND 'PLASTERERS' SIEVES No. 1435W.

Iron Wire Bottoms, Strong Rims, 3½ in. deep inside, 4 to 12 mesh, 4/6 each; 14 to 16 mesh, 5/- each.



20 IN. EXTRA STRONG STRAIGHT MESH GRAVEL SIEVES

No. 1436W.

Mesh	1/8	3/16	1/4	5/16	3/8	1/2	in.
Price ...			4/9	5/-	5/3	5/6	each.		

SWEEPS OF LONG THIN PARING GOUGES

No. 409w, page 34

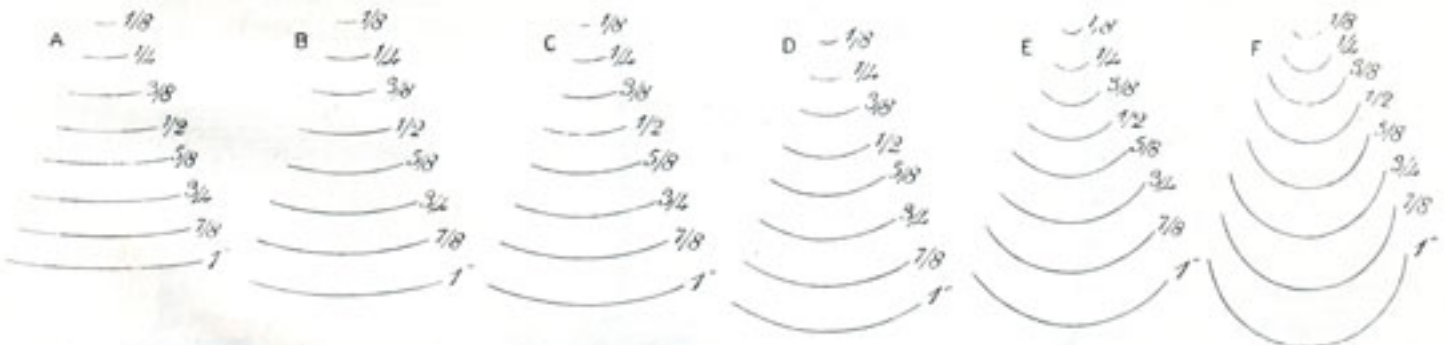

NOTE: These sweeps refer to Long Thin Paring Gouges No. 409w only.

NOTE.—This section of our Catalogue contains the leading lines in Woodworkers' Tools, Machines, and Accessories. Other sections embracing a great variety of Engineers' Tools, Machines, and Appliances, Electrical and Wireless Goods, Motor Tools, Horticultural and Estate Agents' Requirements, Builders' and Furnishing Ironmongery, Sanitary Fittings, etc., will be sent per post on application.

Call and inspect our new Showrooms at 84, Fetter Lane, E.C. A large variety of Bathroom fittings in Porcelain, Enamelled and Nickel-plated. Estimates for Complete Equipments free.

Electric and Wireless Engineers

RICHARD MELHUIH LIMITED, LONDON, E.C.

CONTRACTORS' TOOLS



TIMBER JACK

No. 1440w.

Single Purchase.

High, when down.	Rise.	To lift	Price.
32 in.	18½ in.	2 tons	£5 : 5 : 0
36 ..	21 ..	3 ..	£5 : 17 : 6

Double Purchase.

30 ..	12½ in.	6 tons	£11 : 10 : 0
-------	---------	--------	--------------



TIMBER DOGS

No. 1441w.

To lift	Take in.	Price.
Tons.	In.	
1½	15	£3 : 19 : 6
2	21	£4 : 7 : 6
3	27	£5 : 10 : 0

ASH LEVERS

No. 1442w.



Length	6	7	ft.
Price	25/-	32/-	ea.
Length	...	8	ft.
Price	...	37/6	ea.

WHEELBARROWS

For Home or Export.

No. 1443w.

No. 1. Size of body, 31 × 26 in.; front depth, 12 in.; back ditto, 6 in.

No. 2. Size of body, 34 × 29 in.; front depth, 14 in.; back ditto, 7 in.

Capacity, 3 ft. (cubic) and 3½ ft. respectively. Legs of flat steel, body painted.

Price, No. 1, 35/-; No. 2, 37/6 each.



CONTRACTORS' PICKS

No. 1444w.



Weight...	4	5	6	7	lb.
Price ...	2/3	2/6	2/9	3/-	each.

Handles for same, 36 in. long. Best, 1/10; Second, 1/6 each. See page 68.

LONDON SHOVELS

No. 1445w.

Riveted Eye Handles.

Prices :

No. 1.
12 × 9½ in., 4/- each.

No. 2.
12½ × 10 in., 4/3 each.

With 2 Rivets in Eye.

No. 1446w.

Prices :

No. 1.
12 × 9½ in., 4/3 each.

No. 2.
12½ × 10 in., 4/6 each.



SOLID STEEL OPEN SOCKET SQUARE SHOVELS

No. 1447w.

Riveted Eyes.

Prices :

No. 1.
12 × 9½ in., 2/5 each.

No. 2.
12½ × 10 in., 2/6 each.

No. 3.
13 × 10½ in., 2/7 each.

No. 4.
13½ × 11 in., 2/8 each.

No. 6.
14½ × 12 in., 3/- each.

No. 7.
15 × 12 in., 3/2 each.

No. 8.
15½ × 12 in., 3/6 each.



STEEL GRAVEL SHOVELS

No. 1448w.

T Handles, Stamped Steel.

Prices :

No. 1.
13 × 11½ in., 2/5 each.

No. 2.
13½ × 12 in., 2/6 each.

Solid Wrought Shovels.

No. 1449w.

Prices :

No. 2.
12½ × 11 in., 4/- each.

No. 3.
13 × 11½ in., 4/3 each.

If with D shape Handles, 3/- per doz. extra.



Bronze Medal 1884—Gold Medal 1890

TOOL AND MACHINE MERCHANTS



SACK WEIGHING MACHINE

FOR FARMERS, MILLERS, ETC.

No. 1450W.

This has a heavy cast iron frame, pillars, and lever, thick, well-seasoned elm boards, steel centres and bearings.

To weigh	3	4	cwt.
Price	120/-	130/-	each.

Extras :

Folding Side Wings	22/6	26/-	..
---------------------------	------	------	----

PRICES OF WEIGHTS :

	14	28	56	lb.
Price	7/-	12/6	19/6	each.

PLATFORM WEIGHING MACHINE

HEAVY TYPE.

No. 1451W.

This has an extra heavy frame and pillar, relieving gear, steel centres and bearings, nickel-plated steelyard, japanned black and gold. Supplied with two wheels up to 5 cwt.; four wheels for larger sizes.

Capacity	2	3	4	5	7	10	12	15	20	cwt.
Size of platform ...	19x19	20x23	20x24	22x26	26x30	31x35	31x36	34x38	36x36	
With Back Rail as shown	160/-	200/-	216/-	236/-	325/-	376/-	428/-	468/-	546/-	
Size of platform ...	18x18	20x22	22x22	22x26	26x26	30x30	31x31	34x34	36x36	in.
Without Back Rail ...	153/-	184/-	197/-	214/-	305/-	353/-	402/-	436/-	513/-	



Guaranteed to meet the requirements of Board of Trade Local Inspector.

(Carriage Forward.)

CHIMNEY SWEEPING AND DRAIN CLEARING MACHINES



No. 1452W.

COMPLETE AS SHOWN.

Comprising best quality 3 ft. red Malacca canes fitted best brass screws and sockets, with 18 in. brass chimney brush, Archimedian screw for drain clearing, with pair of straps.

Length ...	30	40	50	60	70	80	90	100	ft.
Price ...	30/-	37/6	47/6	55/-	62/6	72/6	80/-	87/6	each.

The illustration shows a Machine suitable for builders' and contractors' heavy work, and consists of specially tested red Malacca canes, fitted with interchangeable brass screws riveted on to canes, and includes brass clearing wheel, double worm screw, 4 in. W.C. stout rubber plunger in brass fittings for unstopping W.C.'s, drain brush, and straps.



No. 1453W.

Length ...	30	40	50	60	70	80	100	150	200	ft.
Price ...	35/-	42/-	52/-	59/-	66/9	75/-	90/-	132/-	171/6	complete.

Extra 3 ft. Canes, 2/3 each.

Engineers' Tools and Machinery

PATENT TELESCOPIC EXTENSION LADDERS

BUILT LIKE A FIRE ESCAPE. SECTIONS SLIDE INSIDE ONE ANOTHER.

WORLD'S RECORD AWARD

No. 1454W.

IN TWO SECTIONS.

Equivalent to a Builder's Ladder having	21 Rungs 14 ft., closes to	8 ft.	Hardwood Rungs included.	£ s. d.
"	24	" 16	" 9	2:17:0
"	27	" 18	" 10	3:4:0
"	30	" 20	" 11	3:10:0
"	33	" 22	" 12	3:17:0
"	36	" 24	" 13	4:6:0
"	39	" 26	" 14	4:14:0
"	42	" 28	" 15	5:3:0
"	45	" 30	" 16	5:12:0
"	48	" 32	" 17	6:3:0
"	51	" 34	" 18	6:14:0
"	53	" 35	" 19	7:5:0
"	55	" 37	" 20	7:16:0
"	57	" 39	" 21	8:7:0
"	61	" 41	" 22	8:18:0
"	64	" 43	" 23	9:9:0
"	66	" 44	" 24	10:0:0
"			" 24	10:11:0

RECOMMENDED.—2-Section Ladders, 37 ft. and over, reinforced with Steel Wire Rope in backs of sides for 15 per cent. extra.

IN THREE SECTIONS.

Equivalent to a Builder's Ladder having	30 Rungs 20 ft., closes to	8 ft.	Hardwood Rungs included.	£ s. d.
"	34	" 23	" 9	5:1:0
"	39	" 26	" 10	5:10:0
"	45	" 30	" 11	6:1:0
"	48	" 32	" 12	7:3:0
"	51	" 34	" 13	8:5:0
"	54	" 36	" 14	9:7:0
"	57	" 38	" 15	10:9:0
"	63	" 42	" 16	11:11:0
"	69	" 46	" 17	12:13:0
"	72	" 48	" 18	13:15:0
"	75	" 50	" 19	14:17:0
"	78	" 52	" 20	15:19:0
"	82	" 55	" 21	17:1:0
"	87	" 58	" 22	18:3:0
"	91	" 61	" 23	19:5:0
"	96	" 64	" 24	20:7:0
"	100	" 67	" 25	21:9:0
"	105	" 70	" 26	22:11:0
"			" 26	23:13:0

RECOMMENDED.—3-Section Ladders, 46 ft. and over, reinforced with Steel Wire Rope in backs of sides for 10 per cent. extra.

THE SAFEST, SIMPLEST EXTENSION LADDERS MADE.

UNEQUALLED FOR COMPACTNESS, RIGIDITY, AND STRENGTH.

ABSOLUTELY NOTHING TO GO WRONG.

SECTIONS lock at any height. No fittings to interfere or injure user's hands whilst extending or closing Ladders.

ROPES are simply pulled with ONE motion: the Patent Automatic Locks adjust or release THEMSELVES. Extra Pulley and Rope provided on the longer sizes.

TOP of the Ladder being narrower than the bottom obviates top-heaviness.

MIDDLE or OVERLAP of Ladders is the strongest part.

SECTIONS MAY BE DETACHED INSTANTLY, thus forming Single Ladders.

A WELL-MADE LADDER FOR UNIVERSAL USE.

PATENT AUTOMATIC LOCKS in one piece of solid Malleable Iron. The only One-piece Auto Lock in existence, and guaranteed.

THE WHOLE BRITISH MADE BY MEN OF LONG EXPERIENCE.

A PRACTICAL, SIMPLE, AND SAFE LADDER. FIT FOR SERVICE ANYWHERE.

SPECIFICATION :

SIDES.—First Quality Seasoned Straight Grained Archangel White or Red Deal.

RUNGS.—Prime, Tough, Seasoned Quebec Birch, oblong in section, properly HOUSED and mortised into sides, and pinned and wedged. It is impossible for any Rung to turn round, as is often the case with round rungs.

NOTE.—Owing to the uncertainty of further supplies, we reserve the right to use other suitable kinds of timber, when present stock is exhausted.

ROPE.—Best quality, fitted with Special Hooks for detaching.

PULLEYS.—UNBREAKABLE MALLEABLE Frames with Heavy Sheaves (our Special Design).

CLIPS.—Best Iron HAND-FORGED.

LOCKS.—UNBREAKABLE, specially annealed, Malleable, and BUSHED.



3 Sections.



2 Sections.

Fully Extended.

Carriage Forward.

Builders' and Furnishing Ironmongery

TOOL AND MACHINE MERCHANTS

PATENT AUTOMATIC FOLDING PLATFORM STEPS

Invented after practical experimenting and exhaustive tests. Efficiency is proved by the remarkable demand that these have commanded during the short time they have been on the market. Adopted by all who wish to prevent accidents.

SAFETY.—Absolutely rigid when in use, the spacious platform allows the user to stand as comfortable as on the floor itself, and enables free use of both hands. The extended side and back supports act as guards.

PORTABILITY.—No heavier than ordinary steps, and they fold much more compactly, the back supports closing over the front, and the platform folds and opens automatically. This applies to both Single-back and Twin-back Patterns.

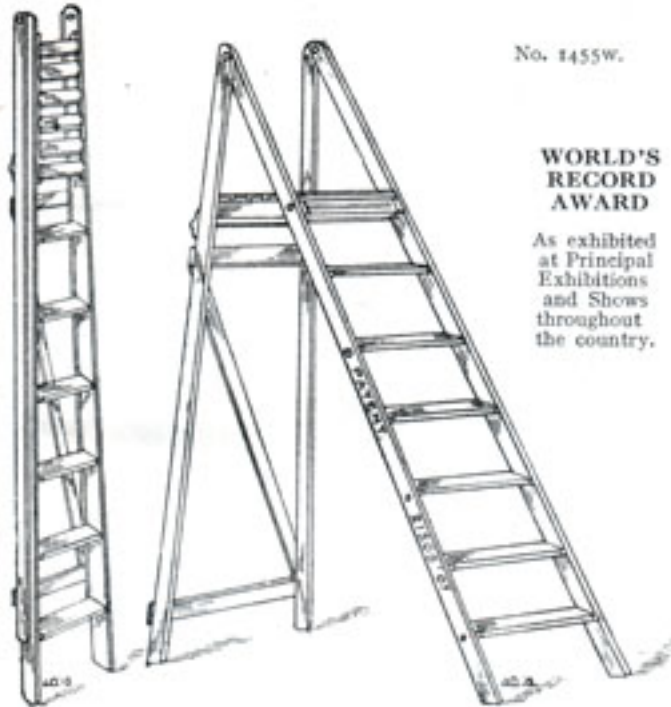

No. 1455W.

WORLD'S RECORD AWARD

As exhibited at Principal Exhibitions and Shows throughout the country.

Stand on the Platform and have both hands to work with, just like standing on the floor.

MANY THOUSANDS IN USE.

INEXPENSIVE PUSH-UP EXTENSION LADDERS

No. 1456W.

Lock at any height and sections are detachable.



Quite suitable where Ladder is required for occasional use.

Man can reach	Height overall.	Height to Platform.	Medium Weight for House or Garden, etc.	Extra strong for Painters' use.
8 ft.	4 ft.	2 ft.	15/-	—
9 "	5 "	3 "	16/-	—
9 " 9 in.	5 " 6 in.	3 " 9 in.	18/-	—
10 " 6 "	6 " 6 "	4 " 6 "	20/-	25/-
11 " 3 "	7 " 6 "	5 " 3 "	25/-	30/-
12 "	8 " 6 "	6 " 3 "	30/-	35/-
13 "	9 " 6 "	7 "	35/-	40/-
14 "	10 " 6 "	8 "	40/-	45/-
15 "	11 " 6 "	9 "	45/-	50/-
16 "	12 " 6 "	10 "	50/-	55/-
17 "	13 " 6 "	11 "	55/-	60/-
18 "	14 " 6 "	12 "	60/-	65/-
19 "	15 " 6 "	13 "	65/-	70/-
20 "	16 " 6 "	14 "	70/-	75/-
21 "	17 " 6 "	15 "	75/-	80/-
22 "	18 " 6 "	16 "	80/-	90/-

TWO SECTIONS

Height closed.	Extends to	Hardwood Rungs.
6 ft.	10 ft.	25/-
7 "	12 "	30/-
8 "	14 "	35/-
9 "	16 "	45/-
10 "	18 "	50/-
11 "	20 "	55/-
12 "	22 "	65/-
14 "	26 "	75/-
16 "	30 "	85/-
18 "	34 "	95/-

THREE SECTIONS

Height closed.	Extends to	Hardwood Rungs.
6 ft.	16 ft.	55/-
7 "	18 "	60/-
8 "	20 "	65/-
9 "	24 "	70/-
10 "	26 "	80/-
11 "	29 "	90/-
12 "	32 "	110/-
14 "	38 "	120/-
16 "	42 "	130/-
18 "	48 "	140/-

Carriage Forward.

Horticultural and Estate Appliances

RICHARD MELHUIH LIMITED, LONDON, E.C.

AUTOMATIC TACKING MACHINE

No. 1457W.

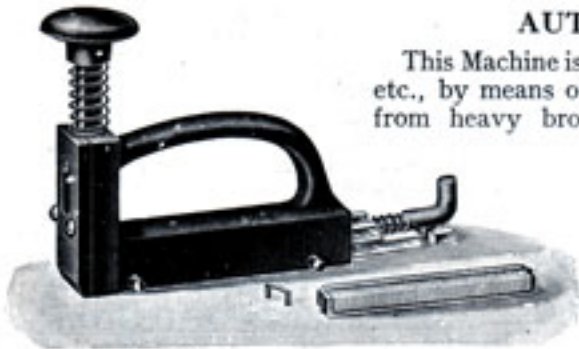

This Machine is constructed for fastening labels on to wooden cases, boxes, barrels, etc., by means of wire staples, instead of ordinary tacks. The staples are made from heavy broad flat wire, and being specially pointed will penetrate the toughest wood without buckling.

This Tacker works independent staples, not joined together in strip form.

It is extremely easy to operate, the pressure of the hand being sufficient to insert the staples.

The feeding device is thoroughly reliable, and the method of re-filling very simple.

The Machine holds 72 staples. It is always ready for use.

It holds the label more securely than ordinary tacks. Labels are fastened more quickly. There is no waste of staples.

Price 30/- each. Staples 1/6 per 1,000.

SINGLE STROKE STAPLE PRESS

This useful article is extensively used for binding documents and papers and for fastening patterns and samples of cloth, leather, calico, etc.

Price 12/6 each.
Wire Staples 1/- per 1,000.

No. 1459W.









STRONG LEVER PRESS

This is specially constructed to meet the requirements of the soft goods trade generally. Invaluable for making up patterns of woollens, silks, dress goods, etc. The Machine will take all the sizes of wire staples as illustrated below.

Price of Machine 36/- each.



No. 1458W.

No. 1	No. 2	No. 3	No. 3a	No. 4	No. 5	No. 6
$\frac{3}{8}$ -in.	$\frac{1}{2}$ -in.	$\frac{5}{8}$ -in.	$\frac{1}{2}$ -in.	$\frac{3}{4}$ -in.	$\frac{3}{4}$ -in.	1-in.
						
1/-	1/-	1/-	1/8	1/10	2/-	2/2
Price of Staples per 1,000.						2/2

SELF-FEEDING STAPLE PRESS

No. 1460W.

This Machine is constructed with a receptacle to hold 85 wire staples, which feed automatically to the inserting mechanism. It will be found most useful for binding together small books, vouchers, invoices, documents, etc. It will work Nos. 1, 2, and 3 Staples as shown above.

Price 40/- each.

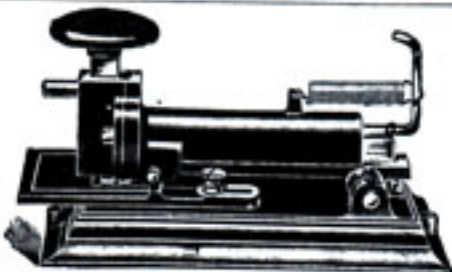

AUTOMATIC TACKING MACHINE

No. 1461W.

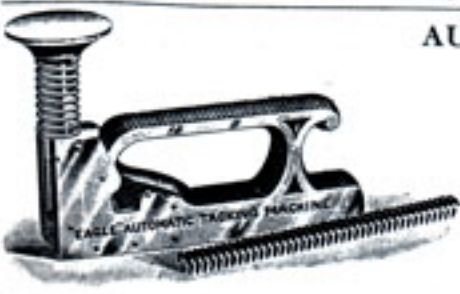

A real labour-saving device.

The staples are made from specially rolled steel plate, and, being pointed, will penetrate the toughest wood without buckling.

The Machine is self-feeding, holds 40 staples, which feed forward automatically, so that it is always ready for immediate use.

Price 10/6 each.
Staples 1/6 per 1,000.

Electric and Wireless Engineers

TOOL AND MACHINE MERCHANTS

HAND PUNCHING OR EYELETING MACHINES

No. 1462w.



Price, fitted with one set Cast Steel Dies, 15/- each.
Extra Dies, 5/- per set.

No. 1463w.

This is a favourite Machine for small work, 20,000 having been sold.



Price, fitted with one set Cast Steel Dies, 25/- each.
Extra Dies, 5/- per set

POWERFUL TREADLE PUNCHING OR EYELETING MACHINE

No. 1464w.

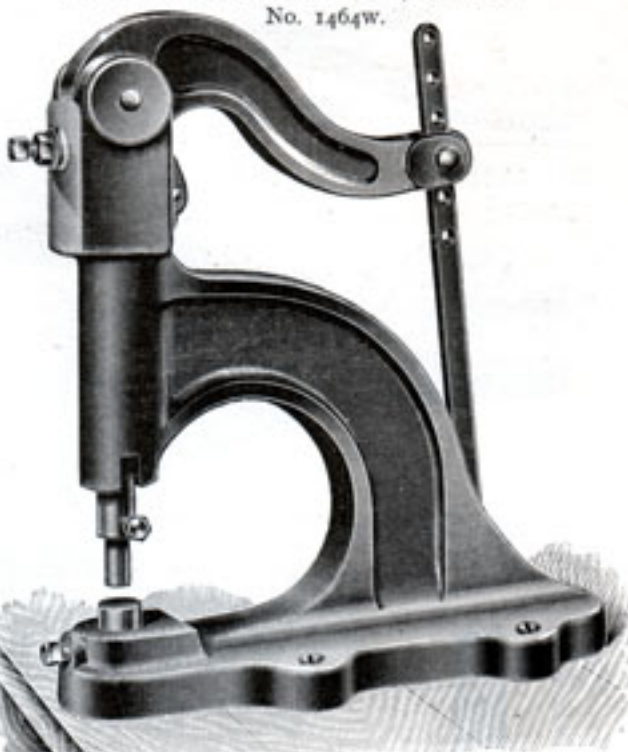

Suitable for punching and closing Sail Eyelets from 1 to 1 1/2 in. on face.
Price, fitted with one set of Dies ... 77/6 each.
Tools for other classes of work can also be fitted to this Machine.
Extra Closing Dies, 18/-; Punching Dies, 15/- per set.

TREADLE PUNCHING OR EYELETING MACHINES

No. 1465w.



No. 1. Light Treadle Machine.
Price, fitted with one set of Dies, 45/-
Extra Dies ... 4/6 per set.

No. 2. Heavy Design. Suitable for closing and punching Sail Eyelets, up to 1 in. on face.
Price, fitted with one set of Dies, 57/6

No. 3. 8 in. gap. Suitable for Show Card work, etc., where deep space is required.
Price, fitted with one set of Dies, 61/-
Extra Dies ... 5/- per set.

No. 1466w.



This Machine is most suitable for Hat and Cap work, Boot and Stationery Trades, where space is limited.
Price, without Dies ... 52/6 each.
Dies quoted for on receipt of particulars of work.

This Machine is extensively used in the Boot, Corset, Printing, Stationery, and Label Trades, also by all large consumers of eyelets who require their eyeleting done expeditiously.
Speed about 5,000 an hour.
Price 190/- each. If supplied with Iron Stand, 55/- extra.
Prices of extra Dies on application.

IMPROVED AUTOMATIC SELF-FEEDING TREADLE EYELETING MACHINE

No. 1467w.

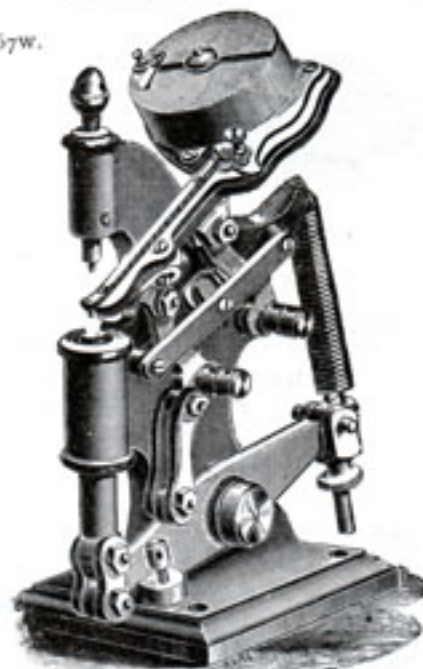

Special Dies and Punches to suit customers' requirements can be fitted to the above Machines.

Bronze Medal 1884—Gold Medal 1890



PLIERS FOR PRESS BUTTON WORK

No. 1468W.

Price, complete with 2 pairs of Punches and Dies, 8/6.
Size of buttons, Nos. 2-7, see below.

No. 1469W

We supply, in addition to the Pliers opposite, a **HANDY PUNCH SET**, consisting of Bed and 2 Punches, taking buttons Nos. 3-6. Price 3/9 per set.

COMBINED EYELET PUNCH AND CLOSER

No. 1470W.

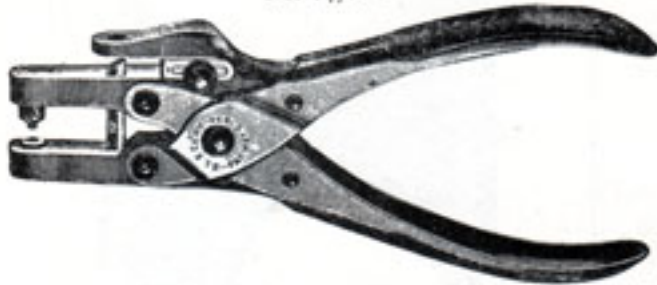

A most useful Tool and nicely nickel-plated. Length, 6½ in. Price 12/6 each. Eyelets in boxes of 250.

No. ...	1	2	3	4
Price...	1/-	1/2	1/6	1/8 per box.

SAIL EYELET BEDS AND PUNCHES

No. 1473W.



No.	Size of Hole in Eyelet.	Price per pair.
1	3/8 in.	4/6
2	1/2 "	4/6
3	5/8 "	4/6
4	3/4 "	4/6
5	7/8 "	5/-
7	1 "	6/-
9	1 1/8 "	7/-
10	1 1/4 "	7/-

EYELETS AND RINGS

No. 1474W.

No. ...	1	2	3	4	5	7	9	10
Price ...	1/9	2/4	2/8	3/2	4/-	6/3	8/-	11/- per gross.

HAND MACHINE FOR PUNCHING SMALL HOLES IN METAL

No. 1475W

Depth of Gap, 2½ in.

Price of Machine complete, £1 : 10 : 0 Extra Punch and Die, 7/6

UNIVERSAL PUNCH

No. 1476W.



These Punches are for punching holes in soft metals, cardboard, rubber, cloth, etc. Length, 7 in. Price 10/- each.
Sizes supplied, 1/8, 1/4, 3/8, and 1/2 in.
Extra Punch, 3/-; extra Die, 3/- each.

PRESS BUTTONS

No. 1471W.

In Gilt or Silver.

Size.	Price, per gross.
2	5/-
3	6/-
4	6/6
5	7/-
6	7/6
7	10/-

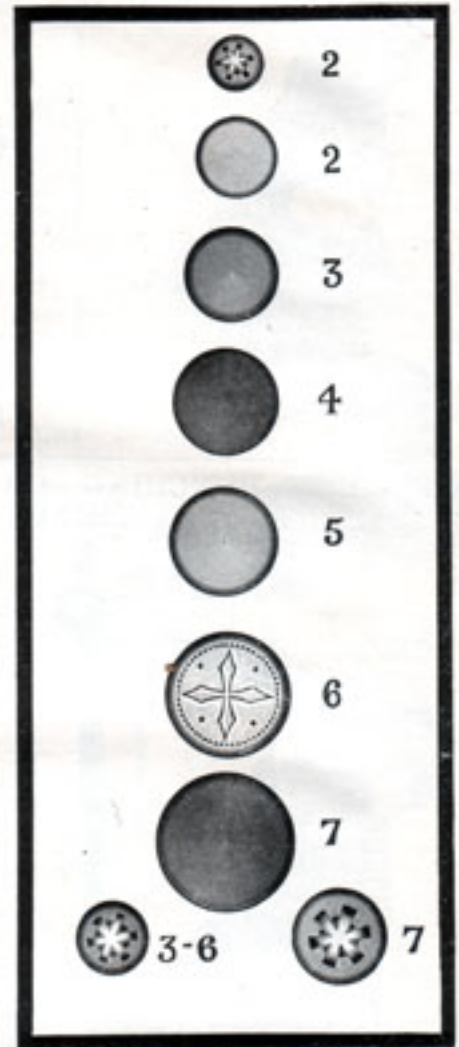

No. 1472W.

Coloured.

Size.	Price, per gross.
2	5/6
3	6/6
4	7/-
5	8/-
6	8/6
7	12/6

Not less than 1/2 gross each supplied of any size



TOOL AND MACHINE MERCHANTS

PANEL PLANER AND THICKNESSING MACHINE

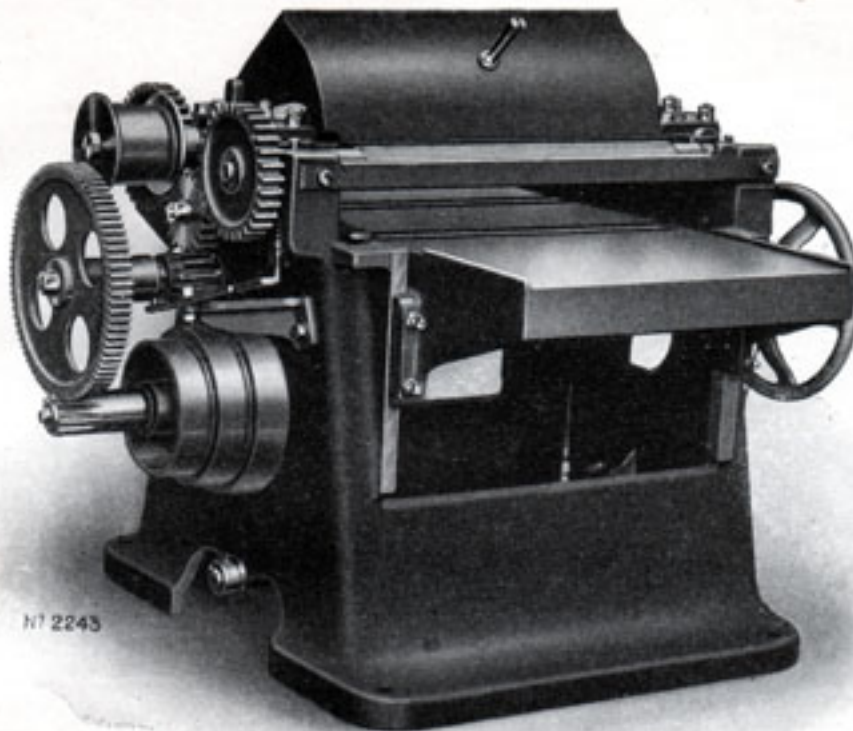

No. 1477W.

N7 2243

A SUCCESSFUL PLANER AND THICKNESSER intended for the use of the joiner, builder, and shipbuilder, as well as for the maker of heavy engineering patterns, this Machine has demonstrated its usefulness and efficiency, and established its position as one of the MOST UP-TO-DATE Planers on the market.

HIGH CUTTING SPEED AND FEED RATES can only be attained by effective drives, and in the case of wide machines the two-belt drive possesses advantages over its single-drive rival. The driving is more uniform, the strain on the spindle is diminished, expense in belt upkeep is reduced, heavier cuts and higher feed rates are possible, and in emergencies one belt may run the machine whilst the second belt is overhauled.

The MAIN FRAME is of box section, exceedingly strong and rigid, and of sufficient weight to prevent the high rotary speed of the cutters inducing vibrations, which would prejudicially affect the finished surface. The vertical guides for the table being formed on the four corners of the main frame, lateral vibration of the table is impossible. The CUTTER BLOCK is arranged to give a shearing cut.

BALL BEARINGS may be fitted and are recommended when economy of power is desired, but the Machine is also supplied fitted with long gun-metal ring-oiling bearings, and swivel ring-oiling bearings are fitted to the countershaft.

The TABLE is supported on two screws with ball thrust washers, and is operated by a hand wheel on the side of the frame, the lifting of the table being easily performed. Two friction rollers are fitted in the table.

The FEED MOTION is operated by MACHINE-CUT GEARING. Three rates of feed are provided, and the feed can be instantly started and stopped.

PRESSURE BARS of an effective type are fitted between the feed rollers, and suitable guards are fitted to various parts of the Machine.

EACH MACHINE is complete with countershaft, one pair of plane irons, dovetail cutter bolts, and spanners.

SIZES AND PARTICULARS

Size.	Countershaft Pulleys.			Power required.	Approximate Net Weight.	Prices.	
	Diameter.	Width.	Speed.			Ring-oiling Bearings.	Ball Bearings.
16 x 9 in.	10 in.	5 in.	r.p.m. 800	4 b.h.p.	18 cwt.	£70 : 0 : 0	£78 : 0 : 0
20 x 9 ..	10 ..	5 ..	800	5 ..	20 ..	£79 : 0 : 0	£88 : 0 : 0
24 x 9 ..	12 ..	6 ..	800	6 ..	24 ..	£88 : 0 : 0	£97 : 0 : 0
30 x 9 ..	12 ..	6 ..	800	8 ..	27 ..	£110 : 0 : 0	£120 : 0 : 0

Extras for any size Double Belt Drive, £7 : 0 : 0.

If prepared for working Mouldings, £3 : 10 : 0.

Carriage Forward.

Builders' and Furnishing Ironmongery

PRINTED IN GREAT BRITAIN BY
HAZELL, WATSON AND VINEY, LD.,
LONDON AND AVLESBURY.

NEW – NOVEL – EFFICIENT

PLANE IRON & CHISEL GRINDING ATTACHMENT

‘The Bevelmaster’

(PATENTED)
(Can be fitted to any mounted grindstone)

For grinding all Plane Irons, Chisels, Gouges, Vee tools, etc.

An entirely original approach to an old problem. Preserves the bevel, square and true and saves much time and trouble.

INVALUABLE to TECHNICAL INSTRUCTORS & AMATEURS

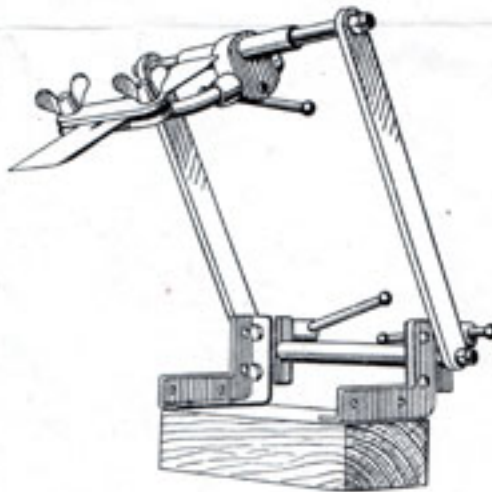

*With Projector
Gauge for
bevels and angles.*

ZINC PLATED

PRICE
£7 7s. 0d.

Carriage paid

TO BE OBTAINED ONLY FROM

RICHARD MELHUISH,
(LONDON) LTD.

184/6 GOSWELL ROAD, LONDON, E.C.1.

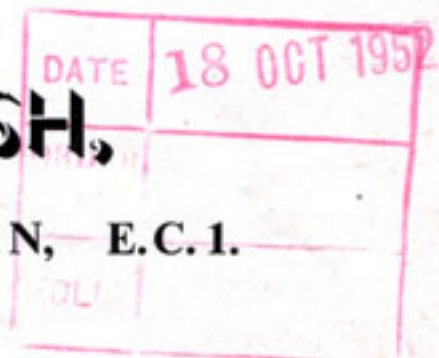

IRWIN SETS of BITS.

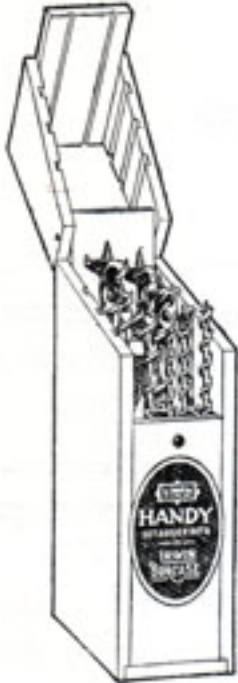

IRWIN SETS are packed in three different styles of containers: the upright wooden case, called the Borcase, the canvas roll, Borkit, and the old style wooden chest, Borchest. These keep an assortment together in the order of their sizes, prevent rust or injury from contact with other tools, and form a convenient packet to carry.

BORCASE

The Borcase is a set box of Irwin design made of matched hardwood, glued, pressed and nailed. It has an eyelet and pin hinge and a positive lock. It is finished with two coats of water-proof shellac.

The inside divisions make a separate compartment for each bit.



BORKIT

The Borkit is made of eight-ounce double-filled slate-colored duck, lined with non-tarnishable flannel. It is bound with braid, overcast with thread and fastened with a webbing strap that fits into a nickel-plated buckle. There is a satin label on the flap.



BORCHEST

The Borchest is made of hard wood, oil-finished and dovetailed at the corners. The hinges and catches are of brass. The bits lay in grooved tills. The larger Borchests have two tills, one of which is hinged and swings out.

For particulars of contents of sets and list prices see over.

THE IRWIN BIT.



The IRWIN SOLID CENTER BIT owes its world-wide popularity to its superior boring quality. This is due to the perfect development of the solid center principle in Irwin Bits, to excellent material and accuracy of workmanship made possible only by nearly 40 years of carefully planned and organised bit making.

Irwin Bits are not twisted or milled out of round rods. They are pounded out, of special analysis steel, under power hammers. The hammering of the steel at the proper temperature densifies it, and increases its wearing qualities. This is part of the Irwin process which includes patented methods for producing uniform quality. The machines and dies with which Irwin Bits are forged are of Irwin design and are protected by patents.

More Irwin Bits are in use to-day than those of any other make.

Irwin Auger Bits are stocked in the following sizes:

3	4	5	6	7	8	9	10	11	12	13	Sixteenths
18/9	16/8	16/8	16/8	18/9	20/10	22/11	25/-	29/2	29/2	33/4	List Price per doz.
14	15	16	17	18	19	20	21	22	23	24	Sixteenths
33/4	37/6	37/6	43/9	43/9	50/-	50/-	56/3	56/3	62/6	62/6	List Price per doz.

Irwin Bits are also put up in sets of convenient assortments, in hardwood boxes and canvas rolls, for description see overleaf.

The table below shows the sizes of bits in each assortment, also list prices for sets in Borcase or Borchest (hardwood box) and Borkit (canvas roll).

Name of Set	In Borcase Letter	In Borkit Letter	In Borchest Letter	Kind of Bits in Set	Total Bits	No. of Quarters in each Set	Sizes in 16ths of an Inch										Screw-driver Bit	List Price per Set				
							4	5	6	7	8	9	10	11	12	13		14	15	16	In Borcase or Borchest	In Borkit
Little Six	AA	AAR	AAM	Mainbor ...	6	11½	1	1	1	—	1	—	1	—	1	—	—	—	—	—	16/3	14/7
Home ...	BB	BBR	BBM	..	6	14	1	—	1	—	1	—	1	—	1	—	—	1	—	—	17/11	15/10
Handy ...	A	AR	AM	..	10	20½	1	1	1	1	1	—	1	—	1	—	1	1	1	1	25/10	24/2
Carpenters	D	DR	DM	..	13	32½	1	1	1	1	1	1	1	1	1	1	1	1	1	1	34/2	32/6
Cabinet ...	DS	DSR	DSM	Smoothbor	13	32½	1	1	1	1	1	1	1	1	1	1	1	1	1	1	37/6	35/5
—	—	CR	CM	Mainbor ...	11	25½	1	1	1	1	1	1	1	1	1	—	1	—	1	—	29/2	28/4